



COVER SHEET

Proposal Submitted By:

Contractor's Name

Contractor's Address

City

State

Zip Code

STATE OF ILLINOIS

Local Public Agency

County

Section Number

Route(s) (Street/Road Name)

Type of Funds

Proposal Only Proposal and Plans Proposal only, plans are separate

Submitted/Approved

For Local Public Agency:

For a County and Road District Project

Submitted/Approved

Highway Commissioner Signature

Date

Submitted/Approved

County Engineer/Superintendent of Highways

Date

For a Municipal Project

Submitted/Approved/Passed

Signature

Date

Official Title

Department of Transportation

Released for bid based on limited review

Regional Engineer Signature

Date

**County Engineer
on behalf of IDOT pursuant to
Agreement of Understanding
Dated August 7, 2012**

Note: All proposal documents, including Proposal Guaranty Checks or Proposal Bid Bonds, should be stapled together to prevent loss when bids are processed.

Local Public Agency	County	Section Number	Route(s) (Street/Road Name)
County of DuPage	DuPage	22-PVMTC-17-GM	2022 Pavement Maintenance - North Region

NOTICE TO BIDDERS

Sealed proposals for the project described below will be received at the office of the DuPage County Division of Transportation

<u>421 N. County Farm Road, 2nd Floor, Wheaton, IL 60187</u>	Name of Office	until	<u>2:00 PM</u>	on	<u>03-29-22</u>
Address			Time		Date

Sealed proposals will be opened and read publicly at the office of the DuPage County Division of Transportation

<u>421 N. County Farm Road, 2nd Floor, Wheaton, IL 60187</u>	Name of Office	at	<u>2:00 PM</u>	on	<u>03-29-22</u>
Address			Time		Date

DESCRIPTION OF WORK

Location	Project Length
Army Trail Road, Geneva Road, Powis Road.	6.6 Miles

Proposed Improvement

HMA removal and replacement, pavement patching, curb and gutter removal and replacement, sidewalk removal and replacement, pavement markings, and all necessary appurtenances needed to complete the work.

1. Plans and proposal forms will be available in the office of

on line at <http://www.dupageco.org/dot/doingbusiness>
or by contacting the Division of Transportation at (630) 407-6900.

2. **Prequalification**
If checked, the 2 apparent as read low bidders must file within 24 hours after the letting an "Affidavit of Availability" (Form BC 57) in triplicate, showing all uncompleted contracts awarded to them and all low bids pending award for Federal, State, County, Municipal and private work. One original shall be filed with the Awarding Authority and two originals with the IDOT District Office.
3. The Awarding Authority reserves the right to waive technicalities and to reject any or all proposals as provided in BLRS Special Provision for Bidding Requirements and Conditions for Contract Proposals.
4. The following Forms shall be returned by the bidder to the Awarding Authority:
 - a. Local Public Agency Formal Contract Proposal (BLR 12200)
 - b. Schedule of Prices (DuPage County version of BLR 12201)
 - c. Proposal Bid Bond (BLR 12230)
 - d. **DuPage County Apprenticeship or Training Program Certification (all Apprenticeship/Training Registration Number(s) and/or Certificate(s) need to be included with this form)**
 - e. Affidavit of Illinois Business Office (BLR 12326) (do not use for project with Federal funds)
 - f. **DuPage County - Required Vendor Ethics Disclosure Statement**
 - g. **IRS Form W-9: Request for Taxpayer Identification Number and Certification**
 - h. **Three (3) References Form**
5. The quantities appearing in the bid schedule are approximate and are prepared for the comparison of bids. Payment to the Contractor will be made only for the actual quantities of work performed and accepted or materials furnished according to the contract. The scheduled quantities of work to be done and materials to be furnished may be increased, decreased or omitted as hereinafter provided.
6. Submission of a bid shall be conclusive assurance and warranty the bidder has examined the plans and understands all requirements for the performance of work. The bidder will be responsible for all errors in the proposal resulting from failure or neglect to conduct an in depth examination. The Awarding Authority will, in no case, be responsible for any costs, expenses, losses or changes in anticipated profits resulting from such failure or neglect of the bidder.
7. The bidder shall take no advantage of any error or omission in the proposal and advertised contract.
8. If a special envelope is supplied by the Awarding Authority, each proposal should be submitted in that envelope furnished by the Awarding Agency and the blank spaces on the envelope shall be filled in correctly to clearly indicate its contents. When an envelope other than the special one furnished by the Awarding Authority is used, it shall be marked to clearly indicate its contents. When sent by mail, the sealed proposal shall be addressed to the Awarding Authority at the address and in care of the official in whose office the bids are to be received. All proposals shall be filed prior to the time and at the place specified in the Notice to Bidders. Proposals received after the time specified will be returned to the bidder unopened.
9. Permission will be given to a bidder to withdraw a proposal if the bidder makes the request in writing or in person before the time for opening proposals.

Local Public Agency	County	Section Number	Route(s) (Street/Road Name)
County of DuPage	DuPage	22-PVMT-17-GM	2022 Pavement Maintenance - North Region

PROPOSAL

1. Proposal of _____ Contractor's Name _____
 _____ Contractor's Address _____
2. The plans for the proposed work are those prepared by County of DuPage
 and approved by the Department of Transportation on _____.
3. The specifications referred to herein are those prepared by the Department of Transportation and designated as "Standard Specifications for Road and Bridge Construction" and the " Supplemental Specifications and Recurring Special Provisions" thereto, adopted and in effect on the date of invitation for bids.
4. The undersigned agrees to accept, as part of the contract, the applicable Special Provisions indicated on the "Check Sheet for Recurring Special Provisions" contained in this proposal.
5. The undersigned agrees to complete the work within _____ working days or by 9/23/2022 unless additional time is granted in accordance with the specifications.
6. The successful bidder at the time of execution of the contract will be required to deposit a contract bond for the full amount of the award. When a contract bond is not required, the proposal guaranty check will be held in lieu thereof. If this proposal is accepted and the undersigned fails to execute a contract and contract bond as required, it is hereby agreed that the Bid Bond of check shall be forfeited to the Awarding Authority.
7. Each pay item should have a unit price and a total price. If no total price is shown or if there is a discrepancy between the products of the unit price multiplied by the quantity, the unit price shall govern. If a unit price is omitted, the total price will be divided by the quantity in order to establish a unit price. A bid may be declared unacceptable if neither a unit price nor a total price is shown.
8. The undersigned submits herewith the schedule of prices on BLR 12201 covering the work to be performed under this contract.
9. The undersigned further agrees that if awarded the contract for the sections contained in the combinations on BLR 12201, the work shall be in accordance with the requirements of each individual proposal for the multiple bid specified in the Schedule for Multiple Bids below.
10. A proposal guaranty in the proper amount, as specified in BLRS Special Provision for Bidding Requirements and Conditions for Contract Proposals, will be required. Bid Bonds will be allowed as a proposal guaranty. Accompanying this proposal is either a bid bond, if allowed, on Department form BLR 12230 or a proposal guaranty check, complying with the specifications, made payable to: County Treasurer of DuPage.
 The amount of the check is _____ (_____).

Attach Cashier's Check or Certified Check Here

In the event that one proposal guaranty check is intended to cover two or more bid proposals, the amount must be equal to the sum of the proposal guaranties which would be required for each individual bid proposal. If the proposal guaranty check is placed in another bid proposal, state below where it may be found.

The proposal guaranty check will be found in the bid proposal for: Section Number _____ .

Local Public Agency	County	Section Number	Route(s) (Street/Road Name)
County of DuPage	DuPage	22-PVMTC-17-GM	2022 Pavement Maintenance - North Region

CONTRACTOR CERTIFICATIONS

The certifications hereinafter made by the bidder are each a material representation of fact upon which reliance is placed should the Department enter into the contract with the bidder.

- Debt Delinquency.** The bidder or contractor or subcontractor, respectively, certifies that it is not delinquent in the payment of any tax administered by the Department of Revenue unless the individual or other entity is contesting, in accordance with the procedure established by the appropriate Revenue Act, its liability for the tax or the amount of the tax. Making a false statement voids the contract and allows the Department to recover all amounts paid to the individual or entity under the contract in a civil action.
- Bid-Rigging or Bid Rotating.** The bidder or contractor or subcontractor, respectively, certifies that it is not barred from contracting with the Department by reason of a violation of either 720 ILCS 5/33E-3 or 720 ILCS 5/33E-4.

A violation of section 33E-3 would be represented by a conviction of the crime of bid-rigging which, in addition to Class 3 felony sentencing, provides that any person convicted of this offense, or any similar offense of any state or the United States which contains the same elements as this offense shall be barred for 5 years from the date of conviction from contracting with any unit of State or local government. No corporation shall be barred from contracting with any unit of State or local government as a result of a conviction under this Section of any employee or agent of such corporation if the employee so convicted is no longer employed by the corporation: (1) it has been finally adjudicated not guilty or (2) if it demonstrates to the governmental entity with which it seeks to contract that entity finds that the commission of the offense was neither authorized, requested, commanded, nor performed by a director, officer or a high managerial agent on behalf of the corporation.

A violation of Section 33E-4 would be represented by a conviction of the crime of bid-rotating which, in addition to Class 2 felony sentencing, provides that any person convicted of this offense or any similar offense of any state or the United States which contains the same elements as this offense shall be permanently barred from contracting with any unit of State of Local government. No corporation shall be barred from contracting with any unit of State or Local government as a result of a conviction under this Section of any employee or agent of such corporation if the employee so convicted is no longer employed by the corporation and: (1) it has been finally adjudicated not guilty or (2) if it demonstrates to the governmental entity with which it seeks to contract and that entity finds that the commission of the offense was neither authorized, requested, commanded, nor performed by a director, officer or a high managerial agent on behalf of the corporation.

- Bribery.** The bidder or contractor or subcontractor, respectively, certifies that, it has not been convicted of bribery or attempting to bribe an officer or employee of the State of Illinois or any unit of local government, nor has the firm made an admission of guilt of such conduct which is a matter or record, nor has an official, agent, or employee of the firm committed bribery or attempted bribery on behalf of the firm and pursuant to the direction or authorization of a responsible official of the firm.
- Interim Suspension or Suspension.** The bidder or contractor or subcontractor, respectively, certifies that it is not currently under a suspension as defined in Subpart I of Title 44 Subtitle A Chapter III Part 6 of the Illinois Administrative code. Furthermore, if suspended prior to completion of this work, the contract or contracts executed for the completion of this work may be canceled.

Local Public Agency

County

Section Number

Route(s) (Street/Road Name)

County of DuPage

DuPage

22-PVMTC-17-GM

2022 Pavement Maintenance - North Region

SIGNATURES

(If an individual)

Signature of Bidder

Date

--	--

Business Address

--

City

State

Zip Code

--	--	--

(If a partnership)

Firm Name

--

Signature

Date

--	--

Title

--

Business Address

--

City

State

Zip Code

--	--	--

Insert the Names and Addresses of all Partners

--

(If a corporation)

Corporate Name

--

Signature

Date

--	--

Title

--

Business Address

--

City

State

Zip Code

--	--	--

Insert Names of Officers

President

--

Attest:

Secretary

Secretary

Treasurer

RETURN WITH BID



SCHEDULE OF PRICES

Contractor's Name:

Local Public Agency: County of DuPage

County: DuPage

Section: 22-PVMTC-17-GM

Route: 2022 Pav. Maint. - North

Schedule for Multiple Bids

Combination Letter	Sections included in Combinations	Total

Schedule for Single Bid

(For complete information covering these items, see plans and specifications)

Item No.	Items	Unit	Quantity	Unit Price	Total
1	SEED BED PREPARATION	SQ YD	2487		
2	SEEDING, CLASS 2A	ACRE	0.51		
3	EROSION CONTROL BLANKET	SQYD	2487		
4	REMOVAL AND DISPOSAL OF UNSUITABLE MATERIAL	CU YD	50		
5	AGGREGATE WEDGE SHOULDER, TYPE B	TON	200		
6	BITUMINOUS MATERIALS (TACK COAT)	POUND	148052		
7	LONGITUDINAL JOINT SEALANT	FOOT	107053		
8	MIXTURE FOR CRACKS, JOINTS AND FLANGWAYS	TON	213		
9	POLYMERIZED LEVELING BINDER MACHINE METHOD IL-4.75 N50	TON	8701		
10	HMA BINDER COURSE, IL-19.0, N90	TON	1364		
11	HMA SURFACE COURSE, MIX "D", N70	TON	1619		
12	POLYMERIZED HMA SURFACE COURSE, MIX "E", N70	TON	19474		
13	PORTLAND CEMENT CONCRETE SIDEWALK REMOVAL	SQ FT	9017		
14	PORTLAND CEMENT CONCRETE SIDEWALK 5 INCH	SQ FT	8998		

RETURN WITH BID

Item No.	Items	Unit	Quantity	Unit Price	Total
15	DETECTABLE WARNINGS	SQ FT	1083		
16	HMA SURFACE REMOVAL 2.25"	SQ YD	18776		
17	HMA SURFACE REMOVAL 2.5"	SQ YD	193532		
18	HMA SURFACE REMOVAL 4"	SQ YD	10540		
19	HMA SURFACE REMOVAL - BUTT JOINT	SQ YD	1205		
20	COMBINATION CONCRETE CURB AND GUTTER REMOVAL AND REPLACEMENT	FOOT	9935		
21	TEMPORARY STONE	TON	60		
22	CLASS D PATCH, TYPE I , 10"	SQ YD	123		
23	CLASS D PATCH, TYPE II, 10"	SQ YD	367		
24	CLASS D PATCH, TYPE III, 10"	SQ YD	367		
25	CLASS D PATCH, TYPE IV, 10"	SQ YD	123		
26	CLASS D PATCH, TYPE I , 12"	SQ YD	66		
27	CLASS D PATCH, TYPE II, 12"	SQ YD	198		
28	CLASS D PATCH, TYPE III, 12"	SQ YD	198		
29	CLASS D PATCH, TYPE IV, 12"	SQ YD	66		
30	CLASS D PATCH, TYPE I , 13"	SQ YD	78		
31	CLASS D PATCH, TYPE II, 13"	SQ YD	233		
32	CLASS D PATCH, TYPE III, 13"	SQ YD	233		
33	CLASS D PATCH, TYPE IV, 13"	SQ YD	78		
34	DRAINAGE STRUCTURE TO BE RECONSTRUCTED	EACH	5		
35	DRAINAGE STRUCTURE TO BE REMOVED	EACH	12		
36	INLET TY. A	EACH	12		
37	FRAME AND LIDS, TYPE 1	EACH	32		
38	FRAMES AND GRATES, TYPE 23	EACH	8		

RETURN WITH BID

Item No.	Items	Unit	Quantity	Unit Price	Total
39	DRAINAGE STRUCTURE TO BE ADJUSTED	EACH	64		
40	DRAINAGE STRUCTURE CLEAN AND PATCH	EACH	29		
41	FRAMES AND LIDS TO BE ADJUSTED, SPECIAL	EACH	65		
42	SHORT TERM PAVEMENT MARKING	FOOT	19847		
43	THERMOPLASTIC PAVEMENT MARKING - LETTERS AND SYMBOLS	SQ FT	4301		
44	THERMOPLASTIC PAVEMENT MARKING - LINE 4"	FOOT	89624		
45	THERMOPLASTIC PAVEMENT MARKING - LINE 6"	FOOT	12309		
46	THERMOPLASTIC PAVEMENT MARKING - LINE 8"	FOOT	350		
47	THERMOPLASTIC PAVEMENT MARKING - LINE 12"	FOOT	5687		
48	THERMOPLASTIC PAVEMENT MARKING - LINE 24"	FOOT	1750		
49	MODIFIED URETHANE PAVEMENT MARKING - RAISED MEDIAN	SQ FT	896		
50	TEMPORARY PAINT PAVEMENT MARKING - LETTERS & SYMBOLS	SQ FT	3226		
51	TEMPORARY PAINT PAVEMENT MARKING - LINE 4"	FOOT	341704		
52	TEMPORARY PAINT PAVEMENT MARKING - LINE 24"	FOOT	7000		
53	RAISED REFLECTIVE PAVEMENT MARKER REMOVAL	EACH	38		
54	RECESSED REFLECTIVE PAVEMENT MARKER	EACH	2985		
55	DETECTOR LOOP REPLACEMENT	FOOT	2629		
56	MAINTENANCE OF EXISTING TRAFFIC SIGNAL INSTALLATION	EACH	9		
57	HANDHOLE TO BE ADJUSTED	EACH	2		
58	RELOCATE EXISTING PEDESTRIAN PUSH BUTTON	EACH	21		
59	REMOVE EXISTING PEDESTRIAN PUSH BUTTON	EACH	2		
60	REMOVE EXISTING PEDESTRIAN SIGNAL HEAD	EACH	2		
61	MODIFY EXISTING CONTROLLER AND CABINET	EACH	1		
62	TRAFFIC CONTROL & PROTECTION	L SUM	1		

RETURN WITH BID

Item No.	Items	Unit	Quantity	Unit Price	Total
63	CHANGEABLE MESSAGE SIGN	CAL DAY	154		
64	RAILROAD PROTECTIVE LIABILITY INSURANCE	L SUM	1		
65	RAILROAD FLAGGING	DOLLAR	15000	1.00	15,000.00
66	EMERGENCY POTHOLE PATCHING	DOLLAR	20000	1.00	20,000.00
Bidder's proposal for making entire improvements					

1. Each pay item should have a unit price and a total price.
2. If no total price is shown or if there is a discrepancy between the product of the unit price multiplied by the quantity, the unit price shall govern.
3. If a unit price is omitted, the total price will be divided by the quantity in order to establish a unit price.
4. A bid may be declared unacceptable if neither a unit price or total price is shown.



Local Public Agency County of DuPage	County DuPage	Section Number 22-PVMTC-17-GM
---	------------------	----------------------------------

WE, _____ as PRINCIPAL, and

_____ as SURETY, are held jointly, severally and firmly bound unto the above Local Public Agency (hereafter referred to as "LPA") in the penal sum of 5% of the total bid price, or for the amount specified in the proposal documents in effect on the date of invitation for bids, whichever is the lesser sum. We bind ourselves, our heirs, executors, administrators, successors, and assigns, jointly pay to the LPA this sum under the conditions of this instrument.

WHEREAS THE CONDITION OF THE FOREGOING OBLIGATION IS SUCH that, the said PRINCIPAL is submitting a written proposal to the LPA acting through its awarding authority for the construction of the work designated as the above section.

THEREFORE if the proposal is accepted and a contract awarded to the PRINCIPAL by the LPA for the above designated section and the PRINCIPAL shall within fifteen (15) days after award enter into a formal contract, furnish surety guaranteeing the faithful performance of the work, and furnish evidence of the required insurance coverage, all as provided in the "Standard Specifications for Road and Bridge Construction" and applicable Supplemental Specifications, then this obligation shall become void; otherwise it shall remain in full force and effect.

IN THE EVENT the LPA determines the PRINCIPAL has failed to enter into a formal contract in compliance with any requirements set forth in the preceding paragraph, then the LPA acting through its awarding authority shall immediately be entitled to recover the full penal sum set out above, together with all court costs, all attorney fees, and any other expense of recovery.

IN TESTIMONY WHEREOF, the said PRINCIPAL and the said SURETY have caused this instrument to be signed by their respective officers this _____ of _____ Day Month and Year

Principal

Company Name
[]

Signature [] Date []

By: []

Title
[]

Company Name
[]

Signature [] Date []

By: []

Title
[]

(If Principal is a joint venture of two or more contractors, the company names, and authorized signatures of each contractor must be affixed.)

Surety

Name of Surety
[]

Signature of Attorney-in-Fact [] Date []

By: []

STATE OF IL
COUNTY OF

I _____, a Notary Public in and for said county do hereby certify that

(Insert names of individuals signing on behalf of PRINCIPAL & SURETY)

who are each personally known to me to be the same persons whose names are subscribed to the foregoing instrument on behalf of PRINCIPAL and SURETY, appeared before me this day in person and acknowledged respectively, that they signed and delivered said instruments as their free and voluntary act for the uses and purposes therein set forth.

Given under my hand and notarial seal this [] day of _____ Month and Year

(SEAL)

Notary Public Signature
[]

Date commission expires _____

Local Public Agency

County

Section Number

County of DuPage

DuPage

22-PVMTC-17-GM

ELECTRONIC BID BOND

Electronic bid bond is allowed (box must be checked by LPA if electronic bid bond is allowed)

The Principal may submit an electronic bid bond, in lieu of completing the above section of the Proposal Bid Bond Form. By providing an electronic bid bond ID code and signing below, the Principal is ensuring the identified electronic bid bond has been executed and the Principal and Surety are firmly bound unto the LPA under the conditions of the bid bond as shown above. (If PRINCIPAL is a joint venture of two or more contractors, an electronic bid bond ID code, company/Bidder name title and date must be affixed for each contractor in the venture.)

Electronic Bid Bond ID Code

--	--	--	--	--	--	--	--	--	--	--	--	--	--	--	--	--	--	--	--	--

Company/Bidder Name

--

Signature

--

Date

--

Title

--



Apprenticeship and Training Program Certification

RETURN WITH BID

Local Public Agency	County	Street Name/Road Name	Section Number
County of DuPage	DuPage	Various	22-PVMT-17-GM

All contractors are required to complete the following certification

- For this contract proposal or for all bidding groups in this deliver and install proposal.
- For the following deliver and install bidding groups in this material proposal.

The County of DuPage policy, adopted in accordance with DuPage County, Illinois County Code, requires this contract to be awarded to the lowest responsive and responsible bidder. The award decision is subject to approval by the Department. In addition to all other responsibility factors, this contract or deliver and install proposal requires all bidders and all bidder's subcontractors to disclose participation in apprenticeship or training programs that are (1) approved by and registered with the United States Department of Labor's Bureau of Apprenticeship and Training, and (2) applicable to the work of the above indicated proposals or groups. Therefore, all bidders are required to complete the following certification:

1. Except as provided in paragraph 4 below, the undersigned bidder certifies that it is a participant, either as an individual or as part of a group program, in an approved apprenticeship or training program applicable to each type of work or craft that the bidder will perform with its own employees.
2. The undersigned bidder further certifies, for work to be performed by subcontract, that each of its subcontractors either (A) is, at the time of such bid, participating in an approved, applicable apprenticeship or training program; or (B) will, prior to commencement of performance of work pursuant to this contract, establish participation in an approved apprenticeship or training program applicable to the work of the subcontract.
3. The undersigned bidder, by inclusion in the list in the space below, certifies the official name of each program sponsor holding the Certificate of Registration for all of the types of work or crafts in which the bidder is a participant and that will be performed with the bidder's employees. Types of work or craft that will be subcontracted shall be included and listed as subcontract work.

4. Except for any work identified above, if any bidder or subcontractor shall perform all or part of the work of the contract or deliver and install proposal solely by individual owners, partners or members and not by employees to whom the payment of prevailing rates of wages would be required, check the following box, and identify the owner/operator workforces and positions of ownership.

The requirements of this certification and disclosure are a material part of the contract, and the contractor shall require this certification provision to be included in all approved subcontracts. The bidder is responsible for making a complete report and shall make certain that each type of work or craft job category that will be utilized on the project is accounted for and listed. The Department at any time before or afterward may require the production of a copy of each applicable Certificate of Registration issued by the United States Department of Labor evidencing such participation by the contractor and any or all of its subcontractors. In order to fulfill the participation requirement, it shall not be necessary that any applicable program sponsor be currently taking or that it will take applications for apprenticeship, training or employment during the performance of the work of this contract or deliver and install proposal.

Bidder	Signature	Date	
<div style="border: 1px solid black; height: 20px;"></div>	<div style="border: 1px solid black; height: 40px;"></div>	<div style="border: 1px solid black; height: 40px;"></div>	
Title			
<div style="border: 1px solid black; height: 20px;"></div>			
Address	City	State	Zip Code
<div style="border: 1px solid black; height: 20px;"></div>	<div style="border: 1px solid black; height: 20px;"></div>	<div style="border: 1px solid black; height: 20px;"></div>	<div style="border: 1px solid black; height: 20px;"></div>



Affidavit of Illinois Business Office



Local Public Agency	County	Street Name/Road Name	Section Number
County of DuPage	DuPage	Various	22-PVMTC-17-GM

I, _____ of _____, _____,
Name of Affiant City of Affiant State of Affiant

being first duly sworn upon oath, state as follows:

1. That I am the _____ of _____.
Officer or Position Bidder
2. That I have personal knowledge of the facts herein stated.
3. That, if selected under the proposal described above, _____, will maintain a business office in the
Bidder
 State of Illinois, which will be located in _____ County, Illinois.
County
4. That this business office will serve as the primary place of employment for any persons employed in the construction contemplated by this proposal.
5. That this Affidavit is given as a requirement of state law as provided in Section 30-22(8) of the Illinois Procurement Code.

Signature	Date
Print Name of Affiant	

Notary Public

State of IL

County _____

Signed (or subscribed or attested) before me on _____ by
(date)

_____, authorized agent(s) of
(name/s of person/s)

Bidder

Signature of Notary Public

(SEAL)

My commission expires _____



Bureau of Construction
2300 South Dirksen Parkway/Room 322
Springfield, IL 62764

Instructions: Complete this form by either typing or using black ink. "Authorization to Bid" will not be issued unless both sides of this form are completed in detail. Use additional forms as needed to list all work.

Part I. Work Under Contract

List below all work you have under contract as either a prime contractor or a subcontractor. It is required to include all pending low bids not yet awarded or rejected. In a joint venture, list only that portion of the work which is the responsibility of your company. The uncompleted dollar value is to be based upon the most recent engineer's or owners estimate, and must include work subcontracted to others. If no work is contracted, show NONE.

	1	2	3	4	Awards Pending	Accumulated Totals
Contract Number						
Contract With						
Estimated Completion Date						
Total Contract Price						
Uncompleted Dollar Value if Firm is the Prime Contractor						
Uncompleted Dollar Value if Firm is the Subcontractor						
Total Value of All Work						

Part II. Awards Pending and Uncompleted Work to be done with your own forces.

List below the uncompleted dollar value of work for each contract and awards pending to be completed with your own forces. All work subcontracted to others will be listed on the reverse of this form. In a joint venture, list only that portion of the work to be done by your company. If no work is contracted, show NONE.

Earthwork						
Portland Cement Concrete Paving						
HMA Plant Mix						
HMA Paving						
Clean & Seal Cracks/Joints						
Aggregate Bases, Surfaces						
Highway, R.R., Waterway Struc.						
Drainage						
Electrical						
Cover and Seal Coats						
Concrete Construction						
Landscaping						
Fencing						
Guardrail						
Painting						
Signing						
Cold Milling, Planning, Rotomilling						
Demolition						
Pavement Markings (Paint)						
Other Construction (List)						
Totals						

Disclosure of this information is REQUIRED to accomplish the statutory purpose as outlined in the "Illinois Procurement Code." Failure to comply will result in non-issuance of an "Authorization To Bid." This form has been approved by the State Forms Management Center.

Part III. Work Subcontracted to Others.

For each contract described in Part I, list all the work you have subcontracted to others.

	1	2	3	4	Awards Pending
Subcontractor					
Type of Work					
Subcontract Price					
Amount Uncompleted					
Subcontractor					
Type of Work					
Subcontract Price					
Amount Uncompleted					
Subcontractor					
Type of Work					
Subcontract Price					
Amount Uncompleted					
Subcontractor					
Type of Work					
Subcontract Price					
Amount Uncompleted					
Subcontractor					
Type of Work					
Subcontract Price					
Amount Uncompleted					
Total Uncompleted					

Notary

I, being duly sworn, do hereby declare this affidavit is a true and correct statement relating to ALL uncompleted contracts of the undersigned for Federal, State, County, City and private work, including ALL subcontract work, ALL pending low bids not yet awarded or rejected and ALL estimated completion dates.

Officer or Director

Title

Signature

Date

Company

Address

City

State

Zip Code

Subscribed and sworn to before me

this _____ day of _____, _____

(Signature of Notary Public)

My commission expires _____

(Notary Seal)

Add pages for additional contracts



Required Vendor Ethics Disclosure Statement

Failure to complete and return this form may result in delay or cancellation of the County's Contractual Obligation.

Date: _____

Bid/Contract/PO #: 22-PVMTC-17-GM

Company Name:	Company Contact:
Contact Phone:	Contact Email:

The DuPage County Procurement Ordinance requires the following written disclosures prior to award:

1. Every contractor, union, or vendor that is seeking or has previously obtained a contract, change orders to one (1) or more contracts, or two (2) or more individual contracts with the county resulting in an aggregate amount at or in excess of \$25,000, shall provide to Procurement Services Division a written disclosure of all political campaign contributions made by such contractor, union, or vendor within the current and previous calendar year to any incumbent county board member, county board chairman, or countywide elected official whose office the contract to be awarded will benefit. The contractor, union or vendor shall update such disclosure annually during the term of a multi-year contract and prior to any change order or renewal requiring approval by the county board. For purposes of this disclosure requirement, "contractor or vendor" includes owners, officers, managers, lobbyists, agents, consultants, bond counsel and underwriters counsel, subcontractors and corporate entities under the control of the contracting person, and political action committees to which the contracting person has made contributions.

NONE (check here) - If no contributions have been made

Recipient	Donor	Description (e.g. cash, type of item, in-kind services, etc.)	Amount/Value	Date Made

2. All contractors and vendors who have obtained or are seeking contracts with the county shall disclose the names and contact information of their lobbyists, agents and representatives and all individuals who are or will be having contact with county officers or employees in relation to the contractor bid and shall update such disclosure with any changes that may occur.

NONE (check here) - If no contacts have been made

Lobbyists, Agents and Representatives and all individuals who are or will be having contact with county officers or employees in relation to the contract or bid	Telephone	Email

A contractor or vendor that knowingly violates these disclosure requirements is subject to penalties which may include, but are not limited to, the immediate cancellation of the contract and possible disbarment from future county contracts.

Continuing disclosure is required, and I agree to update this disclosure form as follows:

- If information changes, within five (5) days of change, or prior to county action, whichever is sooner
- 30 days prior to the optional renewal of any contract
- Annual disclosure for multi-year contracts on the anniversary of said contract
- With any request for change order except those issued by the county for administrative adjustments

The full text for the county's ethics and procurement policies and ordinances are available at:

<http://www.dupageco.org/CountyBoard/Policies/>

I hereby acknowledge that I have received, have read, and understand these requirements.

Authorized Signature

Printed Name

Title

Date

Attach additional sheets if necessary. Sign each sheet and number each page. Page _____ of _____ (total number of pages)

Request for Taxpayer Identification Number and Certification

**Give Form to the
 requester. Do not
 send to the IRS.**

▶ Go to www.irs.gov/FormW9 for instructions and the latest information.

Print or type. See Specific Instructions on page 3.	1 Name (as shown on your income tax return). Name is required on this line; do not leave this line blank.		
	2 Business name/disregarded entity name, if different from above		
	3 Check appropriate box for federal tax classification of the person whose name is entered on line 1. Check only one of the following seven boxes.		4 Exemptions (codes apply only to certain entities, not individuals; see instructions on page 3):
	<input type="checkbox"/> Individual/sole proprietor or single-member LLC <input type="checkbox"/> C Corporation <input type="checkbox"/> S Corporation <input type="checkbox"/> Partnership <input type="checkbox"/> Trust/estate		Exempt payee code (if any) _____
	<input type="checkbox"/> Limited liability company. Enter the tax classification (C=C corporation, S=S corporation, P=Partnership) ▶ _____ Note: Check the appropriate box in the line above for the tax classification of the single-member owner. Do not check LLC if the LLC is classified as a single-member LLC that is disregarded from the owner unless the owner of the LLC is another LLC that is not disregarded from the owner for U.S. federal tax purposes. Otherwise, a single-member LLC that is disregarded from the owner should check the appropriate box for the tax classification of its owner.		Exemption from FATCA reporting code (if any) _____
	<input type="checkbox"/> Other (see instructions) ▶ _____		<i>(Applies to accounts maintained outside the U.S.)</i>
	5 Address (number, street, and apt. or suite no.) See instructions.		Requester's name and address (optional)
6 City, state, and ZIP code			
7 List account number(s) here (optional)			

Part I Taxpayer Identification Number (TIN)

Enter your TIN in the appropriate box. The TIN provided must match the name given on line 1 to avoid backup withholding. For individuals, this is generally your social security number (SSN). However, for a resident alien, sole proprietor, or disregarded entity, see the instructions for Part I, later. For other entities, it is your employer identification number (EIN). If you do not have a number, see *How to get a TIN*, later.

Note: If the account is in more than one name, see the instructions for line 1. Also see *What Name and Number To Give the Requester* for guidelines on whose number to enter.

Social security number									
-				-					
or									
Employer identification number									
-									

Part II Certification

Under penalties of perjury, I certify that:

1. The number shown on this form is my correct taxpayer identification number (or I am waiting for a number to be issued to me); and
2. I am not subject to backup withholding because: (a) I am exempt from backup withholding, or (b) I have not been notified by the Internal Revenue Service (IRS) that I am subject to backup withholding as a result of a failure to report all interest or dividends, or (c) the IRS has notified me that I am no longer subject to backup withholding; and
3. I am a U.S. citizen or other U.S. person (defined below); and
4. The FATCA code(s) entered on this form (if any) indicating that I am exempt from FATCA reporting is correct.

Certification instructions. You must cross out item 2 above if you have been notified by the IRS that you are currently subject to backup withholding because you have failed to report all interest and dividends on your tax return. For real estate transactions, item 2 does not apply. For mortgage interest paid, acquisition or abandonment of secured property, cancellation of debt, contributions to an individual retirement arrangement (IRA), and generally, payments other than interest and dividends, you are not required to sign the certification, but you must provide your correct TIN. See the instructions for Part II, later.

Sign Here	Signature of U.S. person ▶	Date ▶
------------------	-----------------------------------	---------------

General Instructions

Section references are to the Internal Revenue Code unless otherwise noted.

Future developments. For the latest information about developments related to Form W-9 and its instructions, such as legislation enacted after they were published, go to www.irs.gov/FormW9.

Purpose of Form

An individual or entity (Form W-9 requester) who is required to file an information return with the IRS must obtain your correct taxpayer identification number (TIN) which may be your social security number (SSN), individual taxpayer identification number (ITIN), adoption taxpayer identification number (ATIN), or employer identification number (EIN), to report on an information return the amount paid to you, or other amount reportable on an information return. Examples of information returns include, but are not limited to, the following.

- Form 1099-INT (interest earned or paid)

- Form 1099-DIV (dividends, including those from stocks or mutual funds)
- Form 1099-MISC (various types of income, prizes, awards, or gross proceeds)
- Form 1099-B (stock or mutual fund sales and certain other transactions by brokers)
- Form 1099-S (proceeds from real estate transactions)
- Form 1099-K (merchant card and third party network transactions)
- Form 1098 (home mortgage interest), 1098-E (student loan interest), 1098-T (tuition)
- Form 1099-C (canceled debt)
- Form 1099-A (acquisition or abandonment of secured property)

Use Form W-9 only if you are a U.S. person (including a resident alien), to provide your correct TIN.

If you do not return Form W-9 to the requester with a TIN, you might be subject to backup withholding. See What is backup withholding, later.

By signing the filled-out form, you:

1. Certify that the TIN you are giving is correct (or you are waiting for a number to be issued),
2. Certify that you are not subject to backup withholding, or
3. Claim exemption from backup withholding if you are a U.S. exempt payee. If applicable, you are also certifying that as a U.S. person, your allocable share of any partnership income from a U.S. trade or business is not subject to the withholding tax on foreign partners' share of effectively connected income, and
4. Certify that FATCA code(s) entered on this form (if any) indicating that you are exempt from the FATCA reporting, is correct. See *What is FATCA reporting*, later, for further information.

Note: If you are a U.S. person and a requester gives you a form other than Form W-9 to request your TIN, you must use the requester's form if it is substantially similar to this Form W-9.

Definition of a U.S. person. For federal tax purposes, you are considered a U.S. person if you are:

- An individual who is a U.S. citizen or U.S. resident alien;
- A partnership, corporation, company, or association created or organized in the United States or under the laws of the United States;
- An estate (other than a foreign estate); or
- A domestic trust (as defined in Regulations section 301.7701-7).

Special rules for partnerships. Partnerships that conduct a trade or business in the United States are generally required to pay a withholding tax under section 1446 on any foreign partners' share of effectively connected taxable income from such business. Further, in certain cases where a Form W-9 has not been received, the rules under section 1446 require a partnership to presume that a partner is a foreign person, and pay the section 1446 withholding tax. Therefore, if you are a U.S. person that is a partner in a partnership conducting a trade or business in the United States, provide Form W-9 to the partnership to establish your U.S. status and avoid section 1446 withholding on your share of partnership income.

In the cases below, the following person must give Form W-9 to the partnership for purposes of establishing its U.S. status and avoiding withholding on its allocable share of net income from the partnership conducting a trade or business in the United States.

- In the case of a disregarded entity with a U.S. owner, the U.S. owner of the disregarded entity and not the entity;
- In the case of a grantor trust with a U.S. grantor or other U.S. owner, generally, the U.S. grantor or other U.S. owner of the grantor trust and not the trust; and
- In the case of a U.S. trust (other than a grantor trust), the U.S. trust (other than a grantor trust) and not the beneficiaries of the trust.

Foreign person. If you are a foreign person or the U.S. branch of a foreign bank that has elected to be treated as a U.S. person, do not use Form W-9. Instead, use the appropriate Form W-8 or Form 8233 (see Pub. 515, *Withholding of Tax on Nonresident Aliens and Foreign Entities*).

Nonresident alien who becomes a resident alien. Generally, only a nonresident alien individual may use the terms of a tax treaty to reduce or eliminate U.S. tax on certain types of income. However, most tax treaties contain a provision known as a "saving clause." Exceptions specified in the saving clause may permit an exemption from tax to continue for certain types of income even after the payee has otherwise become a U.S. resident alien for tax purposes.

If you are a U.S. resident alien who is relying on an exception contained in the saving clause of a tax treaty to claim an exemption from U.S. tax on certain types of income, you must attach a statement to Form W-9 that specifies the following five items.

1. The treaty country. Generally, this must be the same treaty under which you claimed exemption from tax as a nonresident alien.
2. The treaty article addressing the income.
3. The article number (or location) in the tax treaty that contains the saving clause and its exceptions.
4. The type and amount of income that qualifies for the exemption from tax.
5. Sufficient facts to justify the exemption from tax under the terms of the treaty article.

Example. Article 20 of the U.S.-China income tax treaty allows an exemption from tax for scholarship income received by a Chinese student temporarily present in the United States. Under U.S. law, this student will become a resident alien for tax purposes if his or her stay in the United States exceeds 5 calendar years. However, paragraph 2 of the first Protocol to the U.S.-China treaty (dated April 30, 1984) allows the provisions of Article 20 to continue to apply even after the Chinese student becomes a resident alien of the United States. A Chinese student who qualifies for this exception (under paragraph 2 of the first protocol) and is relying on this exception to claim an exemption from tax on his or her scholarship or fellowship income would attach to Form W-9 a statement that includes the information described above to support that exemption.

If you are a nonresident alien or a foreign entity, give the requester the appropriate completed Form W-8 or Form 8233.

Backup Withholding

What is backup withholding? Persons making certain payments to you must under certain conditions withhold and pay to the IRS 24% of such payments. This is called "backup withholding." Payments that may be subject to backup withholding include interest, tax-exempt interest, dividends, broker and barter exchange transactions, rents, royalties, nonemployee pay, payments made in settlement of payment card and third party network transactions, and certain payments from fishing boat operators. Real estate transactions are not subject to backup withholding.

You will not be subject to backup withholding on payments you receive if you give the requester your correct TIN, make the proper certifications, and report all your taxable interest and dividends on your tax return.

Payments you receive will be subject to backup withholding if:

1. You do not furnish your TIN to the requester,
2. You do not certify your TIN when required (see the instructions for Part II for details),
3. The IRS tells the requester that you furnished an incorrect TIN,
4. The IRS tells you that you are subject to backup withholding because you did not report all your interest and dividends on your tax return (for reportable interest and dividends only), or
5. You do not certify to the requester that you are not subject to backup withholding under 4 above (for reportable interest and dividend accounts opened after 1983 only).

Certain payees and payments are exempt from backup withholding. See *Exempt payee code*, later, and the separate Instructions for the Requester of Form W-9 for more information.

Also see *Special rules for partnerships*, earlier.

What is FATCA Reporting?

The Foreign Account Tax Compliance Act (FATCA) requires a participating foreign financial institution to report all United States account holders that are specified United States persons. Certain payees are exempt from FATCA reporting. See *Exemption from FATCA reporting code*, later, and the Instructions for the Requester of Form W-9 for more information.

Updating Your Information

You must provide updated information to any person to whom you claimed to be an exempt payee if you are no longer an exempt payee and anticipate receiving reportable payments in the future from this person. For example, you may need to provide updated information if you are a C corporation that elects to be an S corporation, or if you no longer are tax exempt. In addition, you must furnish a new Form W-9 if the name or TIN changes for the account; for example, if the grantor of a grantor trust dies.

Penalties

Failure to furnish TIN. If you fail to furnish your correct TIN to a requester, you are subject to a penalty of \$50 for each such failure unless your failure is due to reasonable cause and not to willful neglect.

Civil penalty for false information with respect to withholding. If you make a false statement with no reasonable basis that results in no backup withholding, you are subject to a \$500 penalty.

Criminal penalty for falsifying information. Willfully falsifying certifications or affirmations may subject you to criminal penalties including fines and/or imprisonment.

Misuse of TINs. If the requester discloses or uses TINs in violation of federal law, the requester may be subject to civil and criminal penalties.

Specific Instructions

Line 1

You must enter one of the following on this line; **do not** leave this line blank. The name should match the name on your tax return.

If this Form W-9 is for a joint account (other than an account maintained by a foreign financial institution (FFI)), list first, and then circle, the name of the person or entity whose number you entered in Part I of Form W-9. If you are providing Form W-9 to an FFI to document a joint account, each holder of the account that is a U.S. person must provide a Form W-9.

a. **Individual.** Generally, enter the name shown on your tax return. If you have changed your last name without informing the Social Security Administration (SSA) of the name change, enter your first name, the last name as shown on your social security card, and your new last name.

Note: ITIN applicant: Enter your individual name as it was entered on your Form W-7 application, line 1a. This should also be the same as the name you entered on the Form 1040/1040A/1040EZ you filed with your application.

b. **Sole proprietor or single-member LLC.** Enter your individual name as shown on your 1040/1040A/1040EZ on line 1. You may enter your business, trade, or “doing business as” (DBA) name on line 2.

c. **Partnership, LLC that is not a single-member LLC, C corporation, or S corporation.** Enter the entity’s name as shown on the entity’s tax return on line 1 and any business, trade, or DBA name on line 2.

d. **Other entities.** Enter your name as shown on required U.S. federal tax documents on line 1. This name should match the name shown on the charter or other legal document creating the entity. You may enter any business, trade, or DBA name on line 2.

e. **Disregarded entity.** For U.S. federal tax purposes, an entity that is disregarded as an entity separate from its owner is treated as a “disregarded entity.” See Regulations section 301.7701-2(c)(2)(iii). Enter the owner’s name on line 1. The name of the entity entered on line 1 should never be a disregarded entity. The name on line 1 should be the name shown on the income tax return on which the income should be reported. For example, if a foreign LLC that is treated as a disregarded entity for U.S. federal tax purposes has a single owner that is a U.S. person, the U.S. owner’s name is required to be provided on line 1. If the direct owner of the entity is also a disregarded entity, enter the first owner that is not disregarded for federal tax purposes. Enter the disregarded entity’s name on line 2, “Business name/disregarded entity name.” If the owner of the disregarded entity is a foreign person, the owner must complete an appropriate Form W-8 instead of a Form W-9. This is the case even if the foreign person has a U.S. TIN.

Line 2

If you have a business name, trade name, DBA name, or disregarded entity name, you may enter it on line 2.

Line 3

Check the appropriate box on line 3 for the U.S. federal tax classification of the person whose name is entered on line 1. Check only one box on line 3.

IF the entity/person on line 1 is a(n) . . .	THEN check the box for . . .
• Corporation	Corporation
• Individual • Sole proprietorship, or • Single-member limited liability company (LLC) owned by an individual and disregarded for U.S. federal tax purposes.	Individual/sole proprietor or single-member LLC
• LLC treated as a partnership for U.S. federal tax purposes, • LLC that has filed Form 8832 or 2553 to be taxed as a corporation, or • LLC that is disregarded as an entity separate from its owner but the owner is another LLC that is not disregarded for U.S. federal tax purposes.	Limited liability company and enter the appropriate tax classification. (P= Partnership; C= C corporation; or S= S corporation)
• Partnership	Partnership
• Trust/estate	Trust/estate

Line 4, Exemptions

If you are exempt from backup withholding and/or FATCA reporting, enter in the appropriate space on line 4 any code(s) that may apply to you.

Exempt payee code.

- Generally, individuals (including sole proprietors) are not exempt from backup withholding.
- Except as provided below, corporations are exempt from backup withholding for certain payments, including interest and dividends.
- Corporations are not exempt from backup withholding for payments made in settlement of payment card or third party network transactions.
- Corporations are not exempt from backup withholding with respect to attorneys’ fees or gross proceeds paid to attorneys, and corporations that provide medical or health care services are not exempt with respect to payments reportable on Form 1099-MISC.

The following codes identify payees that are exempt from backup withholding. Enter the appropriate code in the space in line 4.

- 1—An organization exempt from tax under section 501(a), any IRA, or a custodial account under section 403(b)(7) if the account satisfies the requirements of section 401(f)(2)
- 2—The United States or any of its agencies or instrumentalities
- 3—A state, the District of Columbia, a U.S. commonwealth or possession, or any of their political subdivisions or instrumentalities
- 4—A foreign government or any of its political subdivisions, agencies, or instrumentalities
- 5—A corporation
- 6—A dealer in securities or commodities required to register in the United States, the District of Columbia, or a U.S. commonwealth or possession
- 7—A futures commission merchant registered with the Commodity Futures Trading Commission
- 8—A real estate investment trust
- 9—An entity registered at all times during the tax year under the Investment Company Act of 1940
- 10—A common trust fund operated by a bank under section 584(a)
- 11—A financial institution
- 12—A middleman known in the investment community as a nominee or custodian
- 13—A trust exempt from tax under section 664 or described in section 4947

The following chart shows types of payments that may be exempt from backup withholding. The chart applies to the exempt payees listed above, 1 through 13.

IF the payment is for . . .	THEN the payment is exempt for . . .
Interest and dividend payments	All exempt payees except for 7
Broker transactions	Exempt payees 1 through 4 and 6 through 11 and all C corporations. S corporations must not enter an exempt payee code because they are exempt only for sales of noncovered securities acquired prior to 2012.
Barter exchange transactions and patronage dividends	Exempt payees 1 through 4
Payments over \$600 required to be reported and direct sales over \$5,000 ¹	Generally, exempt payees 1 through 5 ²
Payments made in settlement of payment card or third party network transactions	Exempt payees 1 through 4

¹ See Form 1099-MISC, Miscellaneous Income, and its instructions.

² However, the following payments made to a corporation and reportable on Form 1099-MISC are not exempt from backup withholding: medical and health care payments, attorneys' fees, gross proceeds paid to an attorney reportable under section 6045(f), and payments for services paid by a federal executive agency.

Exemption from FATCA reporting code. The following codes identify payees that are exempt from reporting under FATCA. These codes apply to persons submitting this form for accounts maintained outside of the United States by certain foreign financial institutions. Therefore, if you are only submitting this form for an account you hold in the United States, you may leave this field blank. Consult with the person requesting this form if you are uncertain if the financial institution is subject to these requirements. A requester may indicate that a code is not required by providing you with a Form W-9 with "Not Applicable" (or any similar indication) written or printed on the line for a FATCA exemption code.

A—An organization exempt from tax under section 501(a) or any individual retirement plan as defined in section 7701(a)(37)

B—The United States or any of its agencies or instrumentalities

C—A state, the District of Columbia, a U.S. commonwealth or possession, or any of their political subdivisions or instrumentalities

D—A corporation the stock of which is regularly traded on one or more established securities markets, as described in Regulations section 1.1472-1(c)(1)(i)

E—A corporation that is a member of the same expanded affiliated group as a corporation described in Regulations section 1.1472-1(c)(1)(i)

F—A dealer in securities, commodities, or derivative financial instruments (including notional principal contracts, futures, forwards, and options) that is registered as such under the laws of the United States or any state

G—A real estate investment trust

H—A regulated investment company as defined in section 851 or an entity registered at all times during the tax year under the Investment Company Act of 1940

I—A common trust fund as defined in section 584(a)

J—A bank as defined in section 581

K—A broker

L—A trust exempt from tax under section 664 or described in section 4947(a)(1)

M—A tax exempt trust under a section 403(b) plan or section 457(g) plan

Note: You may wish to consult with the financial institution requesting this form to determine whether the FATCA code and/or exempt payee code should be completed.

Line 5

Enter your address (number, street, and apartment or suite number). This is where the requester of this Form W-9 will mail your information returns. If this address differs from the one the requester already has on file, write NEW at the top. If a new address is provided, there is still a chance the old address will be used until the payor changes your address in their records.

Line 6

Enter your city, state, and ZIP code.

Part I. Taxpayer Identification Number (TIN)

Enter your TIN in the appropriate box. If you are a resident alien and you do not have and are not eligible to get an SSN, your TIN is your IRS individual taxpayer identification number (ITIN). Enter it in the social security number box. If you do not have an ITIN, see *How to get a TIN* below.

If you are a sole proprietor and you have an EIN, you may enter either your SSN or EIN.

If you are a single-member LLC that is disregarded as an entity separate from its owner, enter the owner's SSN (or EIN, if the owner has one). Do not enter the disregarded entity's EIN. If the LLC is classified as a corporation or partnership, enter the entity's EIN.

Note: See *What Name and Number To Give the Requester*, later, for further clarification of name and TIN combinations.

How to get a TIN. If you do not have a TIN, apply for one immediately. To apply for an SSN, get Form SS-5, Application for a Social Security Card, from your local SSA office or get this form online at www.SSA.gov. You may also get this form by calling 1-800-772-1213. Use Form W-7, Application for IRS Individual Taxpayer Identification Number, to apply for an ITIN, or Form SS-4, Application for Employer Identification Number, to apply for an EIN. You can apply for an EIN online by accessing the IRS website at www.irs.gov/Businesses and clicking on Employer Identification Number (EIN) under Starting a Business. Go to www.irs.gov/Forms to view, download, or print Form W-7 and/or Form SS-4. Or, you can go to www.irs.gov/OrderForms to place an order and have Form W-7 and/or SS-4 mailed to you within 10 business days.

If you are asked to complete Form W-9 but do not have a TIN, apply for a TIN and write "Applied For" in the space for the TIN, sign and date the form, and give it to the requester. For interest and dividend payments, and certain payments made with respect to readily tradable instruments, generally you will have 60 days to get a TIN and give it to the requester before you are subject to backup withholding on payments. The 60-day rule does not apply to other types of payments. You will be subject to backup withholding on all such payments until you provide your TIN to the requester.

Note: Entering "Applied For" means that you have already applied for a TIN or that you intend to apply for one soon.

Caution: A disregarded U.S. entity that has a foreign owner must use the appropriate Form W-8.

Part II. Certification

To establish to the withholding agent that you are a U.S. person, or resident alien, sign Form W-9. You may be requested to sign by the withholding agent even if item 1, 4, or 5 below indicates otherwise.

For a joint account, only the person whose TIN is shown in Part I should sign (when required). In the case of a disregarded entity, the person identified on line 1 must sign. Exempt payees, see *Exempt payee code*, earlier.

Signature requirements. Complete the certification as indicated in items 1 through 5 below.

1. Interest, dividend, and barter exchange accounts opened before 1984 and broker accounts considered active during 1983.

You must give your correct TIN, but you do not have to sign the certification.

2. Interest, dividend, broker, and barter exchange accounts opened after 1983 and broker accounts considered inactive during 1983.

You must sign the certification or backup withholding will apply. If you are subject to backup withholding and you are merely providing your correct TIN to the requester, you must cross out item 2 in the certification before signing the form.

3. Real estate transactions.

You must sign the certification. You may cross out item 2 of the certification.

4. Other payments.

You must give your correct TIN, but you do not have to sign the certification unless you have been notified that you have previously given an incorrect TIN. "Other payments" include payments made in the course of the requester's trade or business for rents, royalties, goods (other than bills for merchandise), medical and health care services (including payments to corporations), payments to a nonemployee for services, payments made in settlement of payment card and third party network transactions, payments to certain fishing boat crew members and fishermen, and gross proceeds paid to attorneys (including payments to corporations).

5. Mortgage interest paid by you, acquisition or abandonment of secured property, cancellation of debt, qualified tuition program payments (under section 529), ABLE accounts (under section 529A), IRA, Coverdell ESA, Archer MSA or HSA contributions or distributions, and pension distributions.

You must give your correct TIN, but you do not have to sign the certification.

What Name and Number To Give the Requester

For this type of account:	Give name and SSN of:
1. Individual	The individual
2. Two or more individuals (joint account) other than an account maintained by an FFI	The actual owner of the account or, if combined funds, the first individual on the account ¹
3. Two or more U.S. persons (joint account maintained by an FFI)	Each holder of the account
4. Custodial account of a minor (Uniform Gift to Minors Act)	The minor ²
5. a. The usual revocable savings trust (grantor is also trustee)	The grantor-trustee ¹
b. So-called trust account that is not a legal or valid trust under state law	The actual owner ¹
6. Sole proprietorship or disregarded entity owned by an individual	The owner ³
7. Grantor trust filing under Optional Form 1099 Filing Method 1 (see Regulations section 1.671-4(b)(2)(i)(A))	The grantor*
For this type of account:	Give name and EIN of:
8. Disregarded entity not owned by an individual	The owner
9. A valid trust, estate, or pension trust	Legal entity ⁴
10. Corporation or LLC electing corporate status on Form 8832 or Form 2553	The corporation
11. Association, club, religious, charitable, educational, or other tax-exempt organization	The organization
12. Partnership or multi-member LLC	The partnership
13. A broker or registered nominee	The broker or nominee

For this type of account:	Give name and EIN of:
14. Account with the Department of Agriculture in the name of a public entity (such as a state or local government, school district, or prison) that receives agricultural program payments	The public entity
15. Grantor trust filing under the Form 1041 Filing Method or the Optional Form 1099 Filing Method 2 (see Regulations section 1.671-4(b)(2)(i)(B))	The trust

¹ List first and circle the name of the person whose number you furnish. If only one person on a joint account has an SSN, that person's number must be furnished.

² Circle the minor's name and furnish the minor's SSN.

³ You must show your individual name and you may also enter your business or DBA name on the "Business name/disregarded entity" name line. You may use either your SSN or EIN (if you have one), but the IRS encourages you to use your SSN.

⁴ List first and circle the name of the trust, estate, or pension trust. (Do not furnish the TIN of the personal representative or trustee unless the legal entity itself is not designated in the account title.) Also see *Special rules for partnerships*, earlier.

*Note: The grantor also must provide a Form W-9 to trustee of trust.

Note: If no name is circled when more than one name is listed, the number will be considered to be that of the first name listed.

Secure Your Tax Records From Identity Theft

Identity theft occurs when someone uses your personal information such as your name, SSN, or other identifying information, without your permission, to commit fraud or other crimes. An identity thief may use your SSN to get a job or may file a tax return using your SSN to receive a refund.

To reduce your risk:

- Protect your SSN,
- Ensure your employer is protecting your SSN, and
- Be careful when choosing a tax preparer.

If your tax records are affected by identity theft and you receive a notice from the IRS, respond right away to the name and phone number printed on the IRS notice or letter.

If your tax records are not currently affected by identity theft but you think you are at risk due to a lost or stolen purse or wallet, questionable credit card activity or credit report, contact the IRS Identity Theft Hotline at 1-800-908-4490 or submit Form 14039.

For more information, see Pub. 5027, Identity Theft Information for Taxpayers.

Victims of identity theft who are experiencing economic harm or a systemic problem, or are seeking help in resolving tax problems that have not been resolved through normal channels, may be eligible for Taxpayer Advocate Service (TAS) assistance. You can reach TAS by calling the TAS toll-free case intake line at 1-877-777-4778 or TTY/TDD 1-800-829-4059.

Protect yourself from suspicious emails or phishing schemes.

Phishing is the creation and use of email and websites designed to mimic legitimate business emails and websites. The most common act is sending an email to a user falsely claiming to be an established legitimate enterprise in an attempt to scam the user into surrendering private information that will be used for identity theft.

The IRS does not initiate contacts with taxpayers via emails. Also, the IRS does not request personal detailed information through email or ask taxpayers for the PIN numbers, passwords, or similar secret access information for their credit card, bank, or other financial accounts.

If you receive an unsolicited email claiming to be from the IRS, forward this message to phishing@irs.gov. You may also report misuse of the IRS name, logo, or other IRS property to the Treasury Inspector General for Tax Administration (TIGTA) at 1-800-366-4484. You can forward suspicious emails to the Federal Trade Commission at spam@uce.gov or report them at www.ftc.gov/complaint. You can contact the FTC at www.ftc.gov/idtheft or 877-IDTHEFT (877-438-4338). If you have been the victim of identity theft, see www.IdentityTheft.gov and Pub. 5027.

Visit www.irs.gov/IdentityTheft to learn more about identity theft and how to reduce your risk.

Privacy Act Notice

Section 6109 of the Internal Revenue Code requires you to provide your correct TIN to persons (including federal agencies) who are required to file information returns with the IRS to report interest, dividends, or certain other income paid to you; mortgage interest you paid; the acquisition or abandonment of secured property; the cancellation of debt; or contributions you made to an IRA, Archer MSA, or HSA. The person collecting this form uses the information on the form to file information returns with the IRS, reporting the above information. Routine uses of this information include giving it to the Department of Justice for civil and criminal litigation and to cities, states, the District of Columbia, and U.S. commonwealths and possessions for use in administering their laws. The information also may be disclosed to other countries under a treaty, to federal and state agencies to enforce civil and criminal laws, or to federal law enforcement and intelligence agencies to combat terrorism. You must provide your TIN whether or not you are required to file a tax return. Under section 3406, payers must generally withhold a percentage of taxable interest, dividend, and certain other payments to a payee who does not give a TIN to the payer. Certain penalties may also apply for providing false or fraudulent information.

REFERENCES

All bidders must provide three (3) projects of a similar nature as being performed in the immediate past five (5) years with the name, address and telephone number of the contact person having knowledge of the project or three (3) references (name, address, and telephone number) with knowledge of the integrity and business practices of the contractor.

PROJECT	
FIRM	
ADDRESS	
CONTACT	
TELEPHONE	

PROJECT	
FIRM	
ADDRESS	
CONTACT	
TELEPHONE	

PROJECT	
FIRM	
ADDRESS	
CONTACT	
TELEPHONE	

Return With Bid

OPTION FOR BITUMINOUS MATERIALS COST ADJUSTMENT

The bidder shall submit this completed form with his/her bid. Failure to submit the form, or failure to fill out the form completely, shall make this contract exempt of bituminous materials cost adjustments. After award, this form, when submitted, shall become part of the contract.

Contract No.: _____

Company Name: _____

Contractor's Option:

Is your company opting to include this special provision as part of the contract?

Yes No

Signature: _____ **Date:** _____

Return With Bid

OPTION FOR FUEL COST ADJUSTMENT

The bidder shall submit this completed form with his/her bid. Failure to submit the form or properly complete contract number, company name, and sign and date the form shall make this contract exempt of fuel cost adjustments in all categories. Failure to indicate "Yes" for any category of work at the time of bid will make that category of work exempt from fuel cost adjustment. After award, this form, when submitted shall become part of the contract.

Contract No.: _____

Company Name: _____

Contractor's Option:

Is your company opting to include this special provision as part of the contract plans for the following categories of work?

- | | | |
|--|-----|--------------------------|
| Category A Earthwork. | Yes | <input type="checkbox"/> |
| Category B Subbases and Aggregate Base Courses | Yes | <input type="checkbox"/> |
| Category C HMA Bases, Pavements and Shoulders | Yes | <input type="checkbox"/> |
| Category D PCC Bases, Pavements and Shoulders | Yes | <input type="checkbox"/> |
| Category E Structures | Yes | <input type="checkbox"/> |

Signature: _____ **Date:** _____

TABLE OF CONTENTS



Table of Contents

PROPOSAL DOCUMENTS

BLR 12200

- Local Public Agency Formal Contract Proposal
- Notice to Bidders
- Proposal
- Contractor Certifications
- Signatures

BLR 12201 Schedule of Prices

BLR 12230 Local Agency Proposal Bid Bond

DuPage County – Apprenticeship or Training Program Certification

BLR 12326 Affidavit of Illinois Business Office

BC 57 Affidavit of Availability

DuPage County – Required Vendor Ethics Disclosure Statement

IRS Form W-9: Request for Taxpayer Identification Number and Certification

Three (3) References Form

LR 109-2 Option for Bituminous Materials Cost Adjustment

LR 109-3 Option for Fuel Cost Adjustment

PLANS 1

LOCATION MAP 2

GENERAL NOTES 3

SUMMARY OF QUANTITIES 7

ARMY TRAIL ROAD (C.H. 11)..... 9

 CONSTRUCTION NOTES..... 10

 TYPICAL SECTION..... 11

 DRAINAGE SCHEDULE..... 12

 PAVEMENT MARKING PLANS..... 13

GENEVA ROAD (C.H. 21)..... 19

 CONSTRUCTION NOTES..... 20

 TYPICAL SECTION..... 21

 DRAINAGE SCHEDULE..... 23

 PAVEMENT MARKING PLANS..... 24

POWIS ROAD (C.H. 18)..... 41

 CONSTRUCTION NOTES..... 42

 TYPICAL SECTION..... 43

 PAVEMENT MARKING PLANS..... 44

SPECIAL PROVISIONS 49

 BIDDING REQUIREMENTS AND CONDITIONS FOR CONTRACT PROPOSALS 49

 SECTION 107 LEGAL REGULATIONS AND RESPONSIBILITY TO PUBLIC 50

 SECTION 108 PROSECUTION AND PROGRESS 51

 SECTION 109 MEASUREMENT AND PAYMENT 51

 SECTION 202 EARTH AND ROCK EXCAVATION 51

 SECTION 208 TRENCH BACKFILL 51

 SECTION 250 SEEDING 51

SECTION 311	GRANULAR SUBBASE	52
SECTION 358	REPAIR AND PREPARATION OF BASE COURSE	52
SECTION 406	HOT-MIX ASPHALT BINDER AND SURFACE COURSE	52
	HOT-MIX-ASPHALT – ECHELON PAVING	53
SECTION 440	REMOVAL OF EXISTING PAVEMENT AND APPURTENANCES	54
SECTION 602	CATCH BASIN, MANHOLE, INLET, DRAINAGE STRUCTURE, VALVE VAULT CONSTRUCTION, ADJUSTMENT AND RECONSTRUCTION	54
SECTION 604	FRAMES, GRATES, AND MEDIAN INLETS.....	55
SECTION 669	REMOVAL AND DISPOSAL OF REGULATED SUBSTANCES.....	55
SECTION 671	MOBILIZATION	55
SECTION 703	WORK ZONE PAVEMENT MARKING.....	55
SECTION 1105	PAVEMENT MARKING EQUIPMENT.....	55
	COMBINATION CONCRETE CURB AND GUTTER REMOVAL AND REPLACEMENT	56
	DRAINAGE STRUCTURE CLEAN AND PATCH	56
	DRAINAGE STRUCTURE TO BE ADJUSTED.....	56
	DRAINAGE STRUCTURE TO BE RECONSTRUCTED.....	56
	DRAINAGE STRUCTURE TO BE REMOVED	57
	EMERGENCY POTHOLE PATCHING	57
	FRAMES AND LIDS TO BE ADJUSTED, SPECIAL	58
	MODIFIED URETHANE PAVEMENT MARKING – RAISED MEDIAN	58
	PATH REMOVAL	58
	RECESSED REFLECTIVE PAVEMENT MARKERS	59
	SIDEWALK REMOVAL AND REPLACEMENT	59
	TEMPORARY STONE.....	60
	TRAFFIC CONTROL AND PROTECTION.....	60
	TRAFFIC CONTROL PLAN.....	61
	FRICITION AGGREGATE (D-1).....	62
	HOT-MIX ASPHALT BINDER AND SURFACE COURSE (D-1)	65
	HOT-MIX ASPHALT – MIXTURE DESIGN VERIFICATION AND PRODUCTION (D-1)	70
	PUBLIC CONVIENIENCE AND SAFETY (D-1).....	72
	RAILROAD FLAGGING	73
	CN FLAGGING AND CABLE LOCATION REQUIREMENTS AND REQUEST FORM.....	74
	CN RAILROAD RIGHT OF ENTRY.....	76
	CN RAILROAD CERTIFICATE OF INSURANCE EXAMPLE	82
	CN RAILROAD ACH PAYMENT DETAILS.....	83
	UNION PACIFIC CONTRACTOR ENDORSEMENT GENERAL CONDITIONS.....	84
DUPAGE COUNTY TRAFFIC SIGNAL SPECIAL PROVISIONS		93
	TRAFFIC SIGNAL GENERAL REQUIREMENTS.....	93
	DETECTOR LOOP REPLACEMENT	106
	ELECTRICAL CABLE	106
	MAINTENANCE OF EXISITNG TRAFFIC SIGNAL INSTALLATION.....	107
	MODIFY EXISTING CONTROLLER AND CABINET	109
	REMOVE EXISITNG TRAFFIC SIGNAL EQUIPMENT	109
Index for Supplemental Specifications		
Check Sheet For Recurring Special Provisions		
Check Sheet For Recurring Local Roads And Streets Special Provisions		
DuPage County Prevailing Wages as of March 7, 2022 (For use with LRS heck Sheet #12)		

BDE Special Provisions

- Compensable Delay Costs
- Construction Air Quality – Diesel Retrofit
- Hot Mix Asphalt – Patching
- Hot Mix Asphalt – Start of Production
- Subcontractor Mobilization Payments
- Vehicle and Equipment Warning Lights
- Work Zone Traffic Control Devices

Local Roads and Streets Special Provisions

- LR 107-2 Railroad Protective Liability Insurance for Local Lettings
- LR 109-2 Bituminous Materials Cost Adjustment for Local Lettings
- LR 109-3 Fuel Cost Adjustment for Local Lettings
- LR 1030-2 Local Quality Assurance/ Quality Management QC/QA

Highway Standard Drawings

- 000001 Standard Symbols, Abbreviations and Patterns
- 424001 Perpendicular Curb Ramps for Sidewalks
- 424006 Diagonal Curb Ramps for Sidewalks
- 424011 Corner Parallel Curb Ramps for Sidewalks
- 424016 Mid-Block Curb Ramps for Sidewalks
- 424021 Depressed Corner for Curb Ramps
- 424026 Entrance/Alley Pedestrian Crossings
- 424031 Median Pedestrian Crossings
- 442201 Class C and Class D Patches
- 602301 Inlet - Type A
- 604001 Frame and Lids Type 1
- 604086 Frame and Grate Type 23
- 606001 Concrete Curb Type B and Combination Concrete Curb and Gutter
- 701101 Off-Road Operations, Multilane, 15' to 24" From Pavement Edge
- 701301 Lane Closure, 2L, 2W, Short Time Operations
- 701421 Lane Closure, Multilane, Day Operations Only, For Speeds ≥ 45 mph to 55 mph
- 701427 Lane Closure, Multilane, Intermittent or Moving Operations, for speeds ≤ 40 MPH
- 701501 Urban Lane Closure 2L, 2W, Undivided
- 701502 Urban Lane Closure, 2L, 2W, with Bidirectional Left Turn Lane
- 701601 Urban Lane Closure, Multilane, 1W or 2W with NonTraversable Median
- 701602 Urban Lane Closure Multilane, 2W with Bidirectional Left Turn Lane
- 701606 Urban Lane Closure, 2W with Mountable Median
- 701611 Urban Half Road Closure, Multilane, 2W, with Mountable Median
- 701701 Urban Lane Closure, Multilane Intersection
- 701801 Sidewalk, Corner or Crosswalk Closure
- 701901 Traffic Control Devices
- 886001 Detector Loop Installations
- 886006 Typical layouts for Detection loops

DuPage County Details

- Butt Joint
- Commercial Driveway
- Pavement Markings and Pavement Markers
- Private Entrance
- Recessed Reflective Pavement Marker

SAG Frame and Lid
Traffic Signal Handhole Adjustment
Typical Turn Bays

IDOT District One Details

BD-08 Frame and Lids Adjustment when Milling
TC 10 Traffic Control and Protection for Side Roads, Intersections, and Driveways
TC 14 Traffic Control and Protection at Turn Bays (To Remain Open)
TC 16 Pavement Markings Letters and Symbols for Traffic Staging
TS 07 Detector Loop Installation Details for Roadway Resurfacing

2022 PAVEMENT MAINTENANCE NORTH REGION

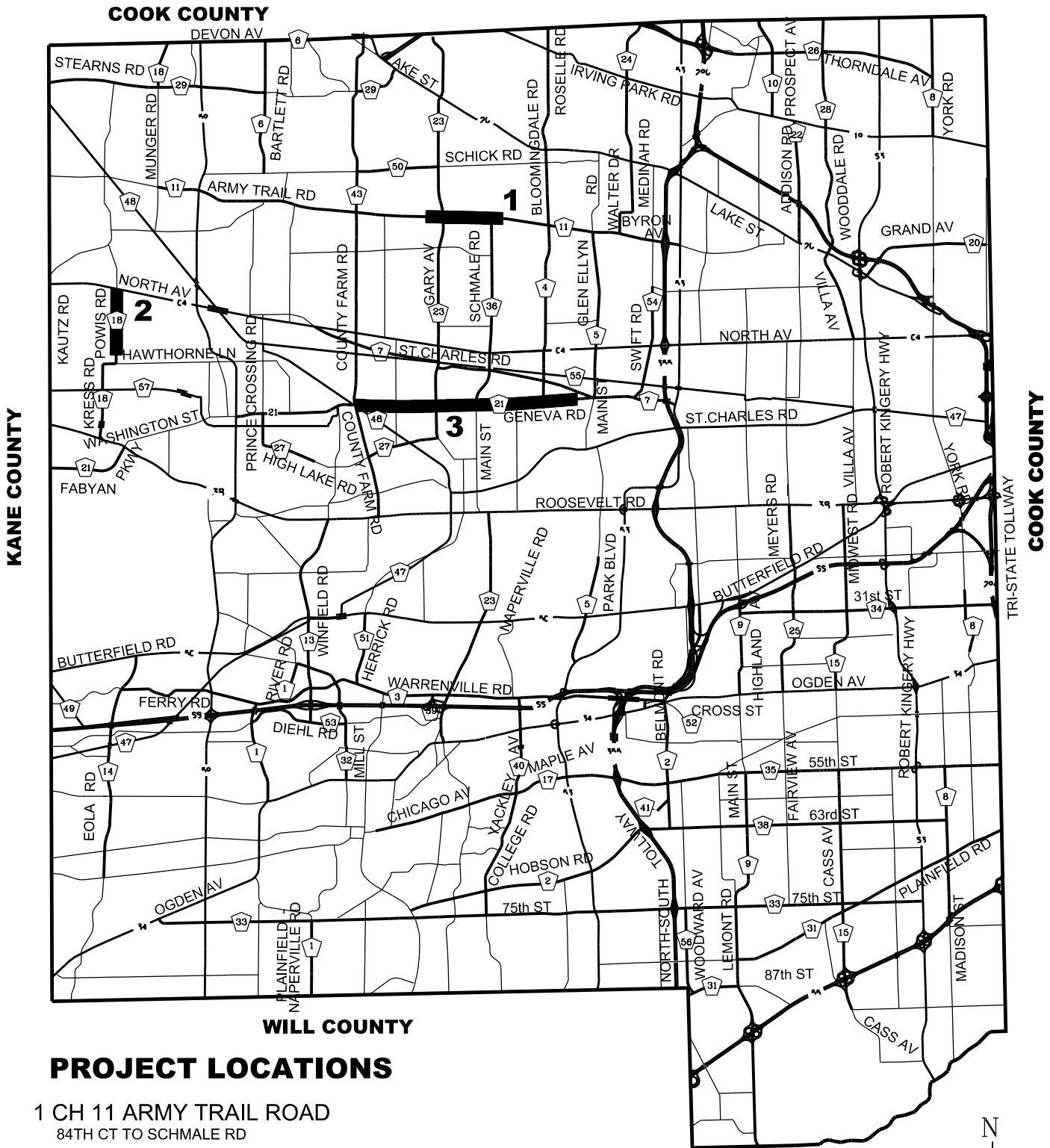

PROJECT LOCATIONS

- 1 CH 11 ARMY TRAIL ROAD
84TH CT TO SCHMALE RD
- 2 CH 18 POWIS ROAD
HAWTHORNE LN TO IL 64 (NORTH AVE)
- 3 CH 21 GENEVA ROAD
COUNTY FARM RD TO WESTERN AVE

COOK COUNTY

NOT TO SCALE

GENERAL NOTES
SUMMARY OF QUANTITIES



GENERAL NOTES

NO WORK SHALL COMMENCE UNTIL TRAFFIC CONTROL REQUIREMENTS ARE MET.

MAIL BOXES SHALL BE RELOCATED BY THE CONTRACTOR AS DIRECTED BY THE LOCAL POSTAL AUTHORITY. UNLESS INCLUDED AS A CONTRACT PAY ITEM, THIS WORK SHALL BE CONSIDERED TO BE INCLUDED IN THE CONTRACT UNIT PRICE FOR TRAFFIC CONTROL AND PROTECTION.

ALL UTILITIES, SCHOOL DISTRICTS, LOCAL POLICE, AND FIRE DEPARTMENTS SHALL BE NOTIFIED BY THE CONTRACTOR PRIOR TO THE START OF CONSTRUCTION.

UNLESS AUTHORIZED BY THE ENGINEER, ALL EXISTING ACCESS POINTS SHALL BE MAINTAINED AT ALL TIMES BY THE CONTRACTOR.

TREE REMOVAL

CLEARING

HEDGE REMOVAL

TREES NOT MARKED FOR REMOVAL SHALL BE CONSIDERED AS DESIGNATED TO BE SAVED AND SHALL BE PROTECTED UNDER THE PROVISIONS OF ARTICLE 201.05 OF THE STANDARD SPECIFICATIONS.

OVERHANGING LIMBS

OVERHANGING LIMBS ARE TO BE TRIMMED OR CUT OFF TO PROVIDE A MINIMUM VERTICAL CLEARANCE OF TWENTY (20) FEET FROM THE FINISHED SURFACE OF THE ROAD. CLEARANCE TO SIDEWALKS OR PATHS SHALL BE AS DIRECTED BY THE ENGINEER.

LIMB PRUNING SHALL BE UNDERTAKEN IN A TIMELY FASHION SO AS NOT TO INTERFERE WITH CONSTRUCTION.

ALL LIMBS, BRANCHES, AND OTHER DEBRIS RESULTING FROM THIS WORK SHALL BE DISPOSED OF BY THE CONTRACTOR AT HIS EXPENSE OUTSIDE THE LIMITS OF THE RIGHT-OF-WAY.

TOPSOIL

TOPSOIL SHALL BE PLACED TO A DEPTH OF SIX (6) INCHES AND BE MEASURED IN SQUARE YARDS.

TOPSOIL SHALL NOT BE STOCKPILED WITHIN THE LIMITS OF CONSTRUCTION; THE LOCATIONS OF TOPSOIL STOCKPILES WITHIN THE RIGHT-OF-WAY MUST BE APPROVED BY THE ENGINEER.

ROADWAY EXCAVATION

ALL EXISTING CULVERTS, STORM SEWERS, OR DRAINAGE STRUCTURES MARKED FOR REMOVAL ON THE PLANS OR DESIGNATED IN THE FIELD BY THE ENGINEER TO BE REMOVED SHALL BE REMOVED AND ANY EXCAVATION SHALL BE BACKFILLED WITH A GRANULAR MATERIAL MEETING THE SPECIFICATIONS FOR FA-1 OR FA-2.

THE CONTRACTOR WILL HAVE THE OPTION OF REMOVING EXISTING HOT-MIX ASPHALT PAVEMENT BY GRINDING OR EXCAVATING. IF THE HOT-MIX ASPHALT PAVEMENT IS REMOVED BY EXCAVATION, IT MAY NOT BE USED IN EMBANKMENT AREAS UNLESS SPECIFICALLY AUTHORIZED BY THE ENGINEER. HOT-MIX ASPHALT PAVEMENT REMOVED BY GRINDING MAY BE USED AS EMBANKMENT MATERIAL. NO HOT-MIX ASPHALT PAVEMENT SHALL BE REMOVED IN AREAS TO BE USED FOR TEMPORARY ROADWAY.

THE CONTRACTOR SHALL NOT CROSS COMPLETED BASE COURSE OR EXISTING PAVEMENT, NOT SCHEDULED TO BE REMOVED, WITH TRACK EQUIPMENT OR LOADED SCRAPERS.

ALL EMBANKMENTS AND SUB-GRADE SHALL BE COMPACTED TO THE SATISFACTION OF THE ENGINEER PRIOR TO PLACING AGGREGATE SUBGRADE OR SUB-BASE GRANULAR MATERIAL.

STORM SEWERS

STRUCTURES

UTILITIES

THE CONTRACTOR SHALL BE RESPONSIBLE FOR CONTACTING LOCAL AGENCIES MAINTAINING SANITARY SEWERS, WATERMAINS, AND STREET LIGHTS TO VERIFY THE MATERIALS AND METHODS ALLOWED FOR THE ADJUSTMENT, RELOCATION, OR EXTENSION OF THE UTILITY INVOLVED.

THE LOCATION AND ELEVATION OF EXISTING UTILITIES ARE APPROXIMATE AND ARE PROVIDED BY THE OWNERS. THE EXACT LOCATIONS AND ELEVATIONS ARE TO BE VERIFIED BY THE CONTRACTOR THROUGH THE OWNERS OF THE UTILITIES.

EMBANKMENTS SHALL BE COMPLETED TO THE SATISFACTION OF THE ENGINEER PRIOR TO EXCAVATION FOR STORM SEWER.

MANHOLES AND CATCH BASINS SHALL BE CONSTRUCTED WITH FLAT TOPS WHERE THE DIFFERENCE BETWEEN THE RIM ELEVATION AND INVERT ELEVATION IS LESS THAN SIX (6) FEET.

ADJUSTMENT OF STRUCTURES MAINTAINED BY OTHER AGENCIES SHALL BE MADE TO THE SATISFACTION OF THE ENGINEER AND THE AGENCY MAINTAINING THE STRUCTURE INVOLVED.

ALL MANHOLES AND INLETS SHALL HAVE POURED INVERTS.

ALL FIELD TILES ENCOUNTERED SHALL BE CAREFULLY PRESERVED AND CONNECTED TO PROPOSED DRAINAGE STRUCTURES, SEWERS, OR DITCHES, AS DIRECTED BY THE ENGINEER.

TRENCHES CROSSING TRAFFIC LANES MAY BE TEMPORARILY PATCHED WITH NOT LESS THAN FOUR (4) INCHES HMA. THE TEMPORARY PATCH SHALL BE MAINTAINED TO THE SATISFACTION OF THE ENGINEER UNTIL THE PERMANENT PATCH IS COMPLETED.

TRENCH BACKFILL

WHERE TRENCH BACKFILL IS REQUIRED, THE MATERIAL USED SHALL BE COMPACTED AS SPECIFIED IN ARTICLE 550.07 OF THE STANDARD SPECIFICATIONS USING METHOD ONE.

HOT-MIX ASPHALT SURFACE AND HOT-MIX ASPHALT BASE COURSE

HOT-MIX ASPHALT SURFACE COURSE SHALL NOT BE PLACED UNTIL ALL EARTH EXCAVATION, TOPSOIL PLACEMENT, BASE COURSE, AND HOT-MIX ASPHALT BINDER COURSE HAVE BEEN COMPLETED TO THE SATISFACTION OF THE ENGINEER.

HMA SURFACE REMOVAL SHALL BE “ZEROED” OUT AT ALL BUTT JOINTS TO PROVIDE A RAMP TO THE SATISFACTION OF THE ENGINEER FOR TRAFFIC TO SAFELY TRAVEL FROM MILLED TO EXISTING PAVEMENT. THE REMAINING HMA TO BE REMOVED SHALL BE REMOVED THE SAME DAY AS NEW HMA IS TO BE PLACED.

SAWCUT CONSTRUCTION JOINTS SHALL BE PROVIDED AT PAVED COMMERCIAL OR PRIVATE ENTRANCES AND AT ALL SIDE ROADS.

THE MAXIMUM COMPACTED THICKNESS OF ANY LIFT OF HOT-MIX ASPHALT BINDER OR SURFACE COURSE SHALL BE 2.5 INCHES.

THE MAXIMUM COMPACTED THICKNESS OF A LIFT OF HOT-MIX ASPHALT BASE COURSE SHALL BE FOUR (4) INCHES UNLESS OTHERWISE AUTHORIZED BY THE ENGINEER.

HOT-MIX ASPHALT BASE COURSE SHALL NOT BE PLACED ADJACENT TO CURB AND GUTTER UNTIL THE CURB AND GUTTER HAS BEEN BACKFILLED TO THE SATISFACTION OF THE ENGINEER.

TRAFFIC CONTROL AND PROTECTION

TRAFFIC CONTROL AND PROTECTION SHALL BE PERFORMED IN ACCORDANCE WITH THE TRAFFIC CONTROL PLAN, TRAFFIC SIGNAL PLANS, THESE NOTES, APPLICABLE SPECIAL PROVISIONS, AND SECTION 701 OF THE STANDARD SPECIFICATIONS AS AMENDED BY THE SPECIAL PROVISION FOR WORK ZONE TRAFFIC CONTROL (CHECK SHEET LRS 3).

THE TYPE III BARRICADES ARE TO BE PLACED IN ACCORDANCE WITH STANDARD 701901 UNLESS AUTHORIZED BY THE ENGINEER TO USE AN ALTERNATE ARRANGEMENT.

SIGNS ARE TO BE RELOCATED, MAINTAINED AND PROTECTED FROM DAMAGE BY THE CONTRACTOR AND ANY DAMAGED OR LOST SIGNS WILL BE REPLACED BY THE CONTRACTOR.

TYPE I OR TYPE II BARRICADES, DRUMS, OR VERTICAL PANELS WITH MONODIRECTIONAL STEADY-BURN LIGHTS SHALL BE REQUIRED ALONG TEMPORARY ROADS, DETOURS, AND SIDE STREETS TO DELINEATE THE TRAVELED WAY WITHIN THE CONSTRUCTION ZONE. THE MAXIMUM SPACING FOR THESE DEVICES SHALL BE 100 FEET CENTER TO CENTER.

ANY DROP OFF GREATER THAN THREE (3) INCHES WITHIN SIXTEEN (16) FEET OF A TRAVEL LANE SHALL BE PROTECTED BY TYPE I OR TYPE II BARRICADES, DRUMS OR VERTICAL PANELS WITH MONODIRECTIONAL STEADY-BURN LIGHTS AT 50 FOOT (MAXIMUM) CENTER TO CENTER SPACING. IF THE DROP OFF IS GREATER THAN TWENTY-FOUR (24) INCHES AND EXISTS FOR LONGER THAN 24 HOURS, IT SHALL BE PROTECTED BY TEMPORARY CONCRETE BARRIER. TEMPORARY CONCRETE BARRIER SHALL HAVE MONODIRECTIONAL STEADY-BURN LIGHTS AT 50 FOOT (MAXIMUM) CENTER TO CENTER SPACING. THE CONTRACTOR SHALL SCHEDULE HIS WORK AND OPERATIONS SUCH THAT A DROP OFF OF GREATER THAN

24 INCHES DOES NOT REMAIN WITHIN SIXTEEN FEET OF A TRAVEL LANE FOR MORE THAN 24 HOURS. THE CONTRACTOR MAY PLACE COMPACTED EXCAVATED MATERIAL, AGGREGATE, OR OTHER MATERIAL IN THE DROP OFF TO SATISFY THIS REQUIREMENT. THE PLANS INDICATE AREAS (IF ANY) IN WHICH THE DEPARTMENT EXPECTS THAT TEMPORARY CONCRETE BARRIER WILL BE REQUIRED FOR A DROP OFF OF GREATER THAN 24 INCHES TO REMAIN FOR MORE THAN 24 HOURS.

BARRICADES THAT MUST BE PLACED IN EXCAVATED AREAS SHALL HAVE LEG EXTENSIONS INSTALLED SUCH THAT THE TOP OF THE BARRICADE IS IN COMPLIANCE WITH THE HEIGHT REQUIREMENTS OF STANDARD 701901.

TYPE I OR TYPE II BARRICADES WITH TWO-WAY FLASHING LIGHTS SHALL BE REQUIRED AT ALL OPEN TRENCHES, EXCAVATIONS, OPEN OR EXPOSED SEWER STRUCTURES, TRANSVERSE PAVEMENT JOINTS, MATERIALS OR EQUIPMENT WITHIN THE RIGHT-OF-WAY (NUMBER AND SPACING DEPENDS ON THE CONDITIONS); AND AT LOCATIONS DESIGNATED BY THE ENGINEER OR LOCAL LAW ENFORCEMENT AGENCIES.

TYPE I, II AND / OR III BARRICADES WITH TWO-WAY FLASHING LIGHTS WILL BE REQUIRED TO GUIDE TRAFFIC AWAY FROM PAVEMENT AREAS CLOSED FOR CONSTRUCTION.

WHERE REQUIRED, TRAFFIC SIGNS SHALL BE RELOCATED FOR EACH STAGE OF CONSTRUCTION.

ARROW BOARDS WILL BE REQUIRED WHEN IMPLEMENTING ALL LANE CLOSURES.

CHANGEABLE MESSAGE SIGNS SHALL BE ERECTED AT EACH PROJECT LOCATION ONE WEEK PRIOR TO ANY WORK BEGINNING AND AS DIRECTED BY THE ENGINEER. ALL MESSAGES MUST BE APPROVED BY THE ENGINEER.

THE FOLLOWING TRAFFIC CONTROL STANDARDS ARE THE MINIMUM REQUIREMENTS FOR THE TRAFFIC CONTROL FOR THIS PROJECT:

- 701101 Off-Road Operations, Multilane, 15' to 24" From Pavement Edge
- 701301 Lane Closure, 2L, 2W, Short Time Operations
- 701421 Lane Closure, Multilane, Day Operations Only, For Speeds ≥ 45 mph to 55 mph
- 701427 Lane Closure, Multilane, Intermittent or Moving Operations, for speeds ≤ 40 MPH
- 701501 Urban Lane Closure 2L, 2W, Undivided
- 701502 Urban Lane Closure, 2L, 2W, with Bidirectional Left Turn Lane
- 701601 Urban Lane Closure, Multilane, 1W or 2W with NonTraversable Median
- 701602 Urban Lane Closure Multilane, 2W with Bidirectional Left Turn Lane
- 701606 Urban Lane Closure, 2W with Mountable Median
- 701611 Urban Half Road Closure, Multilane, 2W, with Mountable Median
- 701701 Urban Lane Closure, Multilane Intersection
- 701801 Sidewalk, Corner or Crosswalk Closure
- 701901 Traffic Control Devices

SUMMARY OF QUANTITIES

ITEM #	PAY ITEM	UNIT	ARMY TRAIL ROAD	GENEVA ROAD	POWIS ROAD	TOTAL QUANTITY
1	SEED BED PREPARATION	SQ YD	976	1511	0	2487
2	SEEDING, CLASS 2A	ACRE	0.20	0.31	0.00	0.51
3	EROSION CONTROL BLANKET	SQYD	976	1511	0	2487
4	REMOVAL AND DISPOSAL OF UNSUITABLE MATERIAL	CU YD	25	25	0	50
5	AGGREGATE WEDGE SHOULDER, TYPE B	TON	0	0	200	200
6	BITUMINOUS MATERIALS (TACK COAT)	POUND	46581	88797	12674	148052
7	LONGITUDINAL JOINT SEALANT	FOOT	31841	67797	7415	107053
8	MIXTURE FOR CRACKS, JOINTS AND FLANGEWAYS	TON	62	132	19	213
9	POLYMERIZED LEVELING BINDER MACHINE METHOD IL-4.75 N50	TON	2218	5673	810	8701
10	HMA BINDER COURSE, IL-19.0, N90	TON	1364	0	0	1364
11	HMA SURFACE COURSE, MIX "D", N70	TON	0	0	1619	1619
12	POLYMERIZED HMA SURFACE COURSE, MIX "E", N70	TON	6237	13237	0	19474
13	PORTLAND CEMENT CONCRETE SIDEWALK REMOVAL	SQ FT	3291	5726	0	9017
14	PORTLAND CEMENT CONCRETE SIDEWALK 5 INCH	SQ FT	3314	5684	0	8998
15	DETECTABLE WARNINGS	SQ FT	380	703	0	1083
16	HMA SURFACE REMOVAL 2.25"	SQ YD	0	0	18776	18776
17	HMA SURFACE REMOVAL 2.5"	SQ YD	61982	131550	0	193532
18	HMA SURFACE REMOVAL 4"	SQ YD	10540	0	0	10540
19	HMA SURFACE REMOVAL - BUTT JOINT	SQ YD	444	537	224	1205
20	COMBINATION CONCRETE CURB AND GUTTER REMOVAL AND REPLACEMENT	FOOT	3960	5975	0	9935
21	TEMPORARY STONE	TON	20	40	0	60
22	CLASS D PATCH, TYPE I, 10"	SQ YD	0	99	24	123
23	CLASS D PATCH, TYPE II, 10"	SQ YD	0	296	71	367
24	CLASS D PATCH, TYPE III, 10"	SQ YD	0	296	71	367
25	CLASS D PATCH, TYPE IV, 10"	SQ YD	0	99	24	123
26	CLASS D PATCH, TYPE I, 12"	SQ YD	0	66	0	66
27	CLASS D PATCH, TYPE II, 12"	SQ YD	0	198	0	198
28	CLASS D PATCH, TYPE III, 12"	SQ YD	0	198	0	198
29	CLASS D PATCH, TYPE IV, 12"	SQ YD	0	66	0	66
30	CLASS D PATCH, TYPE I, 13"	SQ YD	78	0	0	78
31	CLASS D PATCH, TYPE II, 13"	SQ YD	233	0	0	233
32	CLASS D PATCH, TYPE III, 13"	SQ YD	233	0	0	233
33	CLASS D PATCH, TYPE IV, 13"	SQ YD	78	0	0	78
34	DRAINAGE STRUCTURE TO BE RECONSTRUCTED	EACH	0	5	0	5
35	DRAINAGE STRUCTURE TO BE REMOVED	EACH	0	12	0	12
36	INLET TY. A	EACH	0	12	0	12
37	FRAME AND LIDS, TYPE 1	EACH	5	27	0	32
38	FRAMES AND GRATES, TYPE 23	EACH	6	2	0	8
39	DRAINAGE STRUCTURE TO BE ADJUSTED	EACH	20	44	0	64
40	DRAINAGE STRUCTURE CLEAN AND PATCH	EACH	13	16	0	29
41	FRAMES AND LIDS TO BE ADJUSTED, SPECIAL	EACH	12	53	0	65
42	SHORT TERM PAVEMENT MARKING	FOOT	4163	12441	3243	19847
* 43	THERMOPLASTIC PAVEMENT MARKING - LETTERS AND SYMBOLS	SQ FT	2333	1845	123	4301
* 44	THERMOPLASTIC PAVEMENT MARKING - LINE 4"	FOOT	16400	49245	23979	89624
* 45	THERMOPLASTIC PAVEMENT MARKING - LINE 6"	FOOT	7346	4963	0	12309
46	THERMOPLASTIC PAVEMENT MARKING - LINE 8"	FOOT	190	160	0	350
* 47	THERMOPLASTIC PAVEMENT MARKING - LINE 12"	FOOT	2728	2871	88	5687
* 48	THERMOPLASTIC PAVEMENT MARKING - LINE 24"	FOOT	834	844	72	1750
* 49	MODIFIED URETHANE PAVEMENT MARKING - RAISED MEDIAN	SQ FT	896	0	0	896

*Denotes Specialty Item

ITEM #	PAY ITEM	UNIT	ARMY TRAIL ROAD	GENEVA ROAD	POWIS ROAD	TOTAL QUANTITY
50	TEMPORARY PAINT PAVEMENT MARKING - LETTERS & SYMBOLS	SQ FT	1750	1384	92	3226
51	TEMPORARY PAINT PAVEMENT MARKING - LINE 4"	FOOT	90536	212468	38700	341704
52	TEMPORARY PAINT PAVEMENT MARKING - LINE 24"	FOOT	3336	3376	288	7000
53	RAISED REFLECTIVE PAVEMENT MARKER REMOVAL	EACH	38	0	0	38
* 54	RECESSED REFLECTIVE PAVEMENT MARKER	EACH	546	2157	282	2985
* 55	DETECTOR LOOP REPLACEMENT	FOOT	66	2563	0	2629
* 56	MAINTENANCE OF EXISTING TRAFFIC SIGNAL INSTALLATION	EACH	4	5	0	9
* 57	HANDHOLE TO BE ADJUSTED	EACH	2	0	0	2
* 58	RELOCATE EXISTING PEDESTRIAN PUSH BUTTON	EACH	7	14	0	21
* 59	REMOVE EXISTING PEDESTRIAN PUSH BUTTON	EACH	0	2	0	2
* 60	REMOVE EXISTING PEDESTRIAN SIGNAL HEAD	EACH	0	2	0	2
* 61	MODIFY EXISTING CONTROLLER AND CABINET	EACH	0	1	0	1
62	TRAFFIC CONTROL & PROTECTION	L SUM	-	-	-	1
63	CHANGEABLE MESSAGE SIGN	CAL DAY	56	56	42	154
64	RAILROAD PROTECTIVE LIABILITY INSURANCE	L SUM	-	-	-	1
65	RAILROAD FLAGGING	DOLLAR	-	-	-	15000
66	EMERGENCY POTHOLE PATCHING	DOLLAR	-	-	-	20000

* Denotes Specialty Item



CONSTRUCTION NOTES

1. The project will begin 1750 ft west of Gary Avenue and terminate 910 ft east of Schmale Road, and will include all side streets up to the county right of way as shown on the pavement marking plans and as determined by the engineer.
2. The proposed improvements include milling – 2 ½” of the existing HMA surface course, Class D pavement patching, curb and gutter removal and replacement and sidewalk removal and replacement as determined by the Engineer, detector loop replacement, ¾” polymerized leveling binder (machine method), IL – 4.75, N50, longitudinal joint sealant, 1 ¾” polymerized HMA surface course Mix E N70, pavement markings, recessed pavement markers, and storm sewer.
3. The milling thickness shall be increased to 4” on all approaches to the Gary Avenue intersection, the east and west approaches to Schmale Road and through these intersections. This area shall be paved with 2 ¼” HMA binder course, IL-19.0, N90 in place of the polymerized leveling binder. The 4” milling limits on the approaches are as follows and as directed by the Engineer:

EB Army Trail at Gary Ave – 325 ft west of stop bar
NB Gary Ave at Army Trail – 265 ft south of stop bar
WB Army Trail at Gary Ave – 215 ft east of stop bar
EB Army Trail at Schmale Rd – 300 ft west of stop bar
WB Army Trail at Schmale Rd – 300 ft east of stop bar

4. Longitudinal joint sealant shall be placed prior to the placement of the HMA surface course. It shall be placed at the lane line, center line, and turn lane paving joints. It shall also be placed at the edge of pavement across side streets.
5. The traffic signals located at the following intersections are maintained by the DuPage DOT:

Army Trail Road / Gary Avenue
Army Trail Road / Knollwood Drive
Army Trail Road / Springfield Drive
Army Trail Road / Butterfield Drive
Army Trail Road / Bloomingdale Square Shopping Center
Army Trail Road / Schmale Road
Gary Avenue / Stark Drive

The Contractor shall notify the DuPage County Division of Transportation 7 days prior to the removal of any loop detection.

6. Railroad Rights of Entry and Railroad Protective Liability Insurance must be obtained for this location. The ROE’s shall be obtained from Canadian National for the Chicago, Central and Pacific Railroad crossing DOT/AAR #289 891 V and crossing DOT/AAR #289 890 N. HMA surface removal shall not begin at this location prior to the Railroad Right of Entry being obtained.

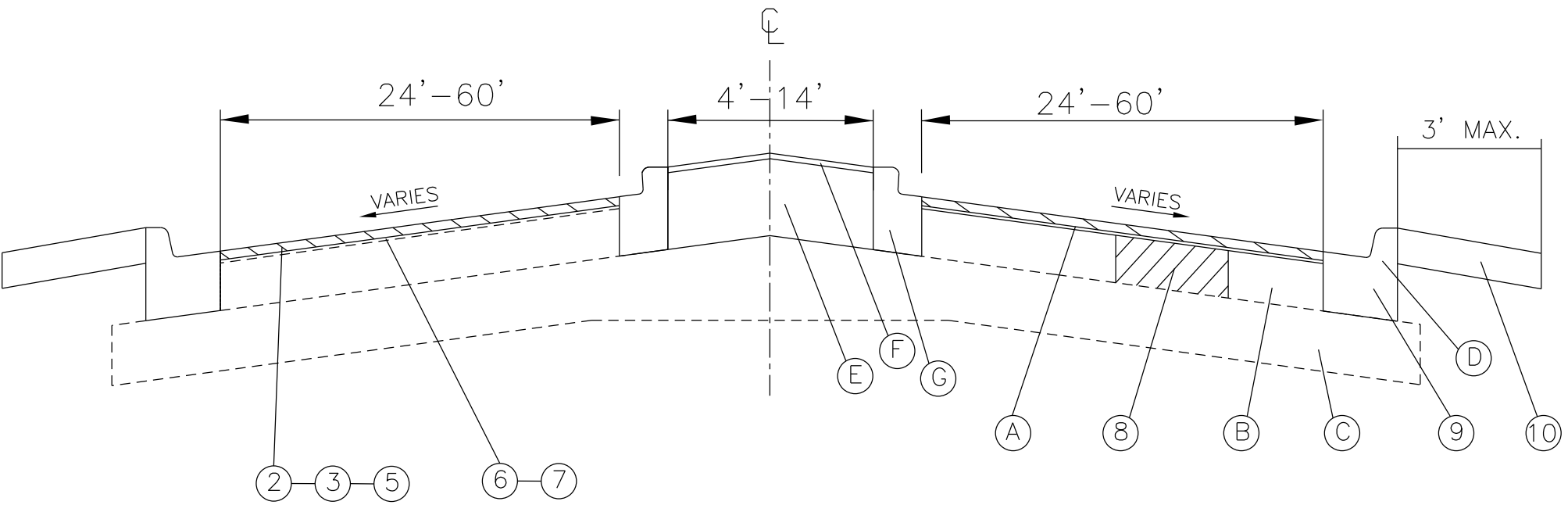

CH 11 / ARMY TRAIL ROAD
 84TH COURT TO SCHMALE ROAD
 TYPICAL SECTION

- ① HMA SURFACE REMOVAL, 2¼"
- ② HMA SURFACE REMOVAL, 2½"
- ③ POLY LEVEL BINDER, HMA, IL 4.75 N50 ¾"
- ④ HMA SURFACE COURSE MIX D, N70, 1½"
- ⑤ POLY HMA SURFACE COURSE MIX E, N70, 1¾"
- ⑥ BITUMINOUS MATERIALS (TACK COAT)
- ⑦ AGGREGATE FOR COVERING TACK COAT (AS NEEDED)
- ⑧ CLASS D PATCH, 13" (AS DIRECTED BY THE ENGINEER)
- ⑨ COMBINATION CONCRETE CURB & GUTTER REMOVAL AND REPLACEMENT (AS DIRECTED BY THE ENGINEER)
- ⑩ CLASS 2A SEED AND BLANKET MIN. 6" TOPSOIL

- Ⓐ EXISTING BITUMINOUS BINDER & SURFACE (4"-5.5")
- Ⓑ EXISTING PCC BASE COURSE 10"
- Ⓒ EXISTING AGGREGATE SUBGRADE
- Ⓓ EXISTING COMBINATION CONCRETE CURB AND GUTTER, TYPE B-6.24
- Ⓔ SUBBASE GRANULAR MATERIAL TYPE B
- Ⓕ BRICK PAVERS
- Ⓖ EXISTING COMBINATION CONCRETE CURB AND GUTTER, TYPE B-9.12

DRAINAGE SCHEDULE - ARMY TRAIL ROAD

STATION	LOCATION	TYPE
13+35	R	ADJUST
16+40	R	PATCH
28+95	R	PATCH
30+85	R	ADJUST
33+45	R	PATCH
41+00	R	ADJUST
43+48	R	ADJUST
53+55	R	PATCH
60+34	R	ADJUST
61+95	R	PATCH
64+85	R	ADJUST
69+87	R	ADJUST
72+45	R	PATCH
78+83	R	PATCH
82+83	R	ADJUST
12+64	L	ADJUST
16+38	L	PATCH
33+45	L	ADJUST
36+00	L	ADJUST
41+00	L	ADJUST
43+48	L	ADJUST
54+12	L	ADJUST
56+97	L	ADJUST
59+13	L	ADJUST
73+53	L	PATCH
77+30	L	ADJUST
78+83	L	PATCH
80+84	L	PATCH
82+83	L	PATCH
83+91	L	PATCH
84+27	L	ADJUST

NOTES:

1.) THE LOCATIONS OF TRAFFIC SIGNAL HANDHOLES AND DETECTOR LOOPS ARE APPROXIMATE. THE ACTUAL LOCATIONS SHALL BE CONFIRMED IN THE FIELD.

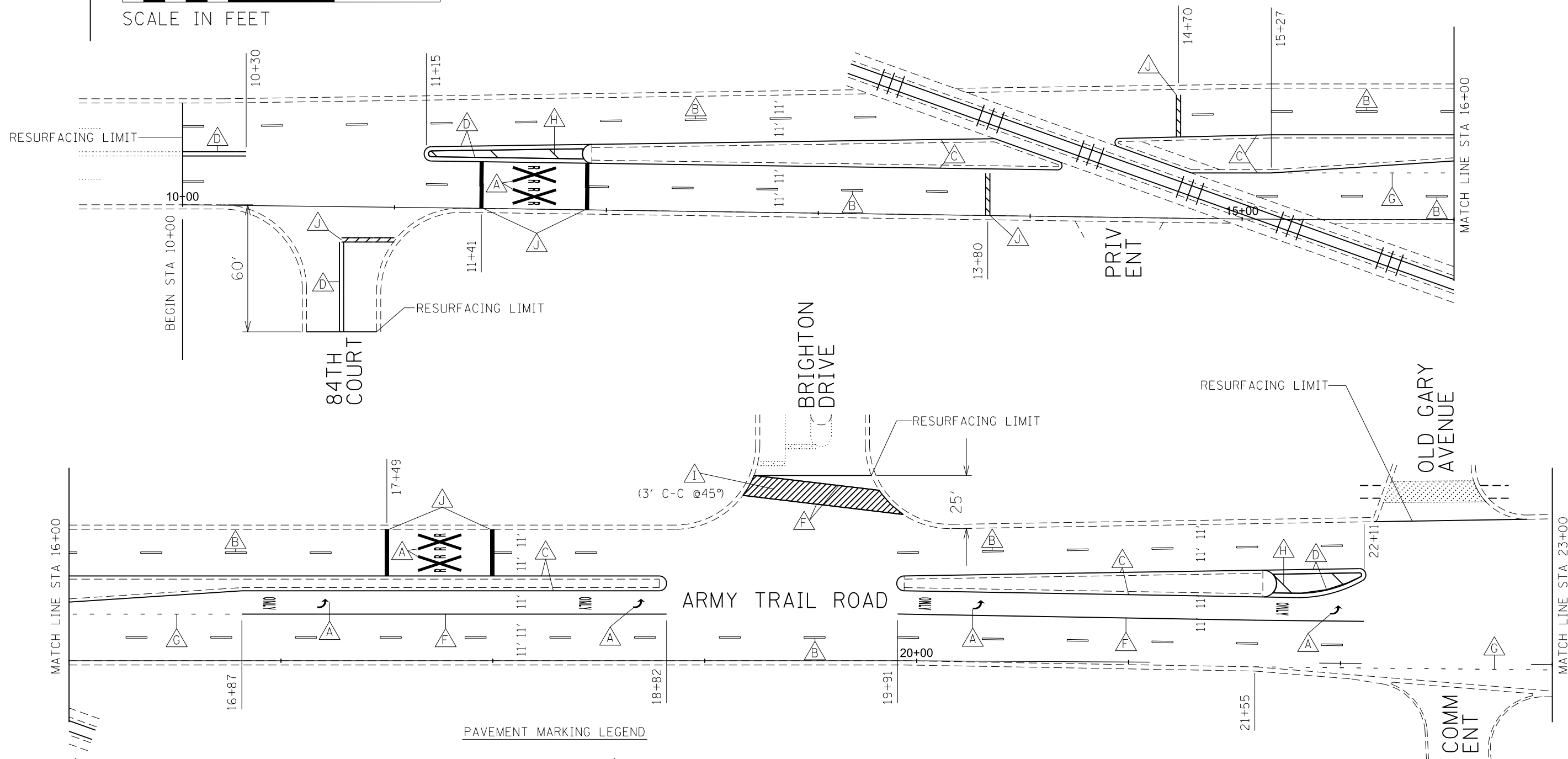

PAVEMENT MARKING LEGEND

- | | |
|---|---|
| △ A THERMOPLASTIC PAVEMENT MARKING, LETTERS AND SYMBOLS | △ G THERMOPLASTIC PAVEMENT MARKING - LINE 6", WHITE, 6' SKIP, 2' DASH |
| △ B THERMOPLASTIC PAVEMENT MARKING - LINE 4", WHITE SKIP DASH | △ H THERMOPLASTIC PAVEMENT MARKING - LINE 12", SOLID YELLOW |
| △ C THERMOPLASTIC PAVEMENT MARKING - LINE 4", SOLID YELLOW | △ I THERMOPLASTIC PAVEMENT MARKING - LINE 12", SOLID WHITE |
| △ D THERMOPLASTIC PAVEMENT MARKING - LINE 4", DOUBLE YELLOW | △ J THERMOPLASTIC PAVEMENT MARKING - LINE 24", SOLID WHITE |
| △ E THERMOPLASTIC PAVEMENT MARKING - LINE 4", SOLID WHITE | △ K THERMOPLASTIC PAVEMENT MARKING - LINE 8", SOLID WHITE |
| △ F THERMOPLASTIC PAVEMENT MARKING - LINE 6", SOLID WHITE | △ L THERMOPLASTIC PAVEMENT MARKING - LINE 4", YELLOW SKIP DASH |
| | □ PROPOSED TRAFFIC SIGNAL DETECTOR LOOP |

REVISIONS	
NAME	DATE

DUPAGE COUNTY DIVISION OF TRANSPORTATION
2022 PAVEMENT MAINTENANCE
NORTH REGION
ARMY TRAIL ROAD
PAVEMENT MARKING PLAN

DATE: 1/04/22

DRAWN BY: TH
DESIGNED BY:
CHECKED BY:

NOTES:

1.) THE LOCATIONS OF TRAFFIC SIGNAL HANDHOLES AND DETECTOR LOOPS ARE APPROXIMATE. THE ACTUAL LOCATIONS SHALL BE CONFIRMED IN THE FIELD.

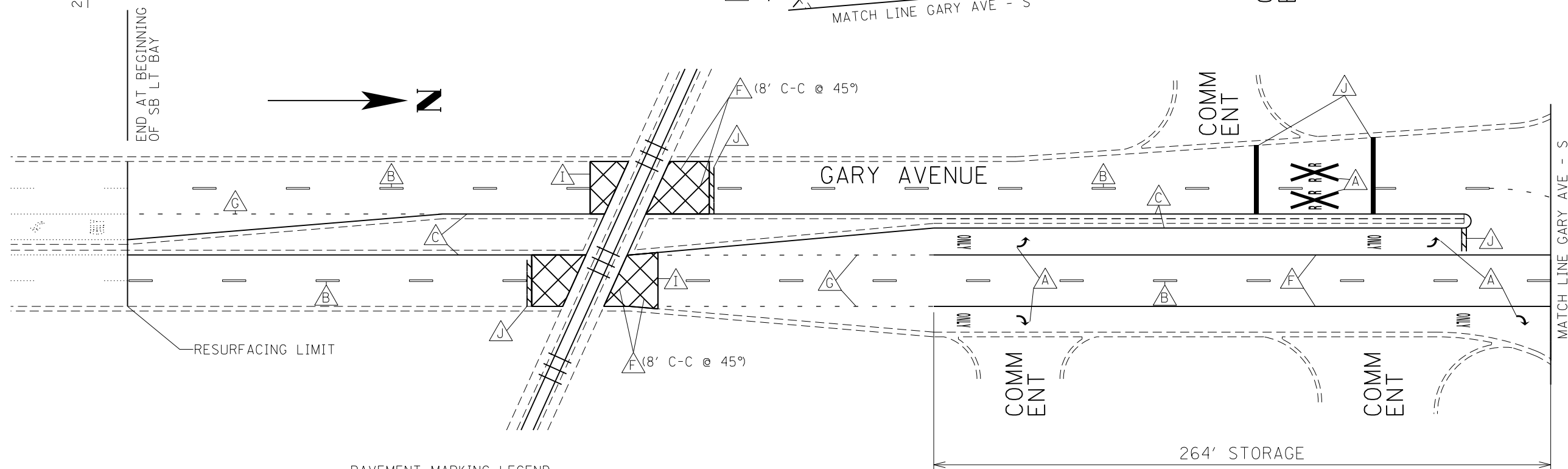
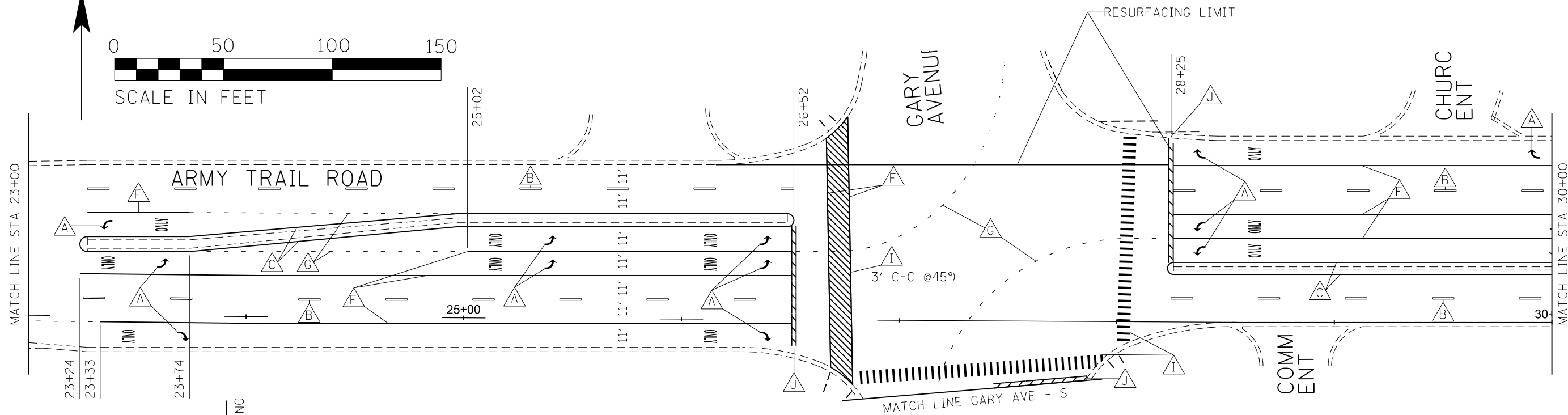

PAVEMENT MARKING LEGEND

- | | |
|---|---|
| THERMOPLASTIC PAVEMENT MARKING, LETTERS AND SYMBOLS | THERMOPLASTIC PAVEMENT MARKING - LINE 6", WHITE, 6' SKIP, 2' DASH |
| THERMOPLASTIC PAVEMENT MARKING - LINE 4", WHITE SKIP DASH | THERMOPLASTIC PAVEMENT MARKING - LINE 12", SOLID YELLOW |
| THERMOPLASTIC PAVEMENT MARKING - LINE 4", SOLID YELLOW | THERMOPLASTIC PAVEMENT MARKING - LINE 12", SOLID WHITE |
| THERMOPLASTIC PAVEMENT MARKING - LINE 4", DOUBLE YELLOW | THERMOPLASTIC PAVEMENT MARKING - LINE 24", SOLID WHITE |
| THERMOPLASTIC PAVEMENT MARKING - LINE 4", SOLID WHITE | THERMOPLASTIC PAVEMENT MARKING - LINE 8", SOLID WHITE |
| THERMOPLASTIC PAVEMENT MARKING - LINE 6", SOLID WHITE | THERMOPLASTIC PAVEMENT MARKING - LINE 4", YELLOW SKIP DASH |
| | PROPOSED TRAFFIC SIGNAL DETECTOR LOOP |

REVISIONS	
NAME	DATE

DUPAGE COUNTY DIVISION OF TRANSPORTATION
2022 PAVEMENT MAINTENANCE
NORTH REGION
ARMY TRAIL ROAD
PAVEMENT MARKING PLAN

DATE: 1/04/22

DRAWN BY: TH
DESIGNED BY:
CHECKED BY:

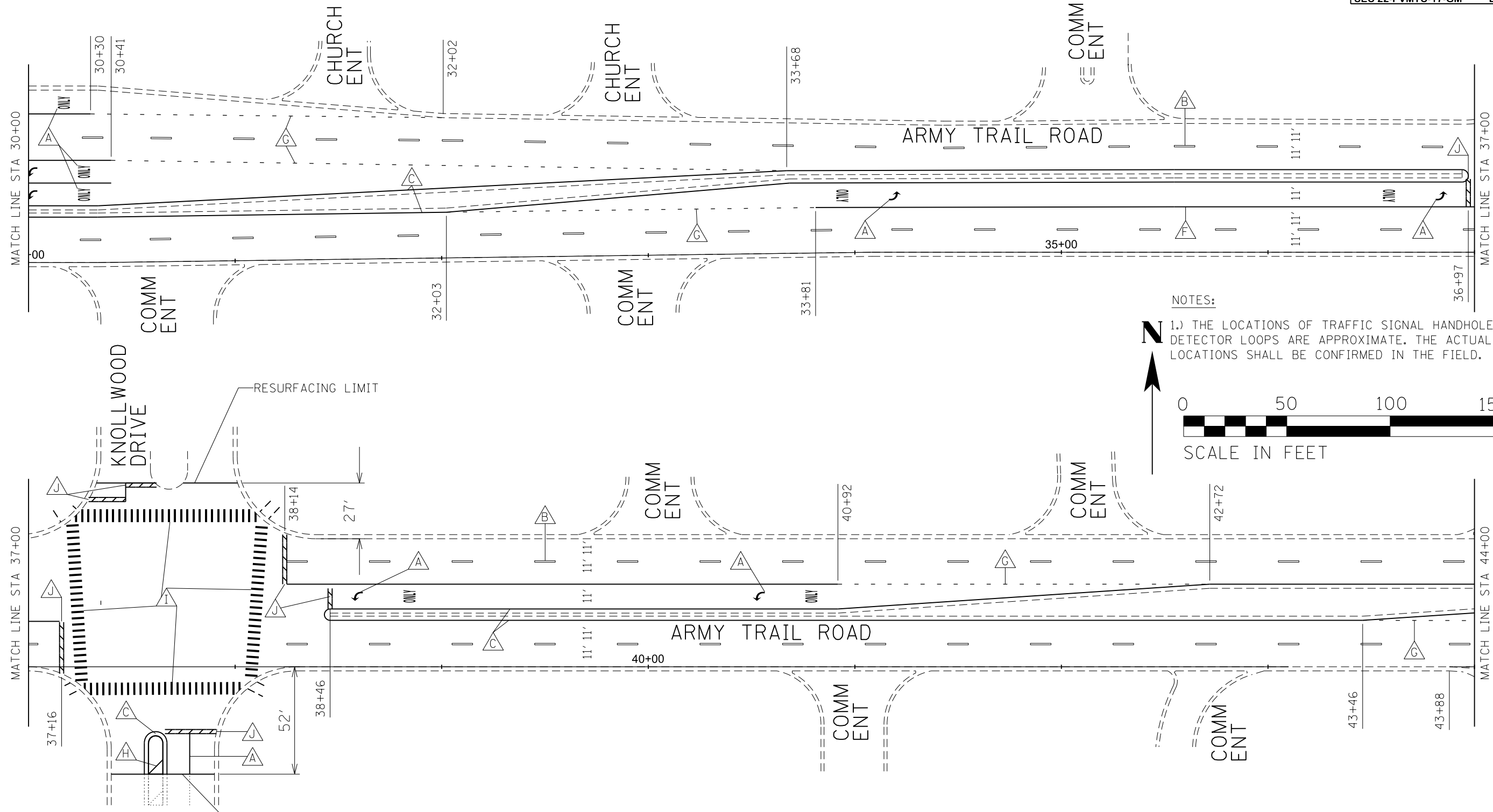

NOTES:
 1.) THE LOCATIONS OF TRAFFIC SIGNAL HANDHOLES AND DETECTOR LOOPS ARE APPROXIMATE. THE ACTUAL LOCATIONS SHALL BE CONFIRMED IN THE FIELD.

N

0 50 100 150

SCALE IN FEET

- PAVEMENT MARKING LEGEND**
- | | |
|--|--|
| A THERMOPLASTIC PAVEMENT MARKING, LETTERS AND SYMBOLS | G THERMOPLASTIC PAVEMENT MARKING - LINE 6", WHITE, 6' SKIP, 2' DASH |
| B THERMOPLASTIC PAVEMENT MARKING - LINE 4", WHITE SKIP DASH | H THERMOPLASTIC PAVEMENT MARKING - LINE 12", SOLID YELLOW |
| C THERMOPLASTIC PAVEMENT MARKING - LINE 4", SOLID YELLOW | I THERMOPLASTIC PAVEMENT MARKING - LINE 12", SOLID WHITE |
| D THERMOPLASTIC PAVEMENT MARKING - LINE 4", DOUBLE YELLOW | J THERMOPLASTIC PAVEMENT MARKING - LINE 24", SOLID WHITE |
| E THERMOPLASTIC PAVEMENT MARKING - LINE 4", SOLID WHITE | K THERMOPLASTIC PAVEMENT MARKING - LINE 8", SOLID WHITE |
| F THERMOPLASTIC PAVEMENT MARKING - LINE 6", SOLID WHITE | L THERMOPLASTIC PAVEMENT MARKING - LINE 4", YELLOW SKIP DASH |
| | □ PROPOSED TRAFFIC SIGNAL DETECTOR LOOP |

REVISIONS	
NAME	DATE

DUPAGE COUNTY DIVISION OF TRANSPORTATION
2022 PAVEMENT MAINTENANCE
 NORTH REGION
ARMY TRAIL ROAD
 PAVEMENT MARKING PLAN

DATE: 1/04/22

DRAWN BY: TH
 DESIGNED BY:
 CHECKED BY:

COUNTY HWY.	FISCAL YEAR	TOTAL SHEETS	SHEET NO.
11	2022	6	4
SEC 22-PVMT-17-GM			DUPAGE CO.

NOTES:

1.) THE LOCATIONS OF TRAFFIC SIGNAL HANDHOLES AND DETECTOR LOOPS ARE APPROXIMATE. THE ACTUAL LOCATIONS SHALL BE CONFIRMED IN THE FIELD.

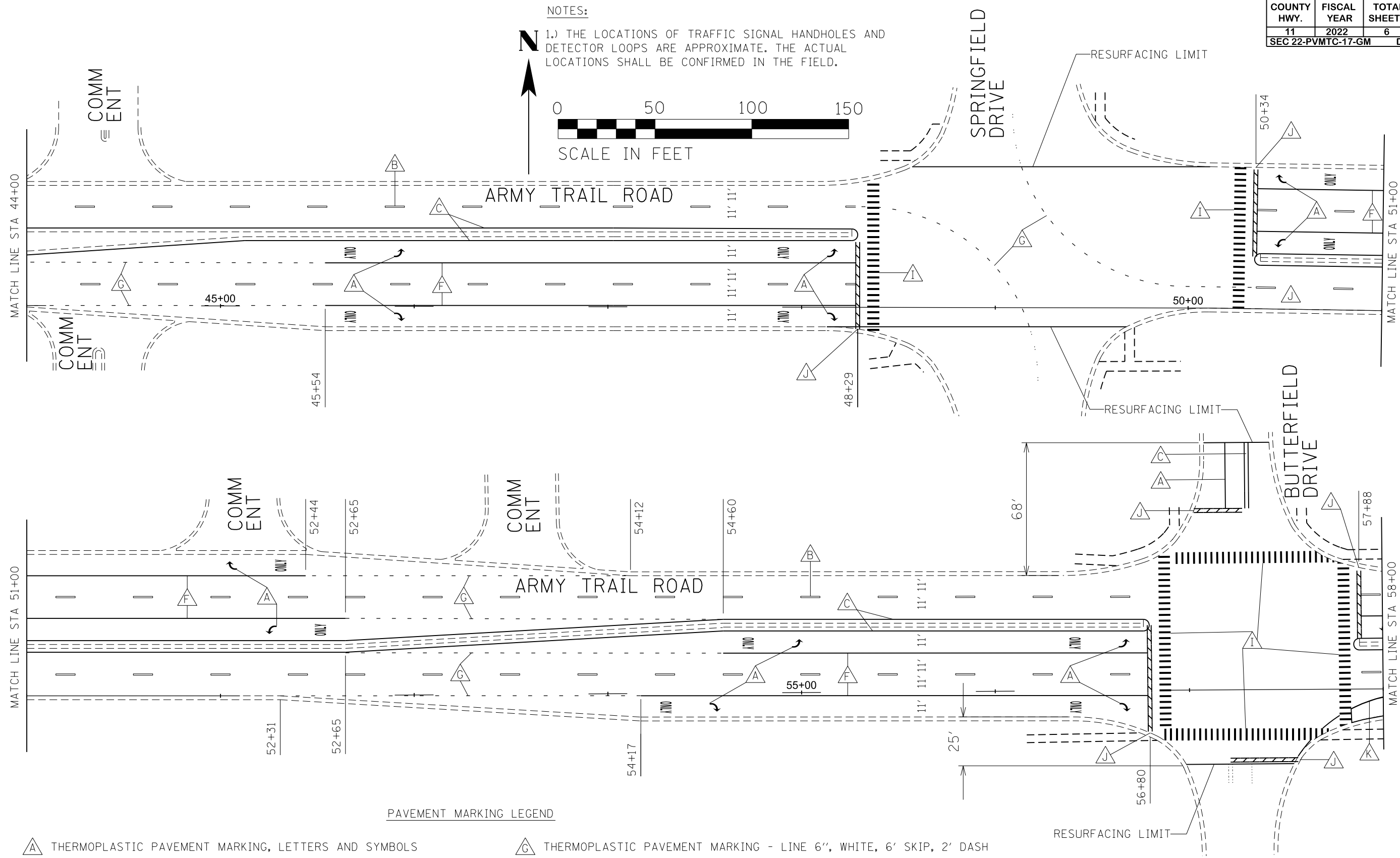
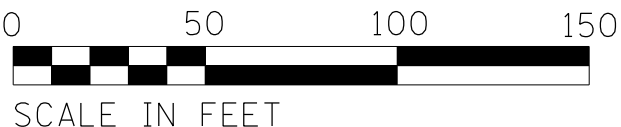

PAVEMENT MARKING LEGEND

- | | |
|--|--|
| A THERMOPLASTIC PAVEMENT MARKING, LETTERS AND SYMBOLS | G THERMOPLASTIC PAVEMENT MARKING - LINE 6", WHITE, 6' SKIP, 2' DASH |
| B THERMOPLASTIC PAVEMENT MARKING - LINE 4", WHITE SKIP DASH | H THERMOPLASTIC PAVEMENT MARKING - LINE 12", SOLID YELLOW |
| C THERMOPLASTIC PAVEMENT MARKING - LINE 4", SOLID YELLOW | I THERMOPLASTIC PAVEMENT MARKING - LINE 12", SOLID WHITE |
| D THERMOPLASTIC PAVEMENT MARKING - LINE 4", DOUBLE YELLOW | J THERMOPLASTIC PAVEMENT MARKING - LINE 24", SOLID WHITE |
| E THERMOPLASTIC PAVEMENT MARKING - LINE 4", SOLID WHITE | K THERMOPLASTIC PAVEMENT MARKING - LINE 8", SOLID WHITE |
| F THERMOPLASTIC PAVEMENT MARKING - LINE 6", SOLID WHITE | L THERMOPLASTIC PAVEMENT MARKING - LINE 4", YELLOW SKIP DASH |
| | □ . |

REVISIONS	
NAME	DATE

DUPAGE COUNTY DIVISION OF TRANSPORTATION
2022 PAVEMENT MAINTENANCE
NORTH REGION
ARMY TRAIL ROAD
PAVEMENT MARKING PLAN

DATE: 1/04/22

DRAWN BY: TH
DESIGNED BY:
CHECKED BY:

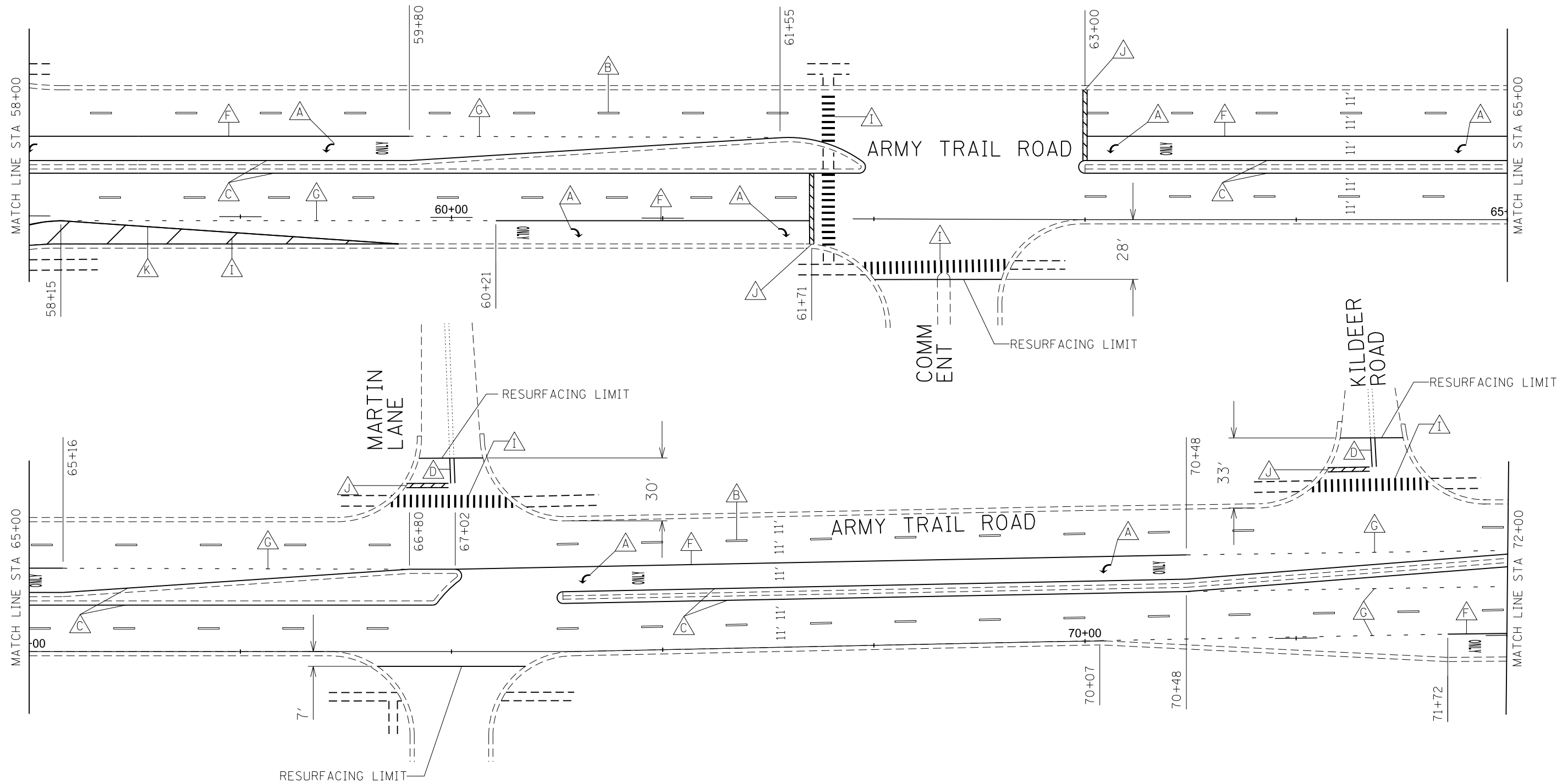

PAVEMENT MARKING LEGEND

- | | |
|---|---|
| △ A THERMOPLASTIC PAVEMENT MARKING, LETTERS AND SYMBOLS | △ G THERMOPLASTIC PAVEMENT MARKING - LINE 6", WHITE, 6' SKIP, 2' DASH |
| △ B THERMOPLASTIC PAVEMENT MARKING - LINE 4", WHITE SKIP DASH | △ H THERMOPLASTIC PAVEMENT MARKING - LINE 12", SOLID YELLOW |
| △ C THERMOPLASTIC PAVEMENT MARKING - LINE 4", SOLID YELLOW | △ I THERMOPLASTIC PAVEMENT MARKING - LINE 12", SOLID WHITE |
| △ D THERMOPLASTIC PAVEMENT MARKING - LINE 4", DOUBLE YELLOW | △ J THERMOPLASTIC PAVEMENT MARKING - LINE 24", SOLID WHITE |
| △ E THERMOPLASTIC PAVEMENT MARKING - LINE 4", SOLID WHITE | △ K THERMOPLASTIC PAVEMENT MARKING - LINE 8", SOLID WHITE |
| △ F THERMOPLASTIC PAVEMENT MARKING - LINE 6", SOLID WHITE | △ L THERMOPLASTIC PAVEMENT MARKING - LINE 4", YELLOW SKIP DASH |
| | □ PROPOSED TRAFFIC SIGNAL DETECTOR LOOP |

REVISIONS	
NAME	DATE

DUPAGE COUNTY DIVISION OF TRANSPORTATION
2022 PAVEMENT MAINTENANCE
NORTH REGION
ARMY TRAIL ROAD
PAVEMENT MARKING PLAN

DATE: 1/04/22

DRAWN BY: TH
DESIGNED BY:
CHECKED BY:

NOTES:

1.) THE LOCATIONS OF TRAFFIC SIGNAL HANDHOLES AND DETECTOR LOOPS ARE APPROXIMATE. THE ACTUAL LOCATIONS SHALL BE CONFIRMED IN THE FIELD.

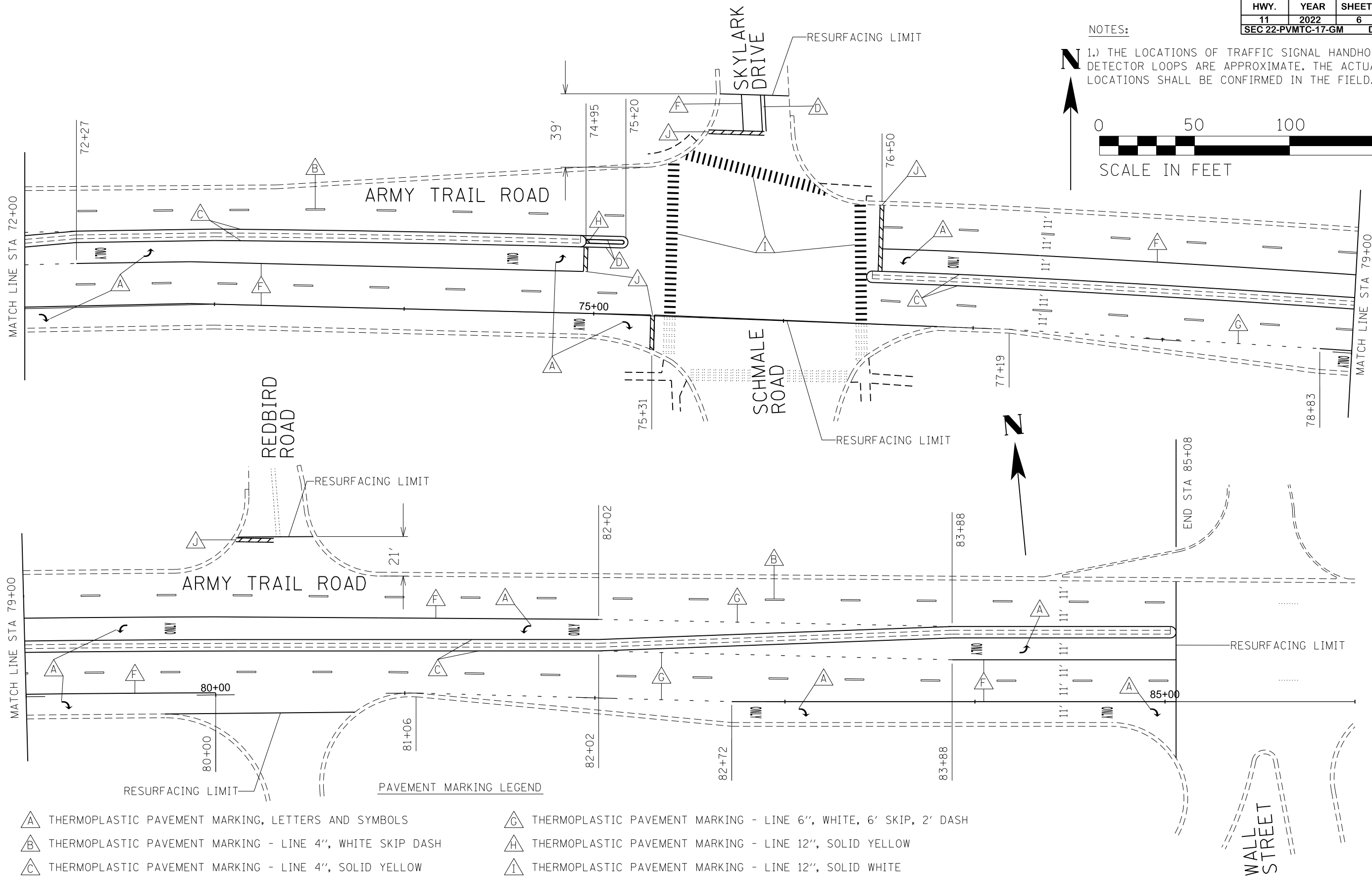

- | | |
|---|---|
| △ A THERMOPLASTIC PAVEMENT MARKING, LETTERS AND SYMBOLS | △ G THERMOPLASTIC PAVEMENT MARKING - LINE 6", WHITE, 6' SKIP, 2' DASH |
| △ B THERMOPLASTIC PAVEMENT MARKING - LINE 4", WHITE SKIP DASH | △ H THERMOPLASTIC PAVEMENT MARKING - LINE 12", SOLID YELLOW |
| △ C THERMOPLASTIC PAVEMENT MARKING - LINE 4", SOLID YELLOW | △ I THERMOPLASTIC PAVEMENT MARKING - LINE 12", SOLID WHITE |
| △ D THERMOPLASTIC PAVEMENT MARKING - LINE 4", DOUBLE YELLOW | △ J THERMOPLASTIC PAVEMENT MARKING - LINE 24", SOLID WHITE |
| △ E THERMOPLASTIC PAVEMENT MARKING - LINE 4", SOLID WHITE | △ K THERMOPLASTIC PAVEMENT MARKING - LINE 8", SOLID WHITE |
| △ F THERMOPLASTIC PAVEMENT MARKING - LINE 6", SOLID WHITE | △ L THERMOPLASTIC PAVEMENT MARKING - LINE 4", YELLOW SKIP DASH |
| | □ PROPOSED TRAFFIC SIGNAL DETECTOR LOOP |

PAVEMENT MARKING LEGEND

REVISIONS	
NAME	DATE

DUPAGE COUNTY DIVISION OF TRANSPORTATION
2022 PAVEMENT MAINTENANCE
NORTH REGION
ARMY TRAIL ROAD
PAVEMENT MARKING PLAN

DATE: 1/04/22

DRAWN BY: TH
DESIGNED BY:
CHECKED BY:



CONSTRUCTION NOTES

1. The project will begin 275 ft east of County Farm Road and terminate 320 ft west of Western Avenue, omitting from 360 ft west of Schmale Road to 315 ft east of Schmale Road, and will include all side streets up to the county right of way as shown on the pavement marking plans and as determined by the engineer.
2. The proposed improvements include milling – 2 ½ ” of the existing HMA surface course, Class D pavement patching, curb and gutter removal and replacement and sidewalk removal and replacement as determined by the Engineer, detector loop replacement, ¾” polymerized leveling binder (machine method), IL – 4.75, N50, longitudinal joint sealant, 1 ¾” polymerized HMA surface course Mix E N70, pavement markings, recessed pavement markers, and storm sewer.
3. Longitudinal joint sealant shall be placed prior to the placement of the HMA surface course. It shall be placed at the lane line, center line, and turn lane paving joints, except where the pavement is less than 48 Ft wide it shall only be placed at the centerline. It shall also be placed at the edge of pavement across side streets.
4. The traffic signals located at the following intersections are maintained by the DuPage DOT:

Geneva Road / County Farm Road
Geneva Road / Pleasant Hill Road
Geneva Road / Gary Avenue
Geneva Road / Morse Street
Geneva Road / Geneva Crossing Shopping Center
Geneva Road / President Street
Geneva Road / Bloomingdale Road
Geneva Road / Kenilworth Avenue

The Contractor shall notify the DuPage County Division of Transportation 7 days prior to the removal of any loop detection.

5. A contract has been executed for the replacement of the traffic signal at the intersection of Geneva Rd and Gary Ave. The Contractor shall coordinate their work and traffic control with the Contractor for the traffic signal project.

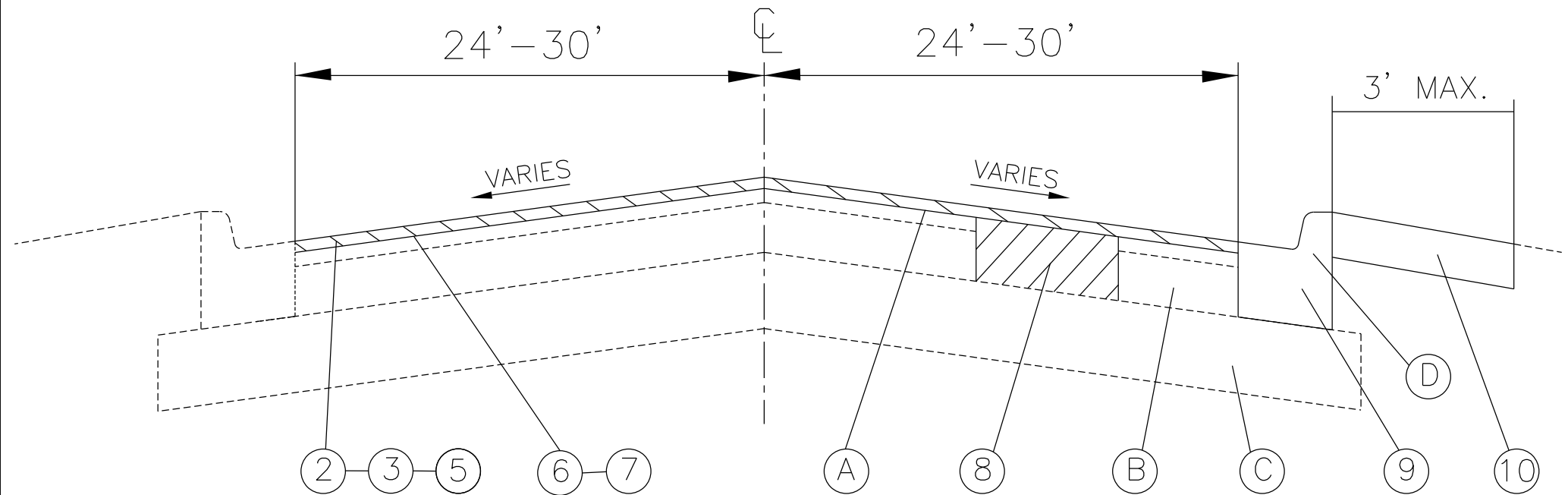

CH 21 / GENEVA ROAD
 COUNTY FARM RD TO GARY AVE
 TYPICAL SECTION

- ① HMA SURFACE REMOVAL, 2 $\frac{1}{4}$ "
- ② HMA SURFACE REMOVAL, 2 $\frac{1}{2}$ "
- ③ POLY LEVEL BINDER, HMA, IL 4.75 N50 3 $\frac{3}{4}$ "
- ④ HMA SURFACE COURSE MIX D, N70, 1 $\frac{1}{2}$ "
- ⑤ POLY HMA SURFACE COURSE MIX E, N70, 1 $\frac{3}{4}$ "
- ⑥ BITUMINOUS MATERIALS (TACK COAT)
- ⑦ AGGREGATE FOR COVERING TACK COAT (AS NEEDED)
- ⑧ CLASS D PATCH, 12" (AS DIRECTED BY THE ENGINEER)
- ⑨ COMBINATION CONCRETE CURB & GUTTER REMOVAL AND REPLACEMENT (AS DIRECTED BY THE ENGINEER)
- ⑩ CLASS 2A SEED AND BLANKET MIN. 6" TOPSOIL

- Ⓐ EXISTING BITUMINOUS BINDER AND SURFACE (3.5")
- Ⓑ EXISTING BITUMINOUS BASE COURSE - 11"
- Ⓒ EXISTING AGGREGATE SUBGRADE
- Ⓓ EXISTING COMBINATION CONCRETE CURB AND GUTTER, TYPE B-6.18

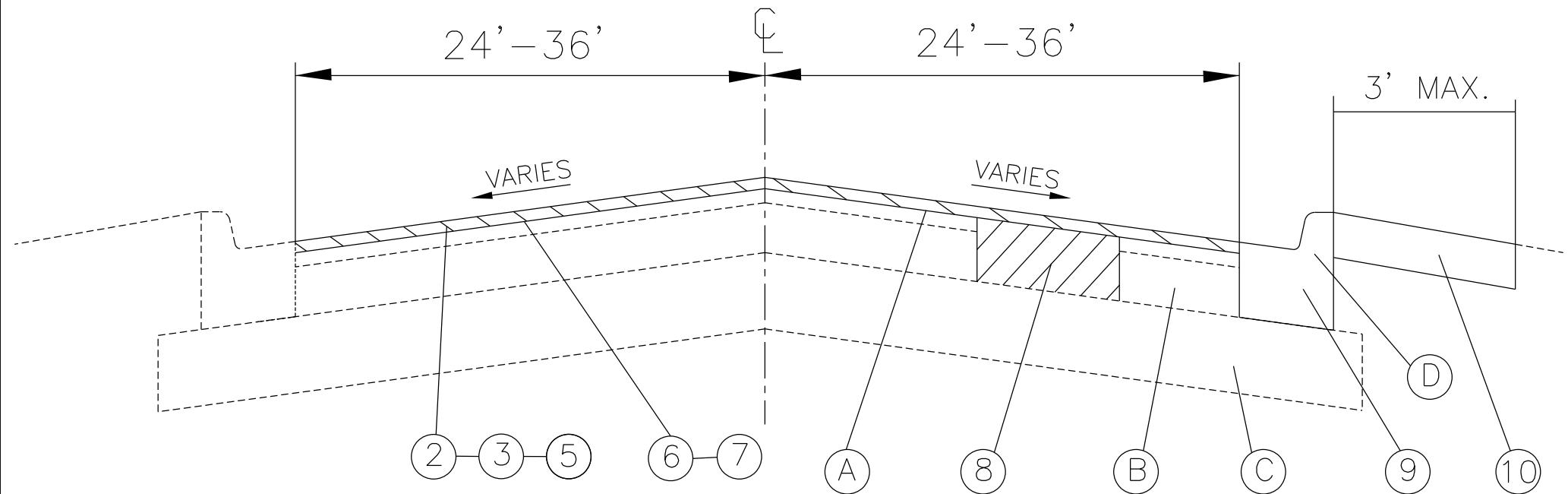

CH 21 / GENEVA ROAD
 GARY AVE TO WESTERN AVE
 TYPICAL SECTION

- ① HMA SURFACE REMOVAL, 2¼"
- ② HMA SURFACE REMOVAL, 2½"
- ③ POLY LEVEL BINDER, HMA, IL 4.75 N50 ¾"
- ④ HMA SURFACE COURSE MIX D, N70, 1½"
- ⑤ POLY HMA SURFACE COURSE MIX E, N70, 1¾"
- ⑥ BITUMINOUS MATERIALS (TACK COAT)
- ⑦ AGGREGATE FOR COVERING TACK COAT (AS NEEDED)
- ⑧ CLASS D PATCH, 10" (AS DIRECTED BY THE ENGINEER)
- ⑨ COMBINATION CONCRETE CURB & GUTTER REMOVAL AND REPLACEMENT (AS DIRECTED BY THE ENGINEER)
- ⑩ CLASS 2A SEED AND BLANKET MIN. 6" TOPSOIL

- A EXISTING BITUMINOUS BINDER AND SURFACE (3")
- B EXISTING BITUMINOUS BASE COURSE -9"
- C EXISTING AGGREGATE SUBGRADE
- D EXISTING COMBINATION CONCRETE CURB AND GUTTER, TYPE B-6.18

DRAINAGE SCHEDULE - GENEVA ROAD

STATION	LOCATION	TYPE	STATION	LOCATION	TYPE
10+85	R	ADJUST	211+91	R	NEW INLET
12+89	R	ADJUST	219+33	R	RECONSTRUCT
17+30	R	ADJUST	219+67	R	ADJUST
24+42	R	ADJUST	12+89	L	ADJUST
35+04	R	PATCH	17+33	L	ADJUST
54+09	R	ADJUST	22+70	L	ADJUST W/ NEW TY. 23
61+73	R	ADJUST	26+48	L	ADJUST
63+22	R	ADJUST	31+61	L	ADJUST
69+33	R	ADJUST	34+47	L	ADJUST
79+33	R	ADJUST	38+06	L	ADJUST
81+84	R	ADJUST	49+10	L	ADJUST W/ NEW TY. 23
82+35	R	RECONSTRUCT	59+19	L	ADJUST
92+40	R	ADJUST	61+73	L	ADJUST
94+73	R	ADJUST	63+22	L	ADJUST
96+44	R	PATCH	75+32	L	ADJUST
109+52	R	PATCH	79+33	L	ADJUST
113+52	R	ADJUST	84+33	L	ADJUST
117+57	R	ADJUST	92+40	L	ADJUST
121+63	R	PATCH	98+95	L	PATCH
132+72	R	PATCH	121+63	L	ADJUST
136+24	R	NEW INLET	122+49	L	ADJUST
136+73	R	ADJUST	124+43	L	ADJUST
149+90	R	NEW INLET	136+28	L	RECONSTRUCT
155+95	R	ADJUST	153+05	L	PATCH
159+97	R	PATCH	155+95	L	NEW INLET
164+00	R	ADJUST	168+00	L	ADJUST
168+00	R	RECONSTRUCT	169+98	L	PATCH
170+00	R	ADJUST	172+00	L	PATCH
172+00	R	RECONSTRUCT	175+00	L	ADJUST
175+03	R	NEW INLET	185+11	L	PATCH
178+21	R	NEW INLET	199+00	L	PATCH
185+11	R	ADJUST	208+25	L	PATCH
188+11	R	PATCH	NB GARY - S. OF GENEVA	R	NEW INLET
193+18	R	PATCH	NB GARY - S. OF GENEVA	R	NEW INLET
200+25	R	NEW INLET	SE CORNER GARY AVE		ADJUST
203+20	R	NEW INLET	NE CORNER GARY AVE		PATCH
206+25	R	NEW INLET	NB GARY - N. OF GENVA	R	ADJUST
208+26	R	NEW INLET			

COUNTY HWY.	FISCAL YEAR	TOTAL SHEETS	SHEET NO.
21	2022	17	1
SEC 22-PVMTC-17-GM		DUPAGE CO.	

NOTES:

1.) THE LOCATIONS OF TRAFFIC SIGNAL HANDHOLES AND DETECTOR LOOPS ARE APPROXIMATE. THE ACTUAL LOCATIONS SHALL BE CONFIRMED IN THE FIELD.

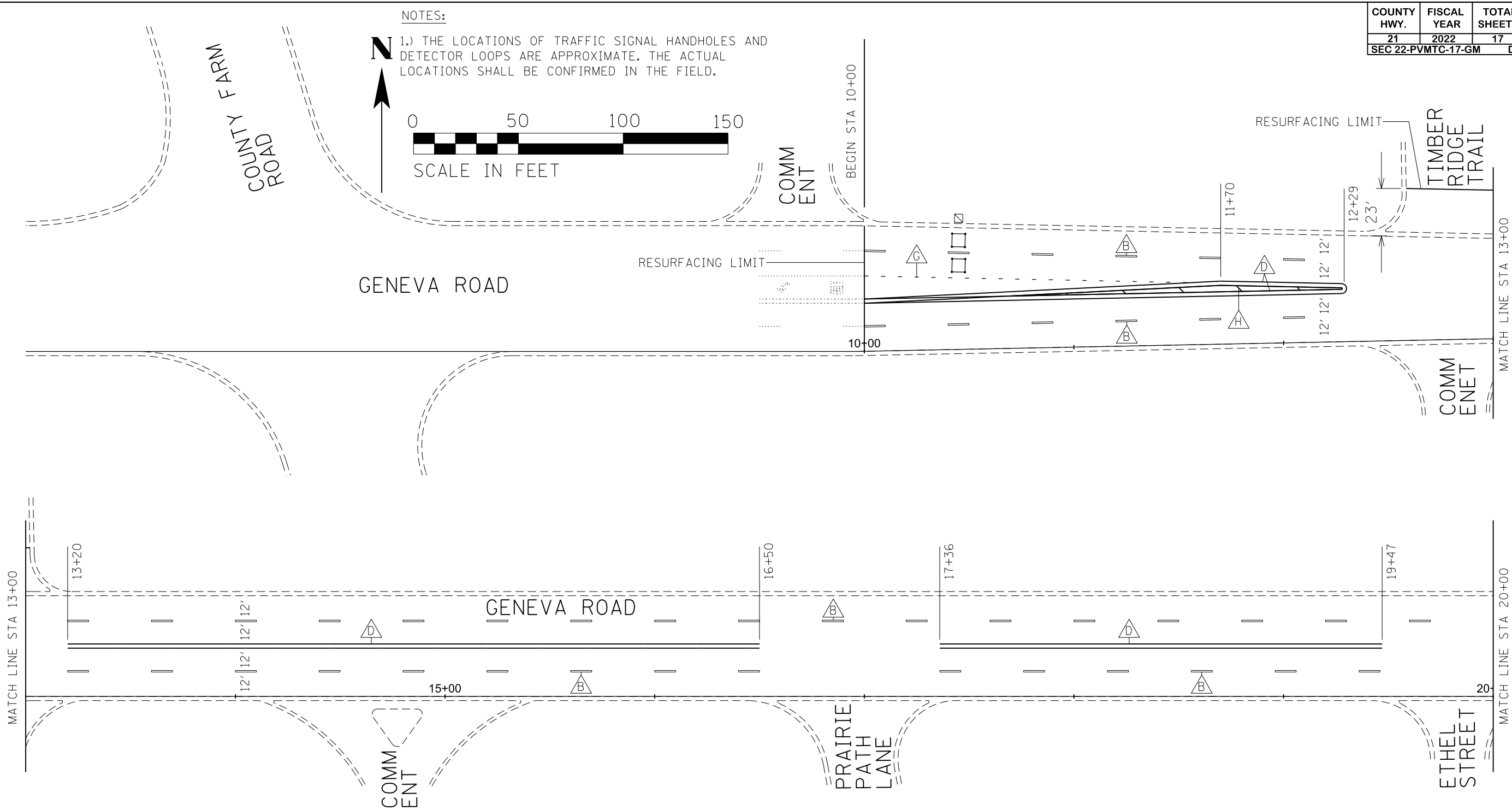

PAVEMENT MARKING LEGEND

- | | |
|---|---|
| THERMOPLASTIC PAVEMENT MARKING, LETTERS AND SYMBOLS | THERMOPLASTIC PAVEMENT MARKING - LINE 6", WHITE, 6' SKIP, 2' DASH |
| THERMOPLASTIC PAVEMENT MARKING - LINE 4", WHITE SKIP DASH | THERMOPLASTIC PAVEMENT MARKING - LINE 12", SOLID YELLOW |
| THERMOPLASTIC PAVEMENT MARKING - LINE 4", SOLID YELLOW | THERMOPLASTIC PAVEMENT MARKING - LINE 12", SOLID WHITE |
| THERMOPLASTIC PAVEMENT MARKING - LINE 4", DOUBLE YELLOW | THERMOPLASTIC PAVEMENT MARKING - LINE 24", SOLID WHITE |
| THERMOPLASTIC PAVEMENT MARKING - LINE 4", SOLID WHITE | THERMOPLASTIC PAVEMENT MARKING - LINE 8", SOLID WHITE |
| THERMOPLASTIC PAVEMENT MARKING - LINE 6", SOLID WHITE | THERMOPLASTIC PAVEMENT MARKING - LINE 4", YELLOW SKIP DASH |
| | PROPOSED TRAFFIC SIGNAL DETECTOR LOOP |

REVISIONS	
NAME	DATE

DUPAGE COUNTY DIVISION OF TRANSPORTATION
2022 PAVEMENT MAINTENANCE
 NORTH REGION
 GENEVA ROAD
 PAVEMENT MARKING PLAN

DATE: 1/04/22

DRAWN BY: TH
 DESIGNED BY:
 CHECKED BY:

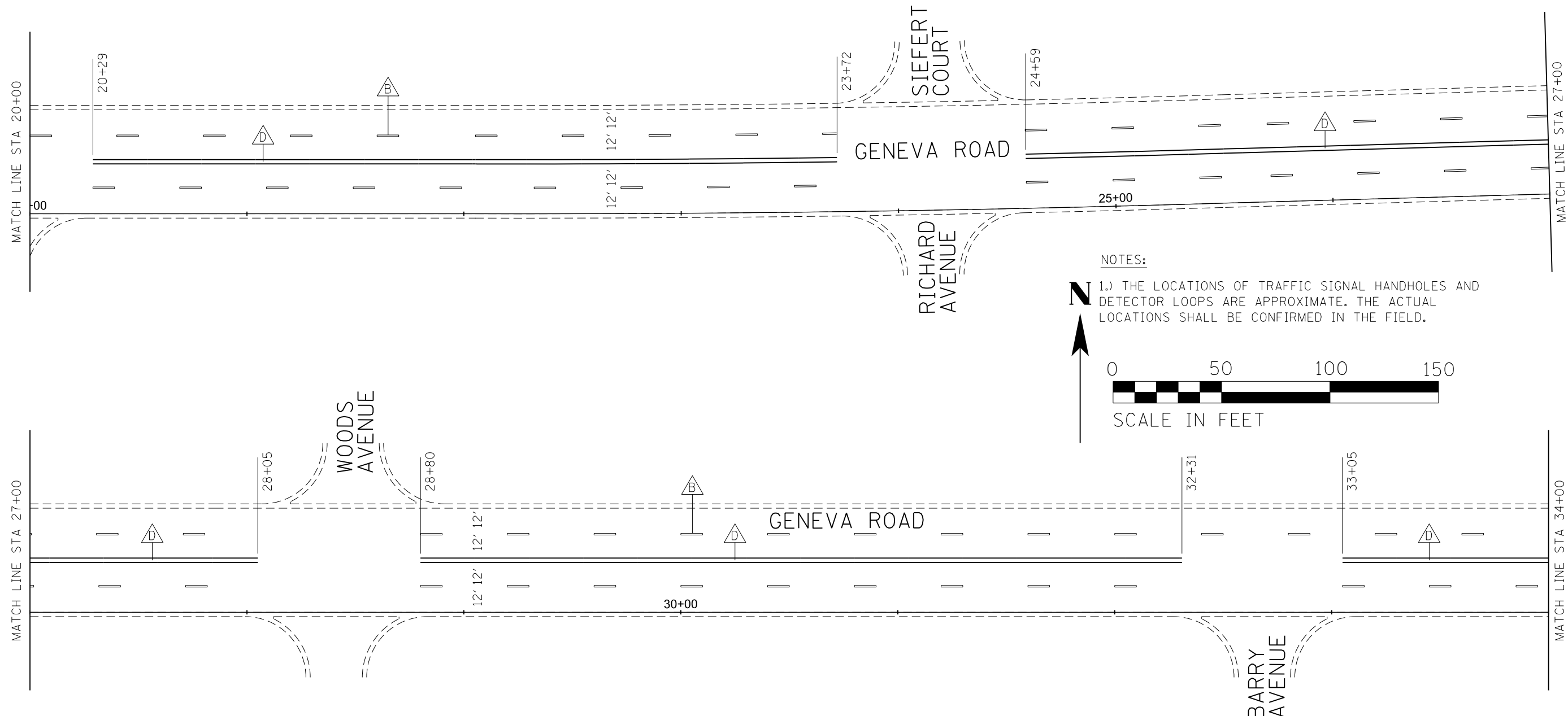

NOTES:
 1.) THE LOCATIONS OF TRAFFIC SIGNAL HANDHOLES AND DETECTOR LOOPS ARE APPROXIMATE. THE ACTUAL LOCATIONS SHALL BE CONFIRMED IN THE FIELD.

SCALE IN FEET

PAVEMENT MARKING LEGEND

- | | |
|---|---|
| THERMOPLASTIC PAVEMENT MARKING, LETTERS AND SYMBOLS | THERMOPLASTIC PAVEMENT MARKING - LINE 6", WHITE, 6' SKIP, 2' DASH |
| THERMOPLASTIC PAVEMENT MARKING - LINE 4", WHITE SKIP DASH | THERMOPLASTIC PAVEMENT MARKING - LINE 12", SOLID YELLOW |
| THERMOPLASTIC PAVEMENT MARKING - LINE 4", SOLID YELLOW | THERMOPLASTIC PAVEMENT MARKING - LINE 12", SOLID WHITE |
| THERMOPLASTIC PAVEMENT MARKING - LINE 4", DOUBLE YELLOW | THERMOPLASTIC PAVEMENT MARKING - LINE 24", SOLID WHITE |
| THERMOPLASTIC PAVEMENT MARKING - LINE 4", SOLID WHITE | THERMOPLASTIC PAVEMENT MARKING - LINE 8", SOLID WHITE |
| THERMOPLASTIC PAVEMENT MARKING - LINE 6", SOLID WHITE | THERMOPLASTIC PAVEMENT MARKING - LINE 4", YELLOW SKIP DASH |
| | PROPOSED TRAFFIC SIGNAL DETECTOR LOOP |

REVISIONS	
NAME	DATE

DUPAGE COUNTY DIVISION OF TRANSPORTATION
2022 PAVEMENT MAINTENANCE
NORTH REGION
GENEVA ROAD
PAVEMENT MARKING PLAN

DATE: 1/04/22

DRAWN BY: TH
 DESIGNED BY:
 CHECKED BY:

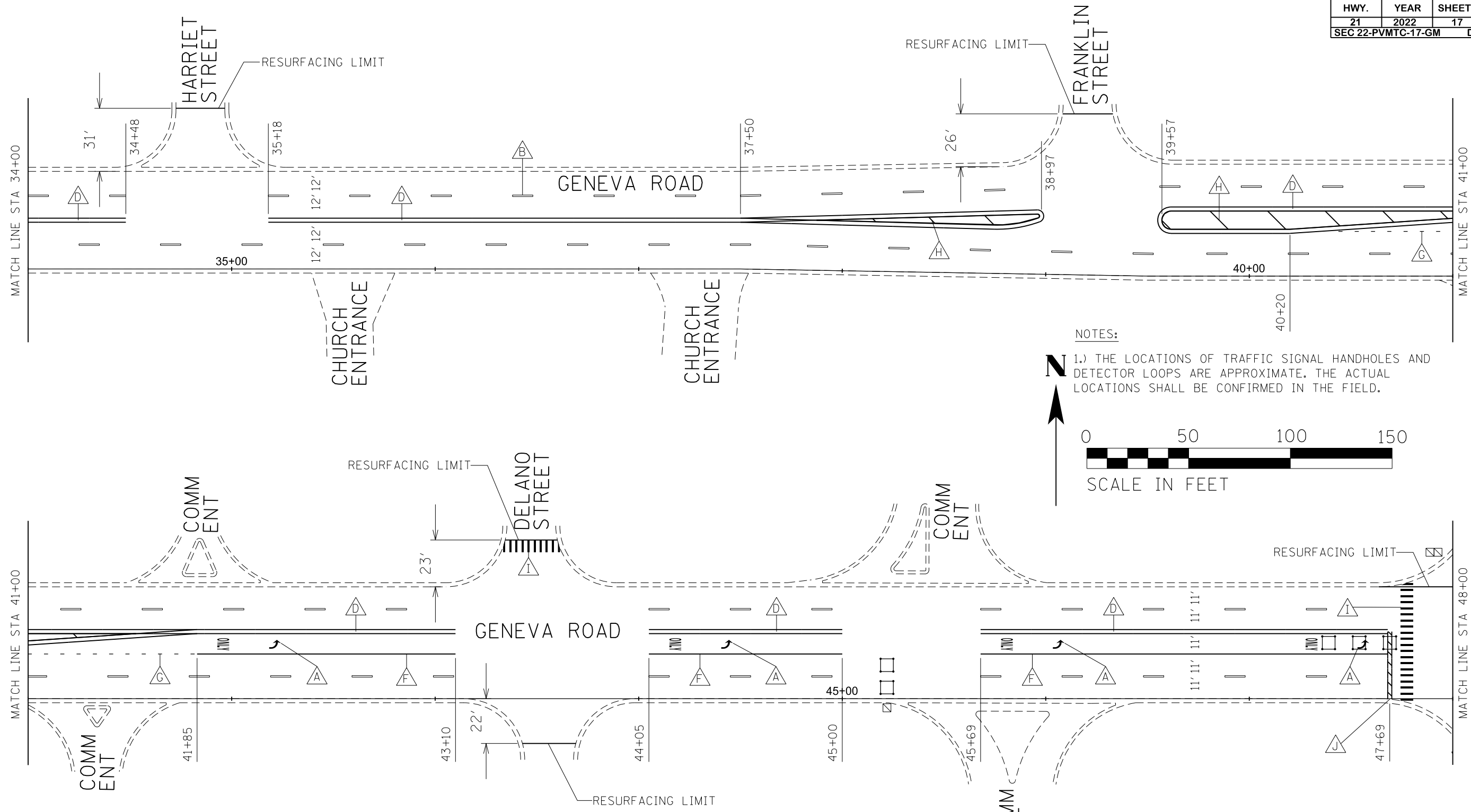

NOTES:

1.) THE LOCATIONS OF TRAFFIC SIGNAL HANDHOLES AND DETECTOR LOOPS ARE APPROXIMATE. THE ACTUAL LOCATIONS SHALL BE CONFIRMED IN THE FIELD.



PAVEMENT MARKING LEGEND

- | | |
|---|---|
| △ A THERMOPLASTIC PAVEMENT MARKING, LETTERS AND SYMBOLS | △ G THERMOPLASTIC PAVEMENT MARKING - LINE 6", WHITE, 6' SKIP, 2' DASH |
| △ B THERMOPLASTIC PAVEMENT MARKING - LINE 4", WHITE SKIP DASH | △ H THERMOPLASTIC PAVEMENT MARKING - LINE 12", SOLID YELLOW |
| △ C THERMOPLASTIC PAVEMENT MARKING - LINE 4", SOLID YELLOW | △ I THERMOPLASTIC PAVEMENT MARKING - LINE 12", SOLID WHITE |
| △ D THERMOPLASTIC PAVEMENT MARKING - LINE 4", DOUBLE YELLOW | △ J THERMOPLASTIC PAVEMENT MARKING - LINE 24", SOLID WHITE |
| △ E THERMOPLASTIC PAVEMENT MARKING - LINE 4", SOLID WHITE | △ K THERMOPLASTIC PAVEMENT MARKING - LINE 8", SOLID WHITE |
| △ F THERMOPLASTIC PAVEMENT MARKING - LINE 6", SOLID WHITE | △ L THERMOPLASTIC PAVEMENT MARKING - LINE 4", YELLOW SKIP DASH |
| | □ PROPOSED TRAFFIC SIGNAL DETECTOR LOOP |

REVISIONS	
NAME	DATE

DUPAGE COUNTY DIVISION OF TRANSPORTATION
2022 PAVEMENT MAINTENANCE
NORTH REGION
GENEVA ROAD
PAVEMENT MARKING PLAN

DATE: 1/04/22

DRAWN BY: TH
DESIGNED BY:
CHECKED BY:

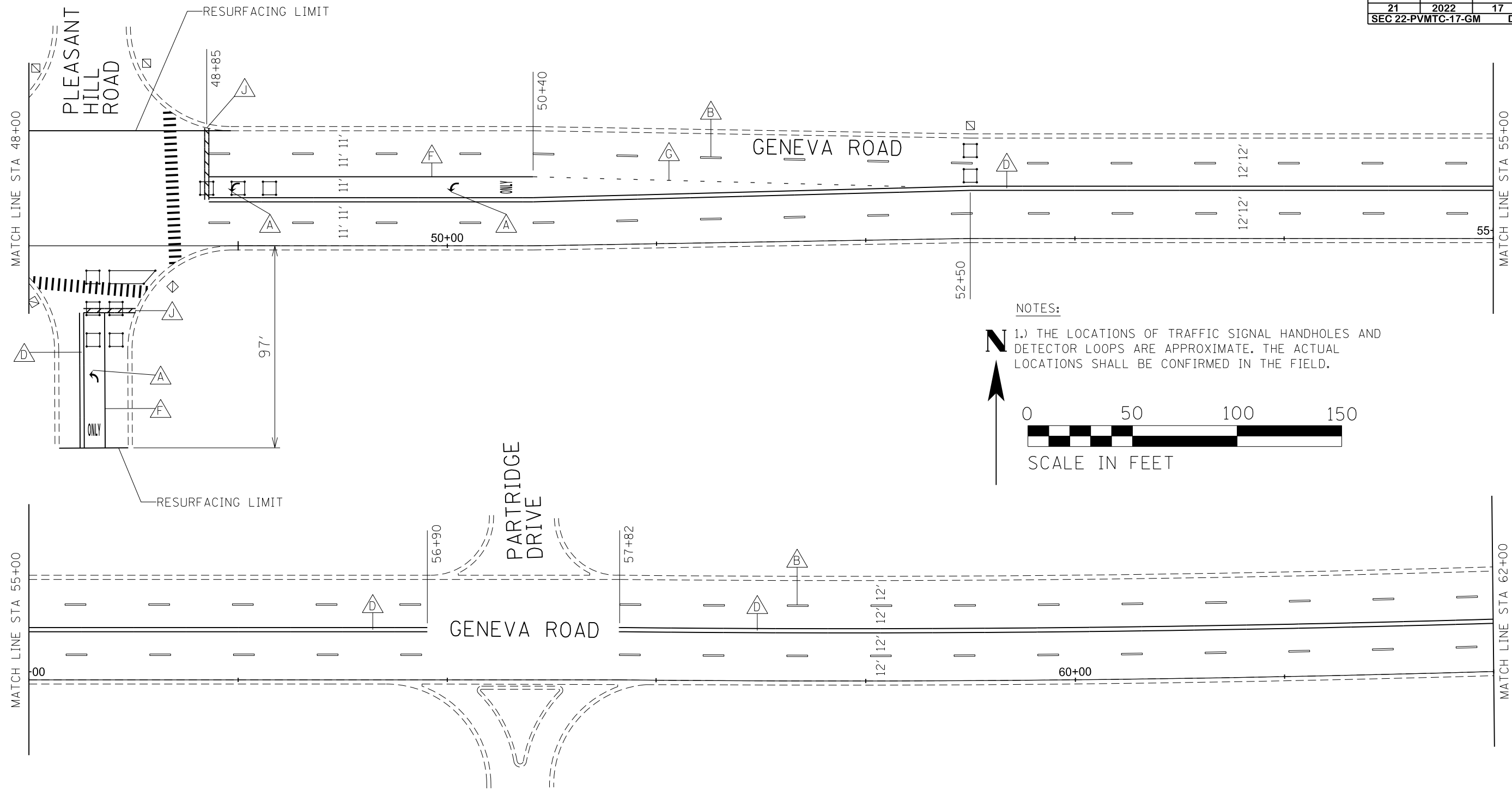

NOTES:

1.) THE LOCATIONS OF TRAFFIC SIGNAL HANDHOLES AND DETECTOR LOOPS ARE APPROXIMATE. THE ACTUAL LOCATIONS SHALL BE CONFIRMED IN THE FIELD.



SCALE IN FEET

PAVEMENT MARKING LEGEND

- | | |
|---|---|
| △ A THERMOPLASTIC PAVEMENT MARKING, LETTERS AND SYMBOLS | △ G THERMOPLASTIC PAVEMENT MARKING - LINE 6", WHITE, 6' SKIP, 2' DASH |
| △ B THERMOPLASTIC PAVEMENT MARKING - LINE 4", WHITE SKIP DASH | △ H THERMOPLASTIC PAVEMENT MARKING - LINE 12", SOLID YELLOW |
| △ C THERMOPLASTIC PAVEMENT MARKING - LINE 4", SOLID YELLOW | △ I THERMOPLASTIC PAVEMENT MARKING - LINE 12", SOLID WHITE |
| △ D THERMOPLASTIC PAVEMENT MARKING - LINE 4", DOUBLE YELLOW | △ J THERMOPLASTIC PAVEMENT MARKING - LINE 24", SOLID WHITE |
| △ E THERMOPLASTIC PAVEMENT MARKING - LINE 4", SOLID WHITE | △ K THERMOPLASTIC PAVEMENT MARKING - LINE 8", SOLID WHITE |
| △ F THERMOPLASTIC PAVEMENT MARKING - LINE 6", SOLID WHITE | △ L THERMOPLASTIC PAVEMENT MARKING - LINE 4", YELLOW SKIP DASH |
| | □ PROPOSED TRAFFIC SIGNAL DETECTOR LOOP |

REVISIONS	
NAME	DATE

DUPAGE COUNTY DIVISION OF TRANSPORTATION
2022 PAVEMENT MAINTENANCE
NORTH REGION
GENEVA ROAD
PAVEMENT MARKING PLAN

DATE: 1/04/22

DRAWN BY: TH
DESIGNED BY:
CHECKED BY:

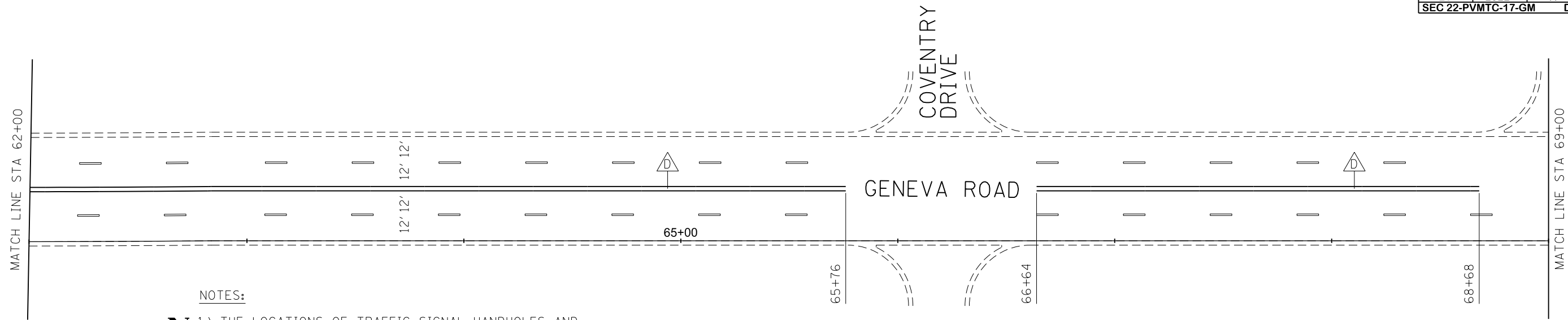

NOTES:

1.) THE LOCATIONS OF TRAFFIC SIGNAL HANDHOLES AND DETECTOR LOOPS ARE APPROXIMATE. THE ACTUAL LOCATIONS SHALL BE CONFIRMED IN THE FIELD.

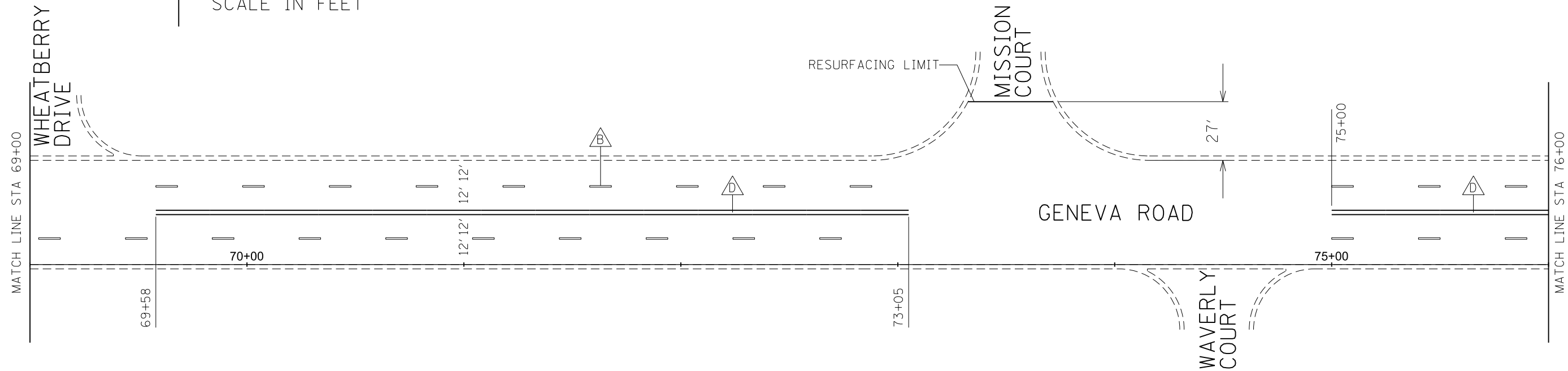

PAVEMENT MARKING LEGEND

- | | |
|---|---|
| △ A THERMOPLASTIC PAVEMENT MARKING, LETTERS AND SYMBOLS | △ G THERMOPLASTIC PAVEMENT MARKING - LINE 6", WHITE, 6' SKIP, 2' DASH |
| △ B THERMOPLASTIC PAVEMENT MARKING - LINE 4", WHITE SKIP DASH | △ H THERMOPLASTIC PAVEMENT MARKING - LINE 12", SOLID YELLOW |
| △ C THERMOPLASTIC PAVEMENT MARKING - LINE 4", SOLID YELLOW | △ I THERMOPLASTIC PAVEMENT MARKING - LINE 12", SOLID WHITE |
| △ D THERMOPLASTIC PAVEMENT MARKING - LINE 4", DOUBLE YELLOW | △ J THERMOPLASTIC PAVEMENT MARKING - LINE 24", SOLID WHITE |
| △ E THERMOPLASTIC PAVEMENT MARKING - LINE 4", SOLID WHITE | △ K THERMOPLASTIC PAVEMENT MARKING - LINE 8", SOLID WHITE |
| △ F THERMOPLASTIC PAVEMENT MARKING - LINE 6", SOLID WHITE | △ L THERMOPLASTIC PAVEMENT MARKING - LINE 4", YELLOW SKIP DASH |
| | □ PROPOSED TRAFFIC SIGNAL DETECTOR LOOP |

REVISIONS	
NAME	DATE

DUPAGE COUNTY DIVISION OF TRANSPORTATION
2022 PAVEMENT MAINTENANCE
NORTH REGION
GENEVA ROAD
PAVEMENT MARKING PLAN

DATE: 1/04/22

DRAWN BY: TH
DESIGNED BY:
CHECKED BY:

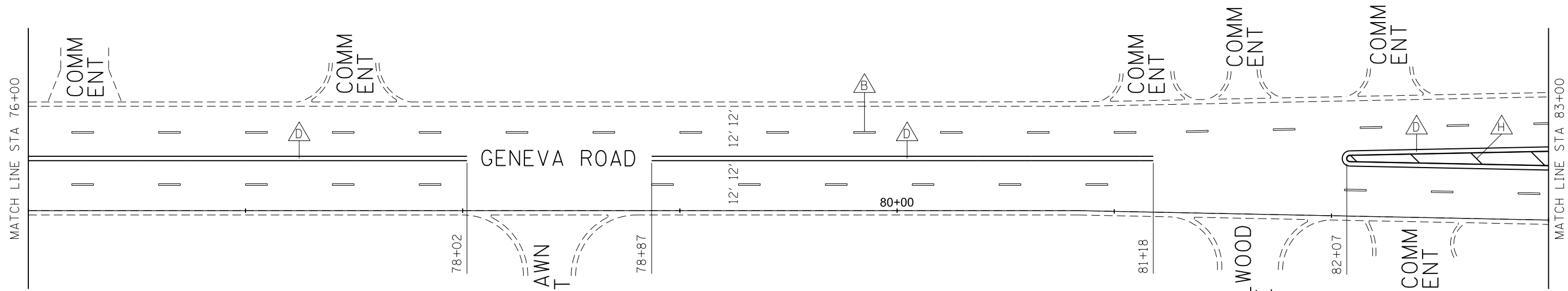

NOTES:

1.) THE LOCATIONS OF TRAFFIC SIGNAL HANDHOLES AND DETECTOR LOOPS ARE APPROXIMATE. THE ACTUAL LOCATIONS SHALL BE CONFIRMED IN THE FIELD.



SCALE IN FEET

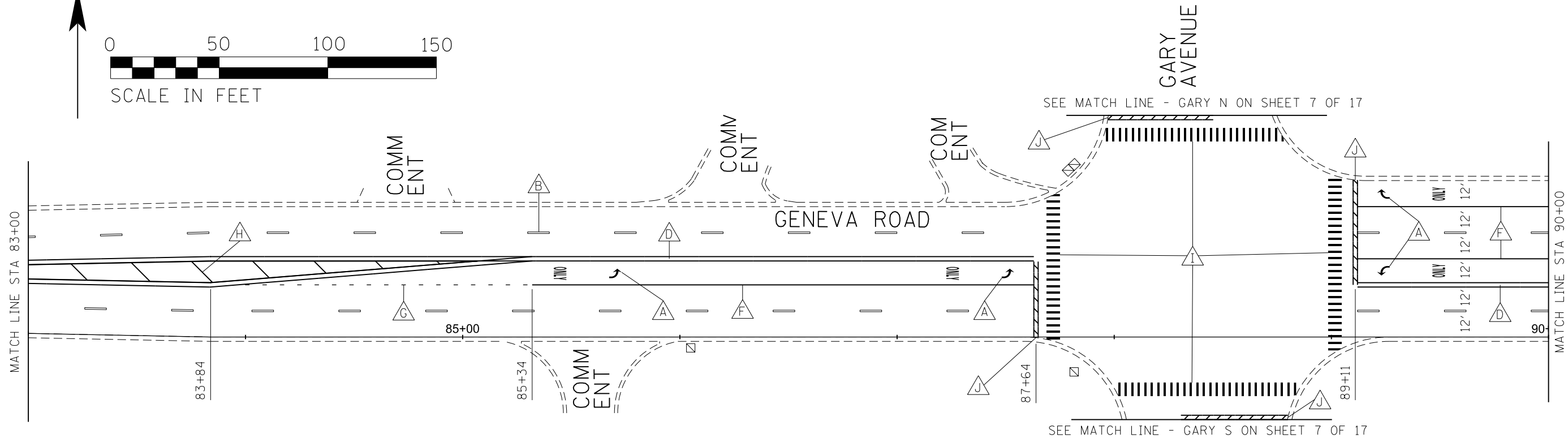

PAVEMENT MARKING LEGEND

- | | |
|---|---|
| THERMOPLASTIC PAVEMENT MARKING, LETTERS AND SYMBOLS | THERMOPLASTIC PAVEMENT MARKING - LINE 6", WHITE, 6' SKIP, 2' DASH |
| THERMOPLASTIC PAVEMENT MARKING - LINE 4", WHITE SKIP DASH | THERMOPLASTIC PAVEMENT MARKING - LINE 12", SOLID YELLOW |
| THERMOPLASTIC PAVEMENT MARKING - LINE 4", SOLID YELLOW | THERMOPLASTIC PAVEMENT MARKING - LINE 12", SOLID WHITE |
| THERMOPLASTIC PAVEMENT MARKING - LINE 4", DOUBLE YELLOW | THERMOPLASTIC PAVEMENT MARKING - LINE 24", SOLID WHITE |
| THERMOPLASTIC PAVEMENT MARKING - LINE 4", SOLID WHITE | THERMOPLASTIC PAVEMENT MARKING - LINE 8", SOLID WHITE |
| THERMOPLASTIC PAVEMENT MARKING - LINE 6", SOLID WHITE | THERMOPLASTIC PAVEMENT MARKING - LINE 4", YELLOW SKIP DASH |
| | PROPOSED TRAFFIC SIGNAL DETECTOR LOOP |

REVISIONS	
NAME	DATE

DUPAGE COUNTY DIVISION OF TRANSPORTATION
2022 PAVEMENT MAINTENANCE
NORTH REGION
GENEVA ROAD
PAVEMENT MARKING PLAN

DATE: 1/04/22

DRAWN BY: TH
DESIGNED BY:
CHECKED BY:

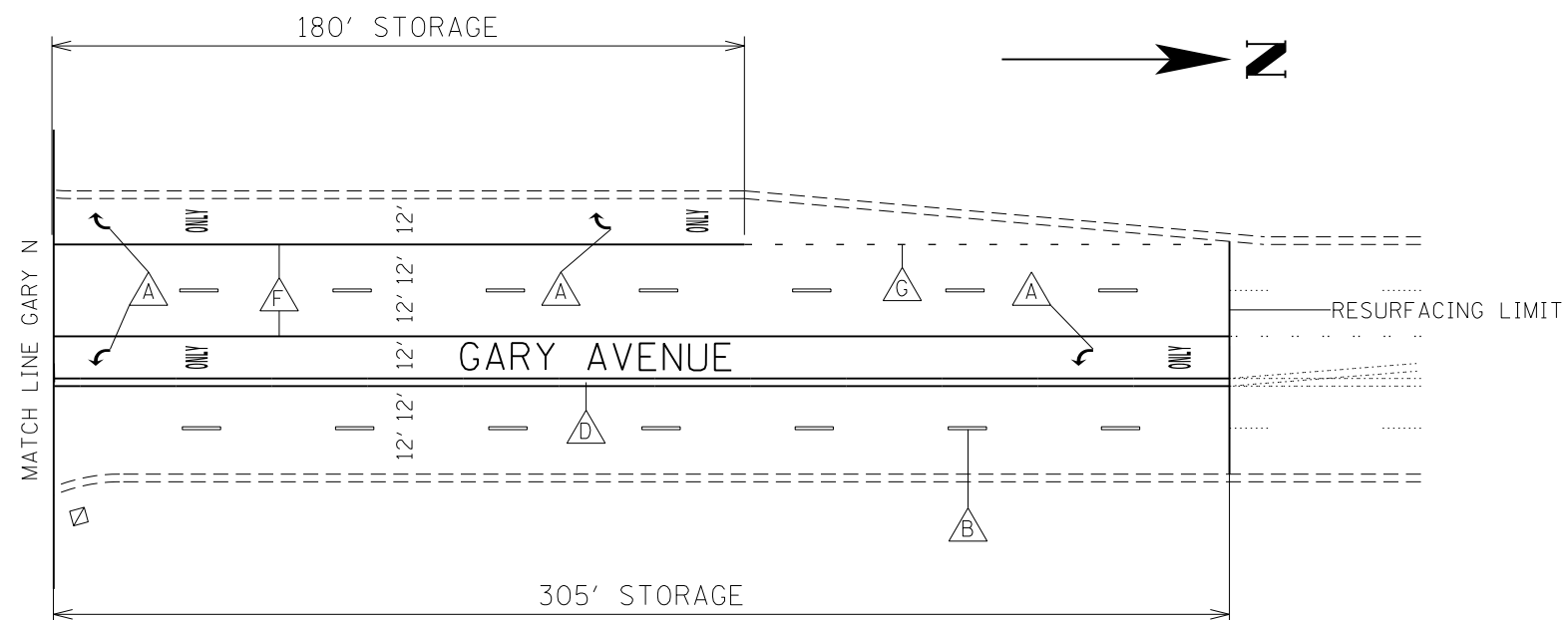

NOTES:

1.) THE LOCATIONS OF TRAFFIC SIGNAL HANDHOLES AND DETECTOR LOOPS ARE APPROXIMATE. THE ACTUAL LOCATIONS SHALL BE CONFIRMED IN THE FIELD.

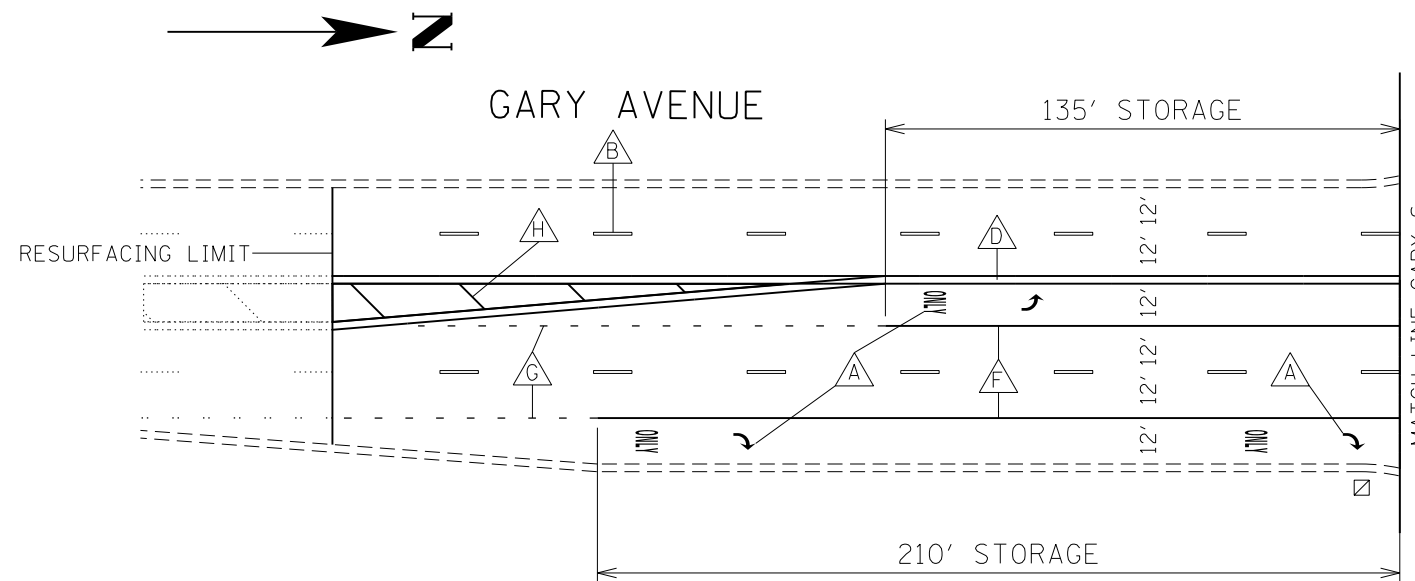

PAVEMENT MARKING LEGEND

- | | |
|---|---|
| △ A THERMOPLASTIC PAVEMENT MARKING, LETTERS AND SYMBOLS | △ G THERMOPLASTIC PAVEMENT MARKING - LINE 6", WHITE, 6' SKIP, 2' DASH |
| △ B THERMOPLASTIC PAVEMENT MARKING - LINE 4", WHITE SKIP DASH | △ H THERMOPLASTIC PAVEMENT MARKING - LINE 12", SOLID YELLOW |
| △ C THERMOPLASTIC PAVEMENT MARKING - LINE 4", SOLID YELLOW | △ I THERMOPLASTIC PAVEMENT MARKING - LINE 12", SOLID WHITE |
| △ D THERMOPLASTIC PAVEMENT MARKING - LINE 4", DOUBLE YELLOW | △ J THERMOPLASTIC PAVEMENT MARKING - LINE 24", SOLID WHITE |
| △ E THERMOPLASTIC PAVEMENT MARKING - LINE 4", SOLID WHITE | △ K THERMOPLASTIC PAVEMENT MARKING - LINE 8", SOLID WHITE |
| △ F THERMOPLASTIC PAVEMENT MARKING - LINE 6", SOLID WHITE | △ L THERMOPLASTIC PAVEMENT MARKING - LINE 4", YELLOW SKIP DASH |
| | □ PROPOSED TRAFFIC SIGNAL DETECTOR LOOP |

REVISIONS	
NAME	DATE

DUPAGE COUNTY DIVISION OF TRANSPORTATION
2022 PAVEMENT MAINTENANCE
NORTH REGION
GENEVA ROAD
PAVEMENT MARKING PLAN

DATE: 1/04/22

DRAWN BY: TH
DESIGNED BY:
CHECKED BY:

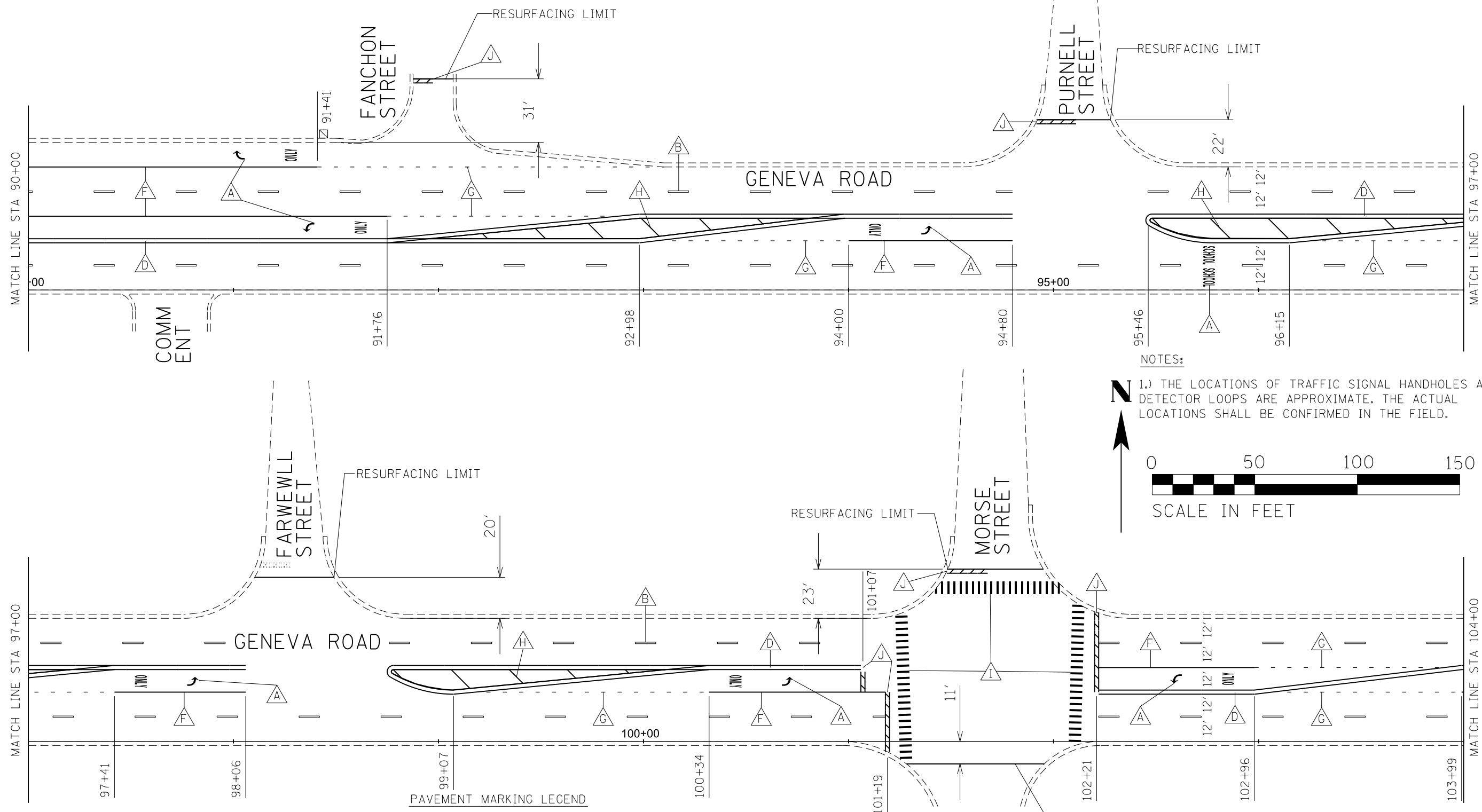

NOTES:
 1.) THE LOCATIONS OF TRAFFIC SIGNAL HANDHOLES AND DETECTOR LOOPS ARE APPROXIMATE. THE ACTUAL LOCATIONS SHALL BE CONFIRMED IN THE FIELD.

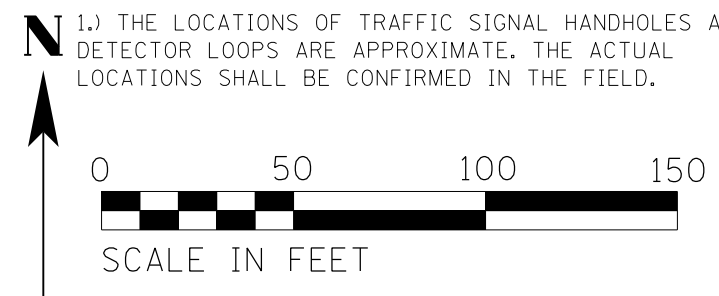

PAVEMENT MARKING LEGEND

- | | |
|---|---|
| △ A THERMOPLASTIC PAVEMENT MARKING, LETTERS AND SYMBOLS | △ G THERMOPLASTIC PAVEMENT MARKING - LINE 6", WHITE, 6' SKIP, 2' DASH |
| △ B THERMOPLASTIC PAVEMENT MARKING - LINE 4", WHITE SKIP DASH | △ H THERMOPLASTIC PAVEMENT MARKING - LINE 12", SOLID YELLOW |
| △ C THERMOPLASTIC PAVEMENT MARKING - LINE 4", SOLID YELLOW | △ I THERMOPLASTIC PAVEMENT MARKING - LINE 12", SOLID WHITE |
| △ D THERMOPLASTIC PAVEMENT MARKING - LINE 4", DOUBLE YELLOW | △ J THERMOPLASTIC PAVEMENT MARKING - LINE 24", SOLID WHITE |
| △ E THERMOPLASTIC PAVEMENT MARKING - LINE 4", SOLID WHITE | △ K THERMOPLASTIC PAVEMENT MARKING - LINE 8", SOLID WHITE |
| △ F THERMOPLASTIC PAVEMENT MARKING - LINE 6", SOLID WHITE | △ L . |
| | □ PROPOSED TRAFFIC SIGNAL DETECTOR LOOP |

REVISIONS	
NAME	DATE

DUPAGE COUNTY DIVISION OF TRANSPORTATION
 2022 PAVEMENT MAINTENANCE
 NORTH REGION
 GENEVA ROAD
 PAVEMENT MARKING PLAN

DATE: 1/04/22

DRAWN BY: TH
 DESIGNED BY:
 CHECKED BY:

NOTES:

1.) THE LOCATIONS OF TRAFFIC SIGNAL HANDHOLES AND DETECTOR LOOPS ARE APPROXIMATE. THE ACTUAL LOCATIONS SHALL BE CONFIRMED IN THE FIELD.

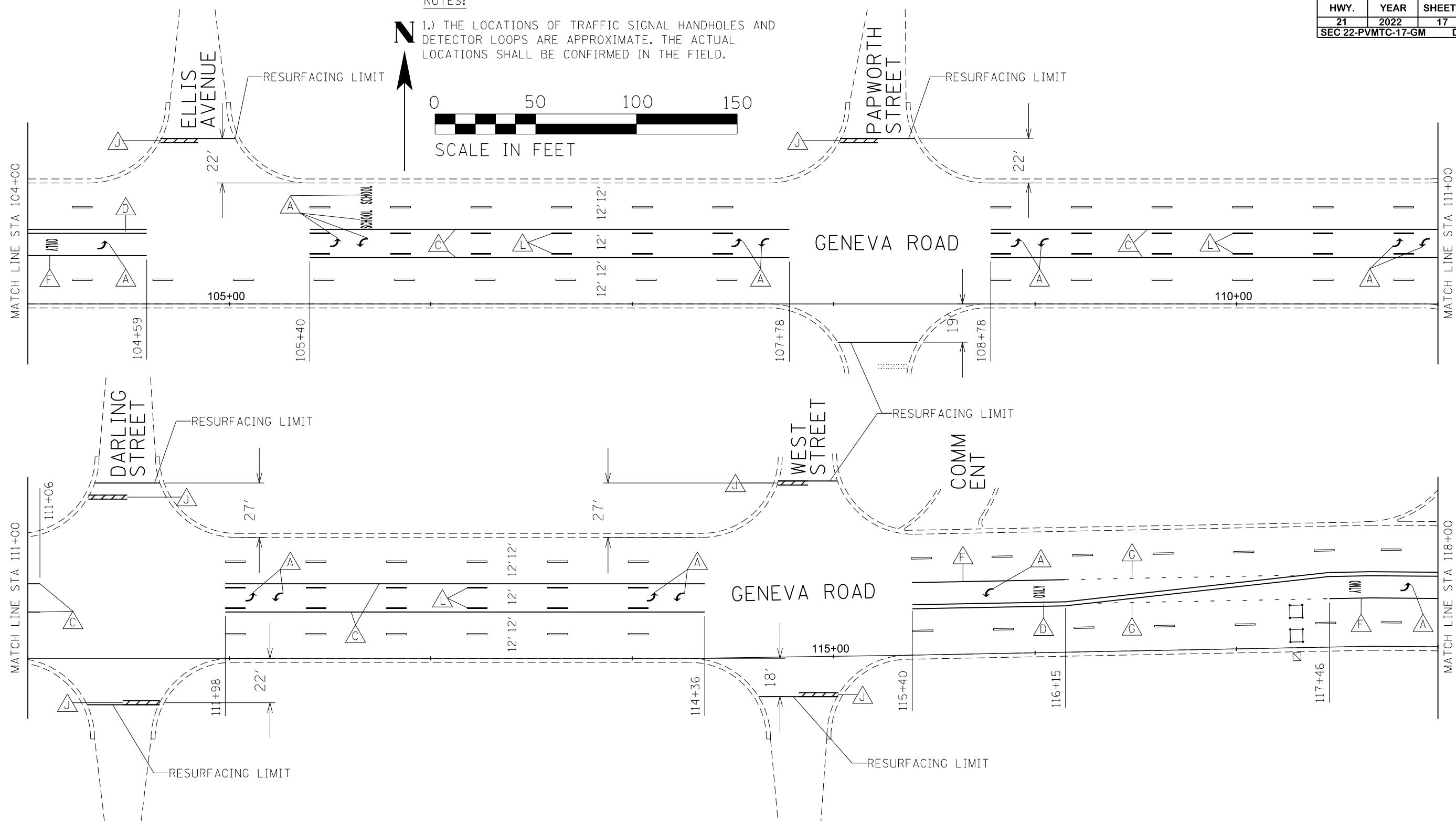

PAVEMENT MARKING LEGEND

- | | |
|---|---|
| △ A THERMOPLASTIC PAVEMENT MARKING, LETTERS AND SYMBOLS | △ G THERMOPLASTIC PAVEMENT MARKING - LINE 6", WHITE, 6' SKIP, 2' DASH |
| △ B THERMOPLASTIC PAVEMENT MARKING - LINE 4", WHITE SKIP DASH | △ H THERMOPLASTIC PAVEMENT MARKING - LINE 12", SOLID YELLOW |
| △ C THERMOPLASTIC PAVEMENT MARKING - LINE 4", SOLID YELLOW | △ I THERMOPLASTIC PAVEMENT MARKING - LINE 12", SOLID WHITE |
| △ D THERMOPLASTIC PAVEMENT MARKING - LINE 4", DOUBLE YELLOW | △ J THERMOPLASTIC PAVEMENT MARKING - LINE 24", SOLID WHITE |
| △ E THERMOPLASTIC PAVEMENT MARKING - LINE 4", SOLID WHITE | △ K THERMOPLASTIC PAVEMENT MARKING - LINE 8", SOLID WHITE |
| △ F THERMOPLASTIC PAVEMENT MARKING - LINE 6", SOLID WHITE | △ L THERMOPLASTIC PAVEMENT MARKING - LINE 4", YELLOW SKIP DASH |
| | □ PROPOSED TRAFFIC SIGNAL DETECTOR LOOP |

REVISIONS	
NAME	DATE

DUPAGE COUNTY DIVISION OF TRANSPORTATION
2022 PAVEMENT MAINTENANCE
NORTH REGION
GENEVA ROAD
PAVEMENT MARKING PLAN

DATE: 1/04/22

DRAWN BY: TH
DESIGNED BY:
CHECKED BY:

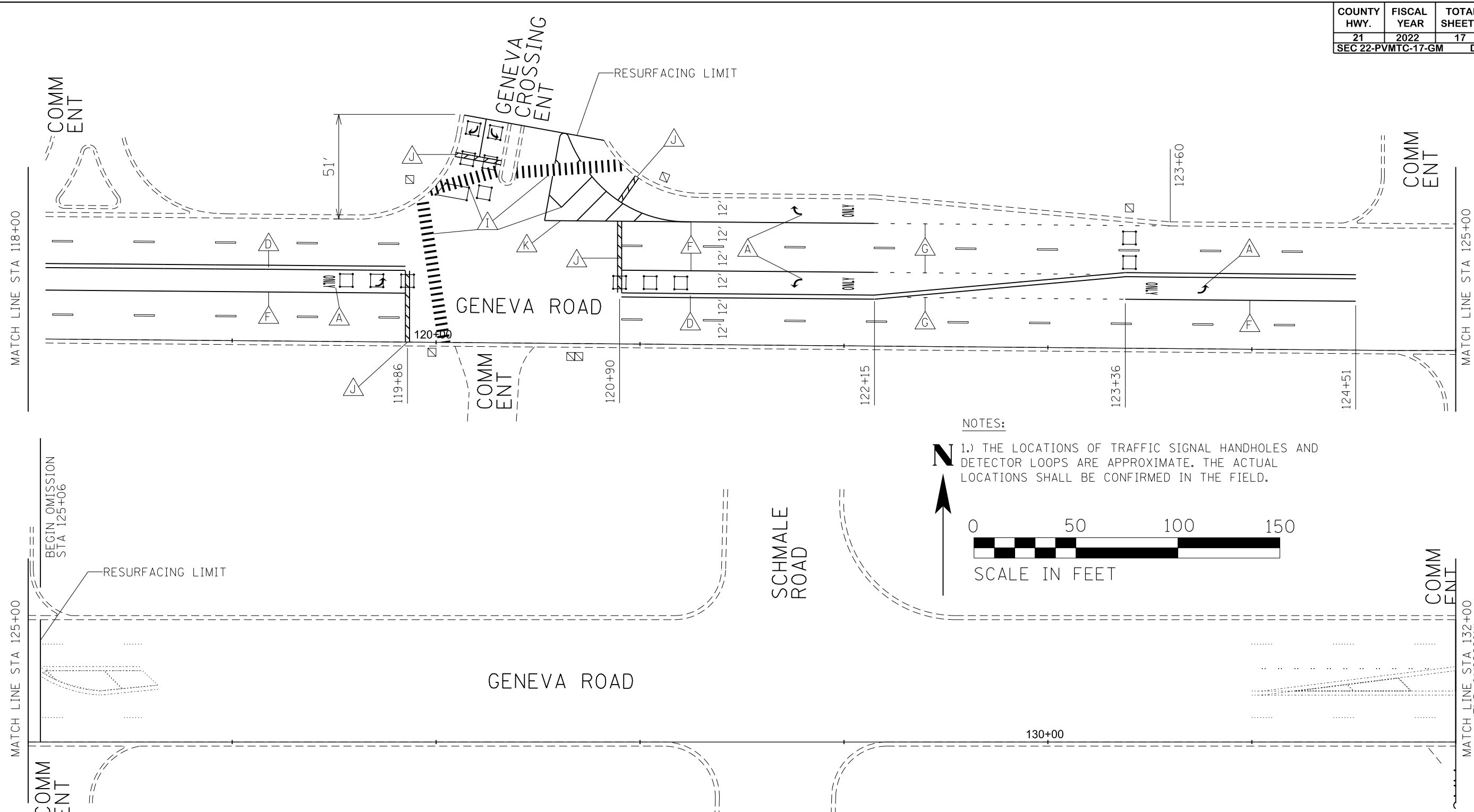

NOTES:

1.) THE LOCATIONS OF TRAFFIC SIGNAL HANDHOLES AND DETECTOR LOOPS ARE APPROXIMATE. THE ACTUAL LOCATIONS SHALL BE CONFIRMED IN THE FIELD.

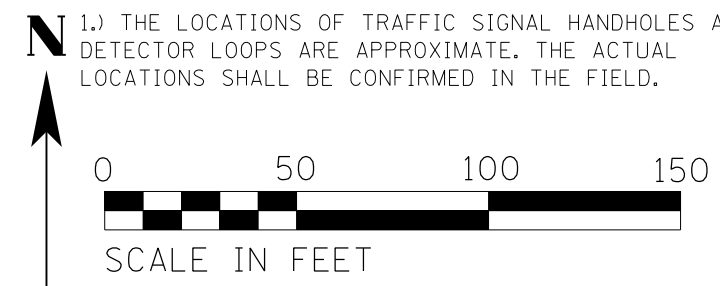

PAVEMENT MARKING LEGEND

- | | |
|---|---|
| △ A THERMOPLASTIC PAVEMENT MARKING, LETTERS AND SYMBOLS | △ G THERMOPLASTIC PAVEMENT MARKING - LINE 6", WHITE, 6' SKIP, 2' DASH |
| △ B THERMOPLASTIC PAVEMENT MARKING - LINE 4", WHITE SKIP DASH | △ H THERMOPLASTIC PAVEMENT MARKING - LINE 12", SOLID YELLOW |
| △ C THERMOPLASTIC PAVEMENT MARKING - LINE 4", SOLID YELLOW | △ I THERMOPLASTIC PAVEMENT MARKING - LINE 12", SOLID WHITE |
| △ D THERMOPLASTIC PAVEMENT MARKING - LINE 4", DOUBLE YELLOW | △ J THERMOPLASTIC PAVEMENT MARKING - LINE 24", SOLID WHITE |
| △ E THERMOPLASTIC PAVEMENT MARKING - LINE 4", SOLID WHITE | △ K THERMOPLASTIC PAVEMENT MARKING - LINE 8", SOLID WHITE |
| △ F THERMOPLASTIC PAVEMENT MARKING - LINE 6", SOLID WHITE | △ L THERMOPLASTIC PAVEMENT MARKING - LINE 4", YELLOW SKIP DASH |
| | □ PROPOSED TRAFFIC SIGNAL DETECTOR LOOP |

REVISIONS	
NAME	DATE

DUPAGE COUNTY DIVISION OF TRANSPORTATION
2022 PAVEMENT MAINTENANCE
NORTH REGION
GENEVA ROAD
PAVEMENT MARKING PLAN

DATE: 1/04/22

DRAWN BY: TH
DESIGNED BY:
CHECKED BY:

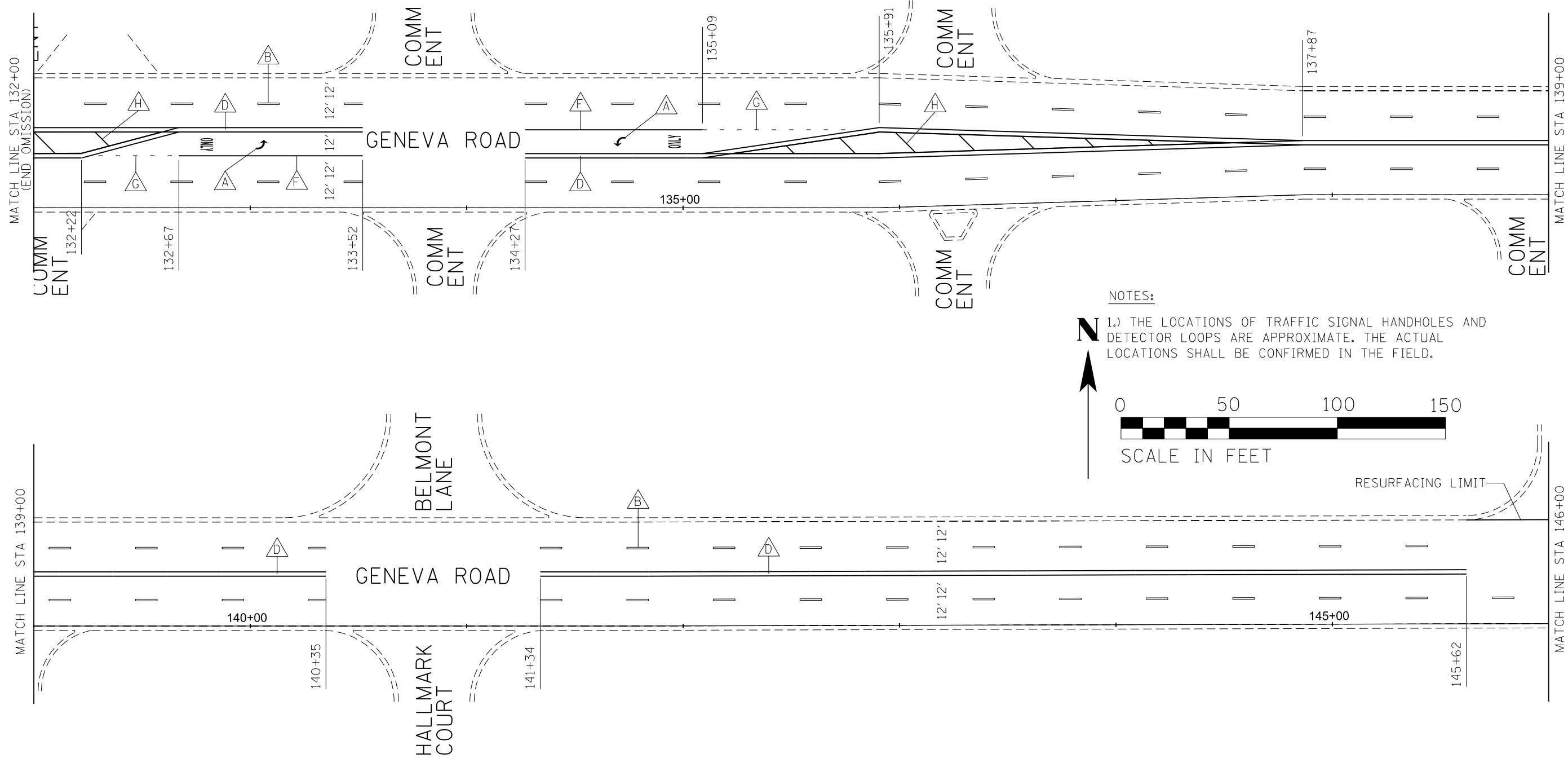

NOTES:

1.) THE LOCATIONS OF TRAFFIC SIGNAL HANDHOLES AND DETECTOR LOOPS ARE APPROXIMATE. THE ACTUAL LOCATIONS SHALL BE CONFIRMED IN THE FIELD.



PAVEMENT MARKING LEGEND

- | | |
|---|---|
| THERMOPLASTIC PAVEMENT MARKING, LETTERS AND SYMBOLS | THERMOPLASTIC PAVEMENT MARKING - LINE 6", WHITE, 6' SKIP, 2' DASH |
| THERMOPLASTIC PAVEMENT MARKING - LINE 4", WHITE SKIP DASH | THERMOPLASTIC PAVEMENT MARKING - LINE 12", SOLID YELLOW |
| THERMOPLASTIC PAVEMENT MARKING - LINE 4", SOLID YELLOW | THERMOPLASTIC PAVEMENT MARKING - LINE 12", SOLID WHITE |
| THERMOPLASTIC PAVEMENT MARKING - LINE 4", DOUBLE YELLOW | THERMOPLASTIC PAVEMENT MARKING - LINE 24", SOLID WHITE |
| THERMOPLASTIC PAVEMENT MARKING - LINE 4", SOLID WHITE | THERMOPLASTIC PAVEMENT MARKING - LINE 8", SOLID WHITE |
| THERMOPLASTIC PAVEMENT MARKING - LINE 6", SOLID WHITE | THERMOPLASTIC PAVEMENT MARKING - LINE 4", YELLOW SKIP DASH |
| | PROPOSED TRAFFIC SIGNAL DETECTOR LOOP |

REVISIONS	
NAME	DATE

DUPAGE COUNTY DIVISION OF TRANSPORTATION
2022 PAVEMENT MAINTENANCE
NORTH REGION
GENEVA ROAD
PAVEMENT MARKING PLAN

DATE: 1/04/22

DRAWN BY: TH
DESIGNED BY:
CHECKED BY:

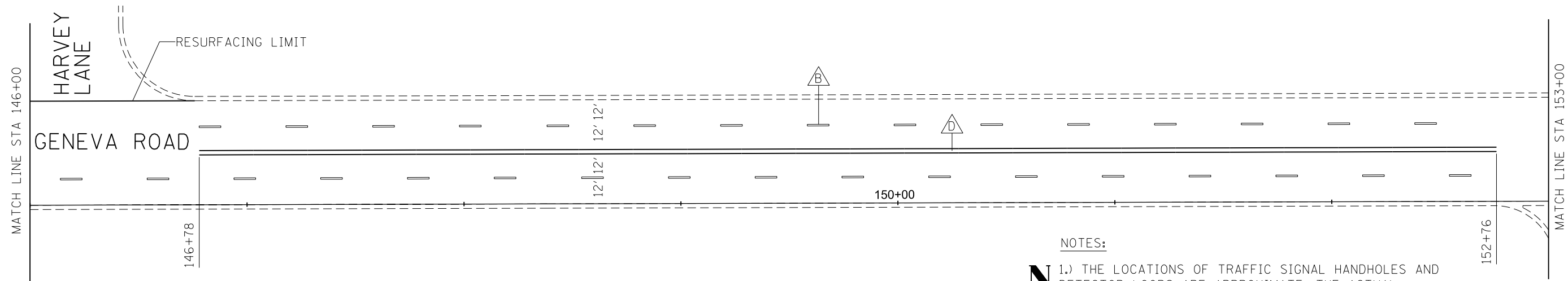

NOTES:

1.) THE LOCATIONS OF TRAFFIC SIGNAL HANDHOLES AND DETECTOR LOOPS ARE APPROXIMATE. THE ACTUAL LOCATIONS SHALL BE CONFIRMED IN THE FIELD.

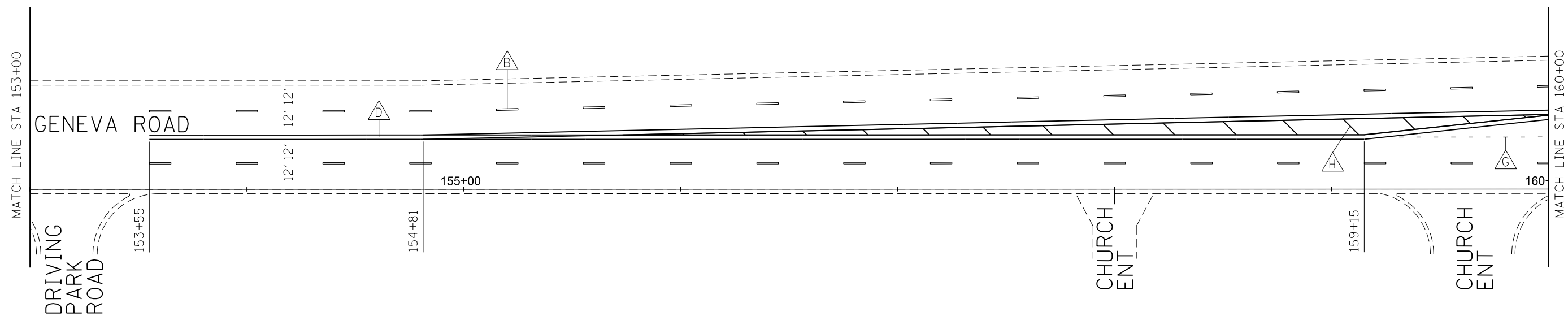

PAVEMENT MARKING LEGEND

- | | |
|---|---|
| △ A THERMOPLASTIC PAVEMENT MARKING, LETTERS AND SYMBOLS | △ G THERMOPLASTIC PAVEMENT MARKING - LINE 6", WHITE, 6' SKIP, 2' DASH |
| △ B THERMOPLASTIC PAVEMENT MARKING - LINE 4", WHITE SKIP DASH | △ H THERMOPLASTIC PAVEMENT MARKING - LINE 12", SOLID YELLOW |
| △ C THERMOPLASTIC PAVEMENT MARKING - LINE 4", SOLID YELLOW | △ I THERMOPLASTIC PAVEMENT MARKING - LINE 12", SOLID WHITE |
| △ D THERMOPLASTIC PAVEMENT MARKING - LINE 4", DOUBLE YELLOW | △ J THERMOPLASTIC PAVEMENT MARKING - LINE 24", SOLID WHITE |
| △ E THERMOPLASTIC PAVEMENT MARKING - LINE 4", SOLID WHITE | △ K THERMOPLASTIC PAVEMENT MARKING - LINE 8", SOLID WHITE |
| △ F THERMOPLASTIC PAVEMENT MARKING - LINE 6", SOLID WHITE | △ L THERMOPLASTIC PAVEMENT MARKING - LINE 4", YELLOW SKIP DASH |
| | □ PROPOSED TRAFFIC SIGNAL DETECTOR LOOP |

REVISIONS	
NAME	DATE

DUPAGE COUNTY DIVISION OF TRANSPORTATION
2022 PAVEMENT MAINTENANCE
NORTH REGION
GENEVA ROAD
PAVEMENT MARKING PLAN

DATE: 1/04/22

DRAWN BY: TH
DESIGNED BY:
CHECKED BY:

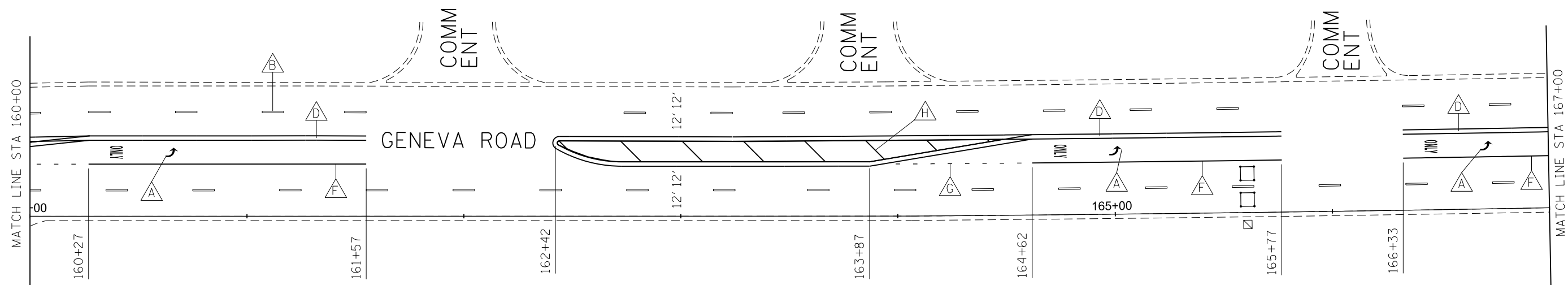

NOTES:

1.) THE LOCATIONS OF TRAFFIC SIGNAL HANDHOLES AND DETECTOR LOOPS ARE APPROXIMATE. THE ACTUAL LOCATIONS SHALL BE CONFIRMED IN THE FIELD.

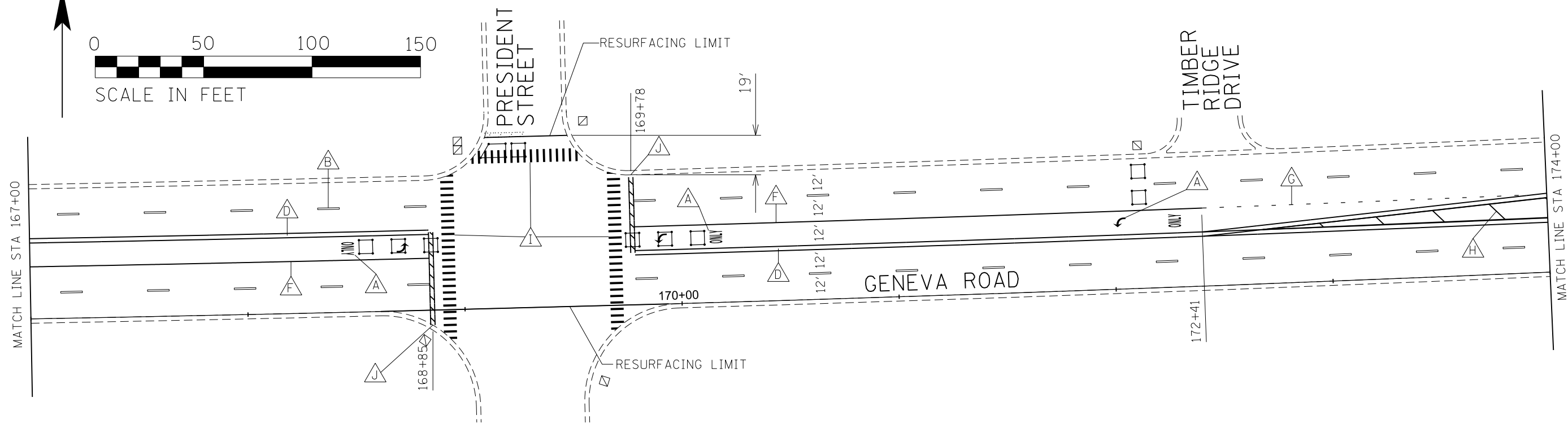
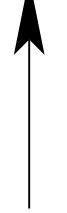

PAVEMENT MARKING LEGEND

- | | |
|---|---|
| △ A THERMOPLASTIC PAVEMENT MARKING, LETTERS AND SYMBOLS | △ G THERMOPLASTIC PAVEMENT MARKING - LINE 6", WHITE, 6' SKIP, 2' DASH |
| △ B THERMOPLASTIC PAVEMENT MARKING - LINE 4", WHITE SKIP DASH | △ H THERMOPLASTIC PAVEMENT MARKING - LINE 12", SOLID YELLOW |
| △ C THERMOPLASTIC PAVEMENT MARKING - LINE 4", SOLID YELLOW | △ I . |
| △ D THERMOPLASTIC PAVEMENT MARKING - LINE 4", DOUBLE YELLOW | △ J THERMOPLASTIC PAVEMENT MARKING - LINE 24", SOLID WHITE |
| △ E THERMOPLASTIC PAVEMENT MARKING - LINE 4", SOLID WHITE | △ K THERMOPLASTIC PAVEMENT MARKING - LINE 8", SOLID WHITE |
| △ F THERMOPLASTIC PAVEMENT MARKING - LINE 6", SOLID WHITE | △ L THERMOPLASTIC PAVEMENT MARKING - LINE 4", YELLOW SKIP DASH |
| | □ PROPOSED TRAFFIC SIGNAL DETECTOR LOOP |

REVISIONS	
NAME	DATE

DUPAGE COUNTY DIVISION OF TRANSPORTATION
2022 PAVEMENT MAINTENANCE
NORTH REGION
GENEVA ROAD
PAVEMENT MARKING PLAN

DATE: 1/04/22

DRAWN BY: TH
DESIGNED BY:
CHECKED BY:

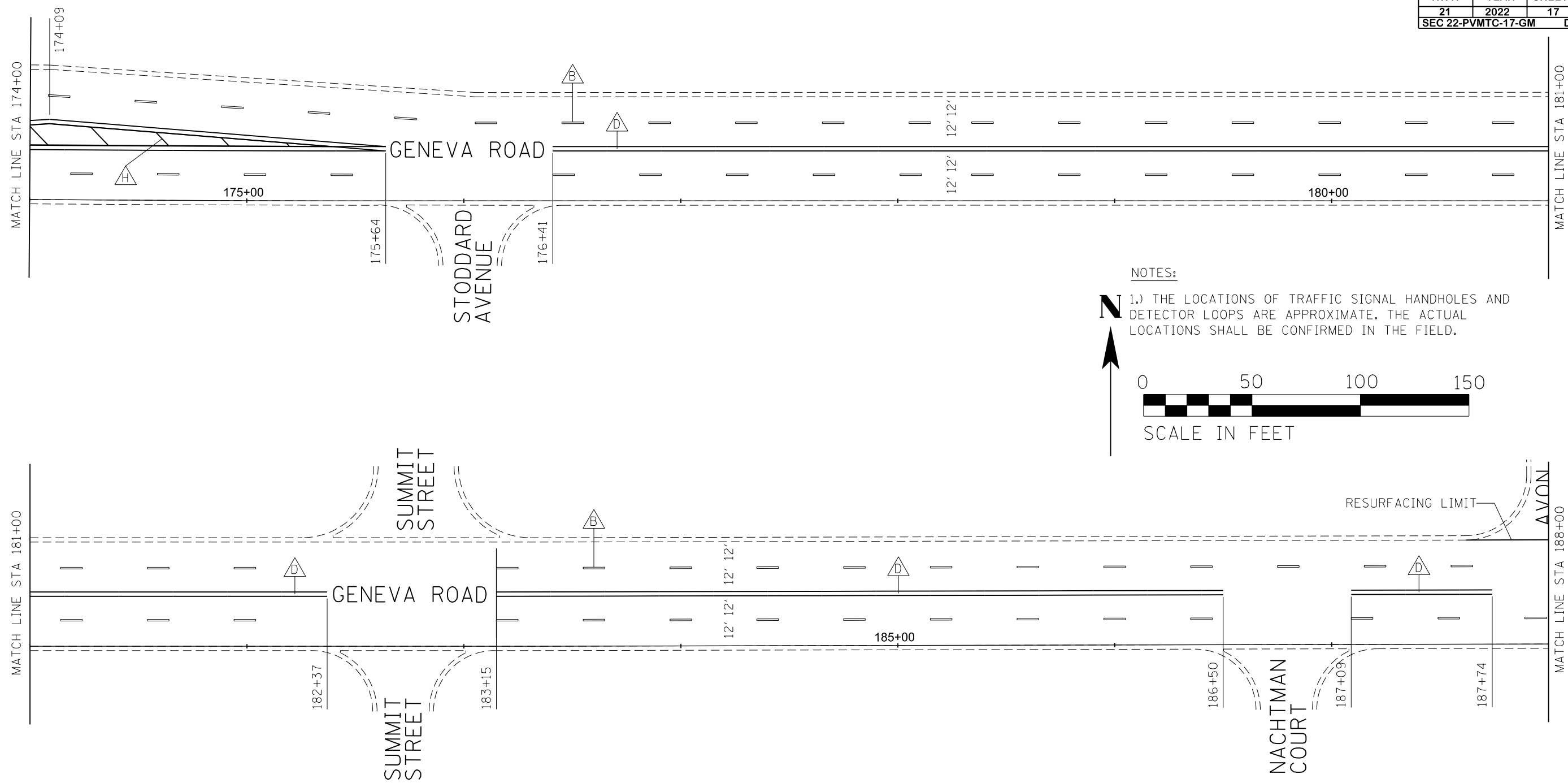

NOTES:

1.) THE LOCATIONS OF TRAFFIC SIGNAL HANDHOLES AND DETECTOR LOOPS ARE APPROXIMATE. THE ACTUAL LOCATIONS SHALL BE CONFIRMED IN THE FIELD.



PAVEMENT MARKING LEGEND

- | | |
|---|---|
| △ A THERMOPLASTIC PAVEMENT MARKING, LETTERS AND SYMBOLS | △ G THERMOPLASTIC PAVEMENT MARKING - LINE 6", WHITE, 6' SKIP, 2' DASH |
| △ B THERMOPLASTIC PAVEMENT MARKING - LINE 4", WHITE SKIP DASH | △ H THERMOPLASTIC PAVEMENT MARKING - LINE 12", SOLID YELLOW |
| △ C THERMOPLASTIC PAVEMENT MARKING - LINE 4", SOLID YELLOW | △ I THERMOPLASTIC PAVEMENT MARKING - LINE 12", SOLID WHITE |
| △ D THERMOPLASTIC PAVEMENT MARKING - LINE 4", DOUBLE YELLOW | △ J THERMOPLASTIC PAVEMENT MARKING - LINE 24", SOLID WHITE |
| △ E THERMOPLASTIC PAVEMENT MARKING - LINE 4", SOLID WHITE | △ K THERMOPLASTIC PAVEMENT MARKING - LINE 8", SOLID WHITE |
| △ F THERMOPLASTIC PAVEMENT MARKING - LINE 6", SOLID WHITE | △ L THERMOPLASTIC PAVEMENT MARKING - LINE 4", YELLOW SKIP DASH |
| | □ PROPOSED TRAFFIC SIGNAL DETECTOR LOOP |

REVISIONS	
NAME	DATE

DUPAGE COUNTY DIVISION OF TRANSPORTATION
2022 PAVEMENT MAINTENANCE
NORTH REGION
GENEVA ROAD
PAVEMENT MARKING PLAN

DATE: 1/04/22

DRAWN BY: TH
DESIGNED BY:
CHECKED BY:

NOTES:

1.) THE LOCATIONS OF TRAFFIC SIGNAL HANDHOLES AND DETECTOR LOOPS ARE APPROXIMATE. THE ACTUAL LOCATIONS SHALL BE CONFIRMED IN THE FIELD.

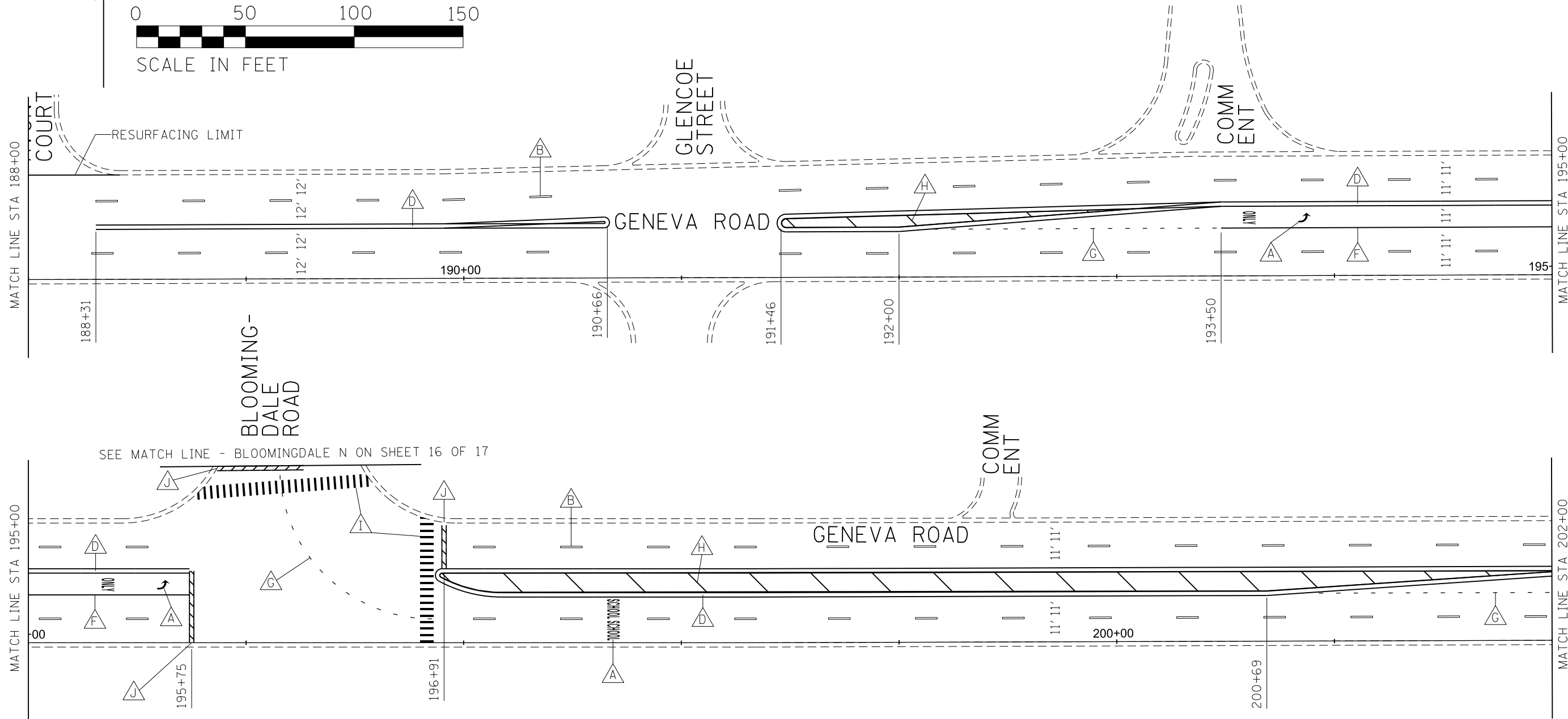

PAVEMENT MARKING LEGEND

- | | |
|--|--|
| A THERMOPLASTIC PAVEMENT MARKING, LETTERS AND SYMBOLS | G THERMOPLASTIC PAVEMENT MARKING - LINE 6", WHITE, 6' SKIP, 2' DASH |
| B THERMOPLASTIC PAVEMENT MARKING - LINE 4", WHITE SKIP DASH | H THERMOPLASTIC PAVEMENT MARKING - LINE 12", SOLID YELLOW |
| C THERMOPLASTIC PAVEMENT MARKING - LINE 4", SOLID YELLOW | I THERMOPLASTIC PAVEMENT MARKING - LINE 12", SOLID WHITE |
| D THERMOPLASTIC PAVEMENT MARKING - LINE 4", DOUBLE YELLOW | J THERMOPLASTIC PAVEMENT MARKING - LINE 24", SOLID WHITE |
| E THERMOPLASTIC PAVEMENT MARKING - LINE 4", SOLID WHITE | K THERMOPLASTIC PAVEMENT MARKING - LINE 8", SOLID WHITE |
| F THERMOPLASTIC PAVEMENT MARKING - LINE 6", SOLID WHITE | L THERMOPLASTIC PAVEMENT MARKING - LINE 4", YELLOW SKIP DASH |
| | □ PROPOSED TRAFFIC SIGNAL DETECTOR LOOP |

REVISIONS	
NAME	DATE

DUPAGE COUNTY DIVISION OF TRANSPORTATION
2022 PAVEMENT MAINTENANCE
NORTH REGION
GENEVA ROAD
PAVEMENT MARKING PLAN

DATE: 1/04/22

DRAWN BY: TH
DESIGNED BY:
CHECKED BY:

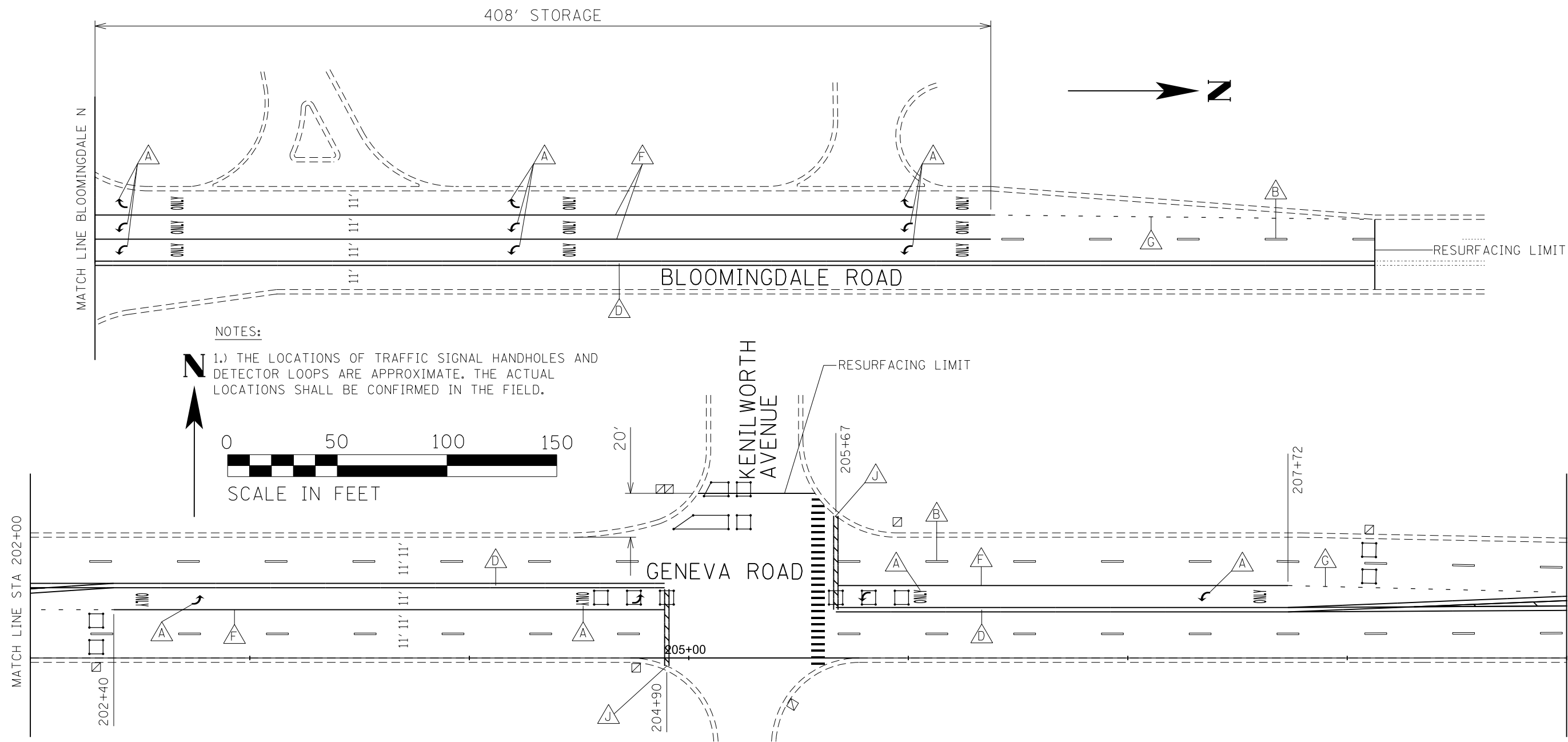

NOTES:
 1.) THE LOCATIONS OF TRAFFIC SIGNAL HANDHOLES AND DETECTOR LOOPS ARE APPROXIMATE. THE ACTUAL LOCATIONS SHALL BE CONFIRMED IN THE FIELD.



PAVEMENT MARKING LEGEND

- | | |
|---|---|
| △ A THERMOPLASTIC PAVEMENT MARKING, LETTERS AND SYMBOLS | △ G THERMOPLASTIC PAVEMENT MARKING - LINE 6", WHITE, 6' SKIP, 2' DASH |
| △ B THERMOPLASTIC PAVEMENT MARKING - LINE 4", WHITE SKIP DASH | △ H THERMOPLASTIC PAVEMENT MARKING - LINE 12", SOLID YELLOW |
| △ C THERMOPLASTIC PAVEMENT MARKING - LINE 4", SOLID YELLOW | △ I THERMOPLASTIC PAVEMENT MARKING - LINE 12", SOLID WHITE |
| △ D THERMOPLASTIC PAVEMENT MARKING - LINE 4", DOUBLE YELLOW | △ J THERMOPLASTIC PAVEMENT MARKING - LINE 24", SOLID WHITE |
| △ E THERMOPLASTIC PAVEMENT MARKING - LINE 4", SOLID WHITE | △ K THERMOPLASTIC PAVEMENT MARKING - LINE 8", SOLID WHITE |
| △ F THERMOPLASTIC PAVEMENT MARKING - LINE 6", SOLID WHITE | △ L THERMOPLASTIC PAVEMENT MARKING - LINE 4", YELLOW SKIP DASH |
| | □ PROPOSED TRAFFIC SIGNAL DETECTOR LOOP |

REVISIONS	
NAME	DATE

DUPAGE COUNTY DIVISION OF TRANSPORTATION
 2022 PAVEMENT MAINTENANCE
 NORTH REGION
 GENEVA ROAD
 PAVEMENT MARKING PLAN

DATE: 1/04/22

DRAWN BY: TH
 DESIGNED BY:
 CHECKED BY:

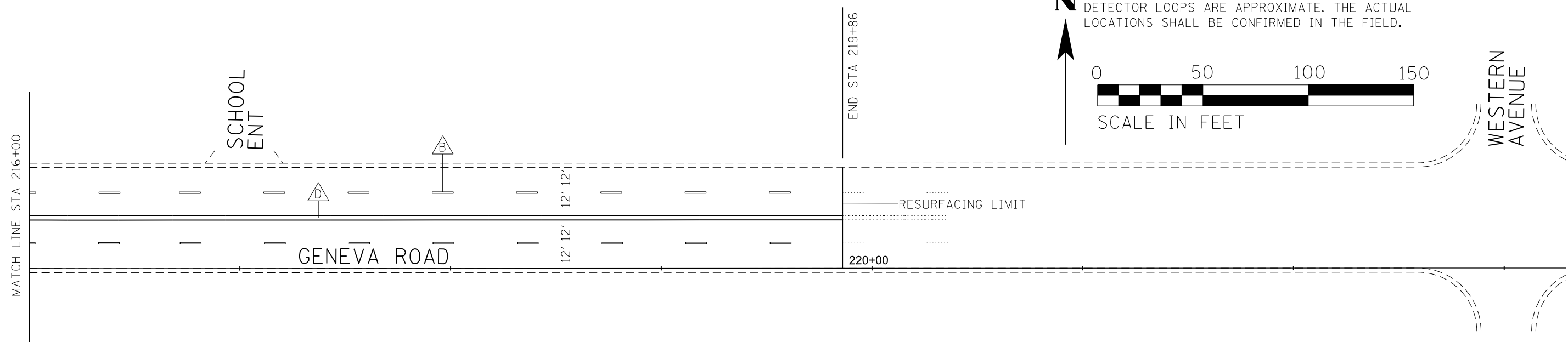
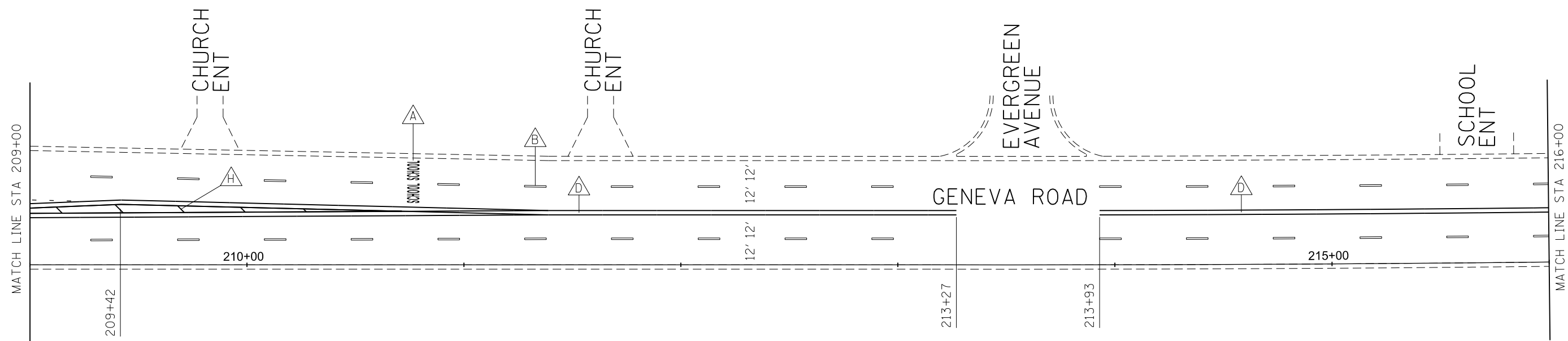

NOTES:

1.) THE LOCATIONS OF TRAFFIC SIGNAL HANDHOLES AND DETECTOR LOOPS ARE APPROXIMATE. THE ACTUAL LOCATIONS SHALL BE CONFIRMED IN THE FIELD.



PAVEMENT MARKING LEGEND

- | | |
|---|---|
| △ A THERMOPLASTIC PAVEMENT MARKING, LETTERS AND SYMBOLS | △ G THERMOPLASTIC PAVEMENT MARKING - LINE 6", WHITE, 6' SKIP, 2' DASH |
| △ B THERMOPLASTIC PAVEMENT MARKING - LINE 4", WHITE SKIP DASH | △ H THERMOPLASTIC PAVEMENT MARKING - LINE 12", SOLID YELLOW |
| △ C | △ I THERMOPLASTIC PAVEMENT MARKING - LINE 12", SOLID WHITE |
| △ D THERMOPLASTIC PAVEMENT MARKING - LINE 4", DOUBLE YELLOW | △ J THERMOPLASTIC PAVEMENT MARKING - LINE 24", SOLID WHITE |
| △ E THERMOPLASTIC PAVEMENT MARKING - LINE 4", SOLID WHITE | △ K THERMOPLASTIC PAVEMENT MARKING - LINE 8", SOLID WHITE |
| △ F THERMOPLASTIC PAVEMENT MARKING - LINE 6", SOLID WHITE | △ L THERMOPLASTIC PAVEMENT MARKING - LINE 4", YELLOW SKIP DASH |
| | □ PROPOSED TRAFFIC SIGNAL DETECTOR LOOP |

REVISIONS	
NAME	DATE

DUPAGE COUNTY DIVISION OF TRANSPORTATION
2022 PAVEMENT MAINTENANCE
NORTH REGION
GENEVA ROAD
PAVEMENT MARKING PLAN

DATE: 1/04/22

DRAWN BY: TH
DESIGNED BY:
CHECKED BY:



CONSTRUCTION NOTES

1. The project will begin 150 ft north of Hawthorne Lane and terminate 1180 ft south of IL Route 64 (North Avenue). Including all side streets up to the county right of way as shown on the pavement marking plans and as determined by the engineer.
2. The proposed improvements include milling – 2 ¼” of the existing HMA surface course, Class D pavement patching, ¾” polymerized leveling binder (machine method), IL – 4.75, N50, longitudinal joint sealant, 1 ½” HMA surface course Mix D N70, aggregate wedge shoulder type B, pavement markings, and recessed pavement markers.
3. Longitudinal joint sealant shall be placed prior to the placement of the HMA surface course. It shall be placed at center line and shoulder paving joints. It shall also be placed at the edge of pavement across side streets.
4. Railroad Right of Entry and Railroad Protective Liability Insurance must be obtained for this location. The ROE shall be obtained from Union Pacific Railroad Company crossing DOT/AAR #175 891 D. HMA surface removal shall not begin at this location prior to the Railroad Right of Entry being obtained.

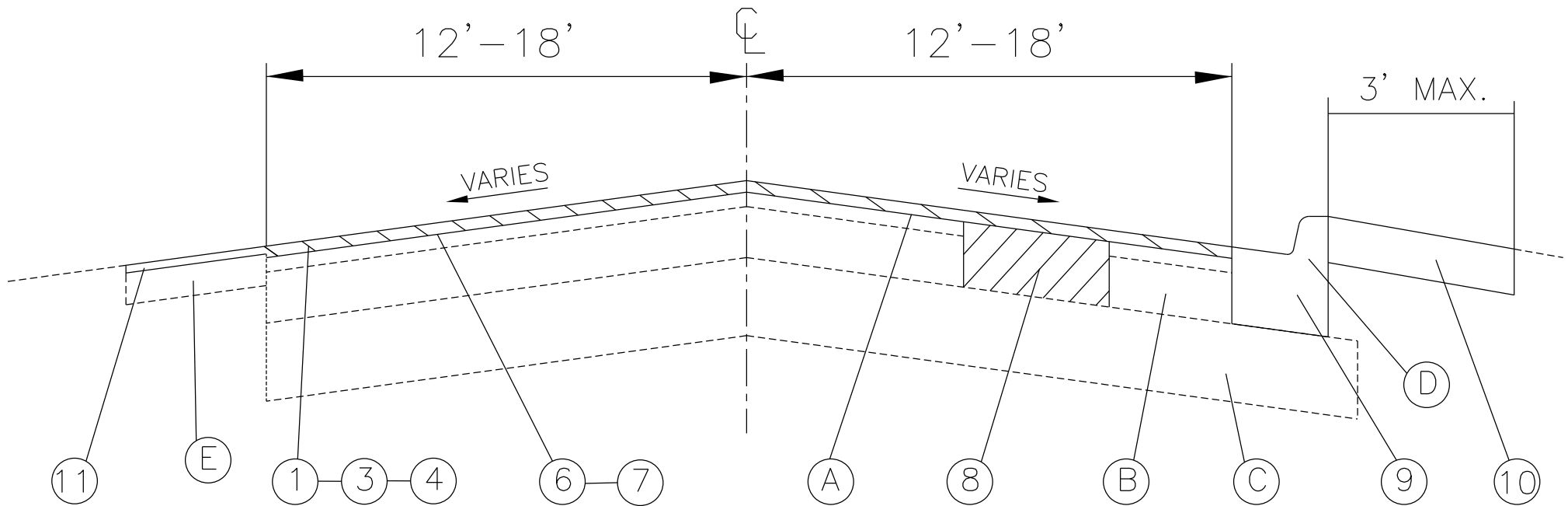

CH 18 / POWIS ROAD
 HAWTHORNE BLVD TO SOUTH OF NORTH AVE
 TYPICAL SECTION

- ① HMA SURFACE REMOVAL, 2¼"
- ② HMA SURFACE REMOVAL, 2½"
- ③ POLY LEVEL BINDER, HMA, IL 4.75 N50 ¾"
- ④ HMA SURFACE COURSE MIX D, N70, 1½"
- ⑤ POLY HMA SURFACE COURSE MIX E, N70, 1¾"
- ⑥ BITUMINOUS MATERIALS (TACK COAT)
- ⑦ AGGREGATE FOR COVERING TACK COAT (AS NEEDED)
- ⑧ CLASS D PATCH, 10" (AS DIRECTED BY THE ENGINEER)
- ⑨ COMBINATION CONCRETE CURB & GUTTER REMOVAL AND REPLACEMENT (AS DIRECTED BY THE ENGINEER)
- ⑩ CLASS 2A SEED AND BLANKET MIN. 6" TOPSOIL
- ⑪ AGGREGATE WEDGE SHOULDER, TYPE B (AS DIRECTED BY THE ENGINEER)

- Ⓐ EXISTING BITUMINOUS BINDER & SURFACE (3")
- Ⓑ EXISTING BITUMINOUS BASE COURSE - 9"
- Ⓒ EXISTING AGGREGATE SUBGRADE
- Ⓓ EXISTING COMBINATION CONCRETE CURB AND GUTTER, TYPE B-6.18
- Ⓔ EXISTING AGGREGATE SHOULDER
- * CURB AND GUTTER/SHOULDER LOCATIONS VARY

NOTES:

1.) THE LOCATIONS OF TRAFFIC SIGNAL HANDHOLES AND DETECTOR LOOPS ARE APPROXIMATE. THE ACTUAL LOCATIONS SHALL BE CONFIRMED IN THE FIELD.

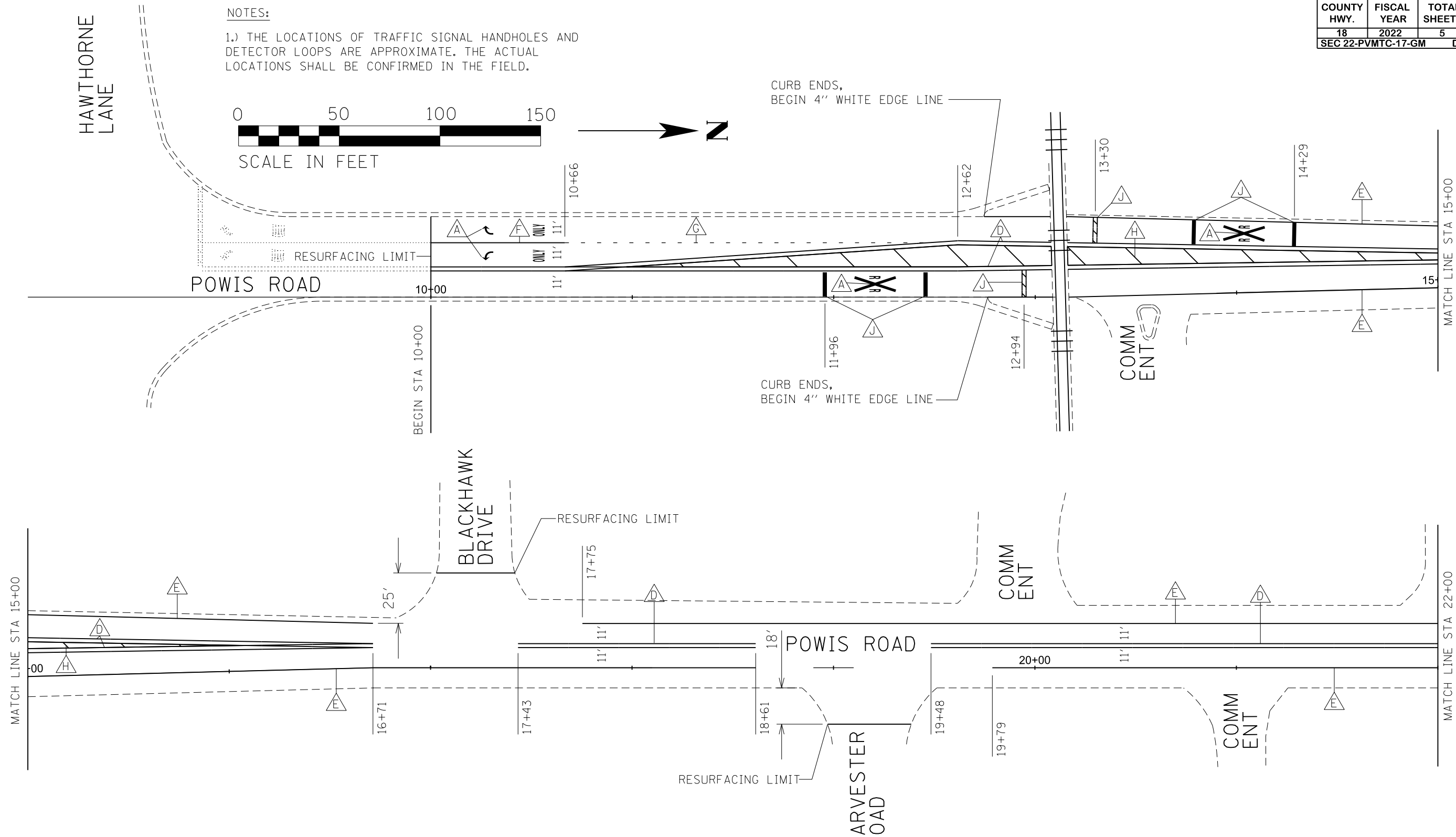

PAVEMENT MARKING LEGEND

- | | |
|---|---|
| THERMOPLASTIC PAVEMENT MARKING, LETTERS AND SYMBOLS | THERMOPLASTIC PAVEMENT MARKING - LINE 6", WHITE, 6' SKIP, 2' DASH |
| THERMOPLASTIC PAVEMENT MARKING - LINE 4", WHITE SKIP DASH | THERMOPLASTIC PAVEMENT MARKING - LINE 12", SOLID YELLOW |
| THERMOPLASTIC PAVEMENT MARKING - LINE 4", SOLID YELLOW | THERMOPLASTIC PAVEMENT MARKING - LINE 12", SOLID WHITE |
| THERMOPLASTIC PAVEMENT MARKING - LINE 4", DOUBLE YELLOW | THERMOPLASTIC PAVEMENT MARKING - LINE 24", SOLID WHITE |
| THERMOPLASTIC PAVEMENT MARKING - LINE 4", SOLID WHITE | THERMOPLASTIC PAVEMENT MARKING - LINE 8", SOLID WHITE |
| THERMOPLASTIC PAVEMENT MARKING - LINE 6", SOLID WHITE | THERMOPLASTIC PAVEMENT MARKING - LINE 4", YELLOW SKIP DASH |
| | PROPOSED TRAFFIC SIGNAL DETECTOR LOOP |

REVISIONS	
NAME	DATE

DUPAGE COUNTY DIVISION OF TRANSPORTATION
2022 PAVEMENT MAINTENANCE
NORTH REGION
POWIS ROAD
PAVEMENT MARKING PLAN

DATE: 1/12/22

DRAWN BY: TH
DESIGNED BY:
CHECKED BY:

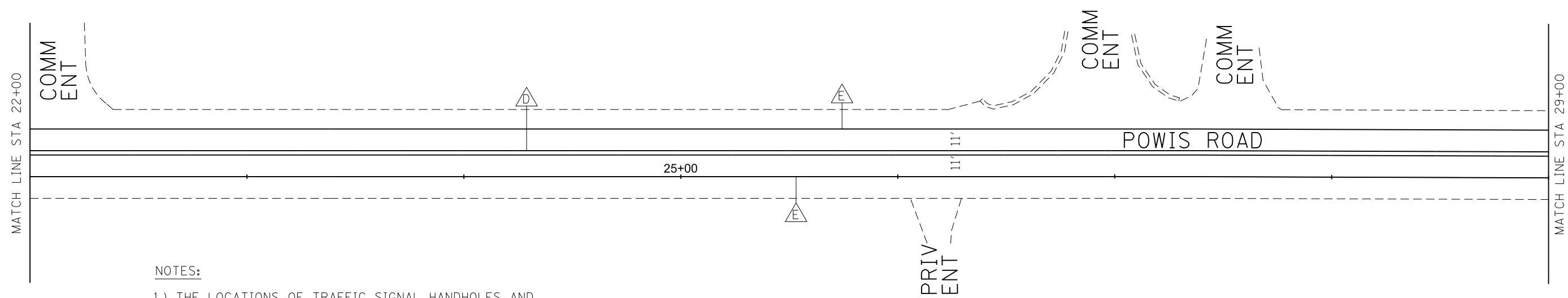

NOTES:
 1.) THE LOCATIONS OF TRAFFIC SIGNAL HANDHOLES AND DETECTOR LOOPS ARE APPROXIMATE. THE ACTUAL LOCATIONS SHALL BE CONFIRMED IN THE FIELD.

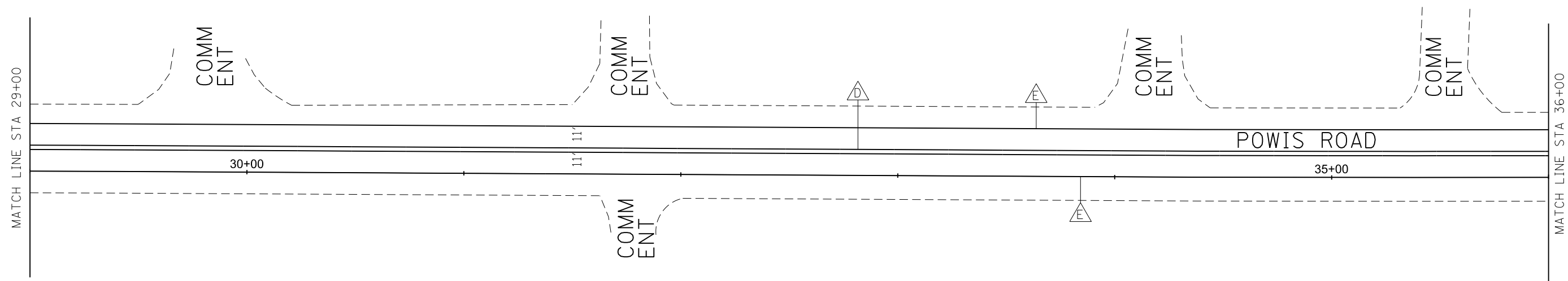
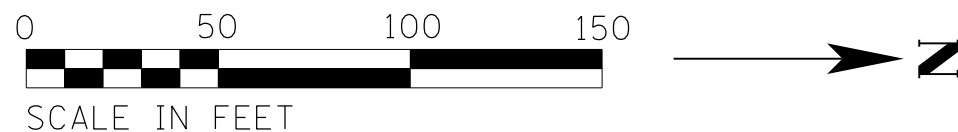

PAVEMENT MARKING LEGEND

- | | |
|---|---|
| △ A THERMOPLASTIC PAVEMENT MARKING, LETTERS AND SYMBOLS | △ G THERMOPLASTIC PAVEMENT MARKING - LINE 6", WHITE, 6' SKIP, 2' DASH |
| △ B THERMOPLASTIC PAVEMENT MARKING - LINE 4", WHITE SKIP DASH | △ H THERMOPLASTIC PAVEMENT MARKING - LINE 12", SOLID YELLOW |
| △ C THERMOPLASTIC PAVEMENT MARKING - LINE 4", SOLID YELLOW | △ I THERMOPLASTIC PAVEMENT MARKING - LINE 12", SOLID WHITE |
| △ D THERMOPLASTIC PAVEMENT MARKING - LINE 4", DOUBLE YELLOW | △ J THERMOPLASTIC PAVEMENT MARKING - LINE 24", SOLID WHITE |
| △ E THERMOPLASTIC PAVEMENT MARKING - LINE 4", SOLID WHITE | △ K THERMOPLASTIC PAVEMENT MARKING - LINE 8", SOLID WHITE |
| △ F THERMOPLASTIC PAVEMENT MARKING - LINE 6", SOLID WHITE | △ L THERMOPLASTIC PAVEMENT MARKING - LINE 4", YELLOW SKIP DASH |
| | □ PROPOSED TRAFFIC SIGNAL DETECTOR LOOP |

REVISIONS	
NAME	DATE

DUPAGE COUNTY DIVISION OF TRANSPORTATION
 2022 PAVEMENT MAINTENANCE
 NORTH REGION
 POWIS ROAD
 PAVEMENT MARKING PLAN

DATE: 1/12/22

DRAWN BY: TH
 DESIGNED BY:
 CHECKED BY:

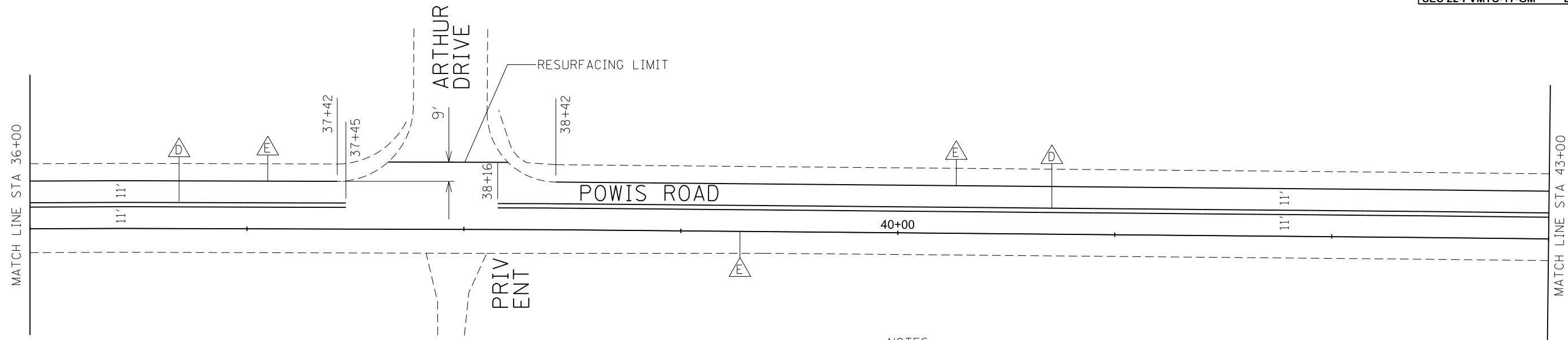

NOTES:
 1.) THE LOCATIONS OF TRAFFIC SIGNAL HANDHOLES AND DETECTOR LOOPS ARE APPROXIMATE. THE ACTUAL LOCATIONS SHALL BE CONFIRMED IN THE FIELD.

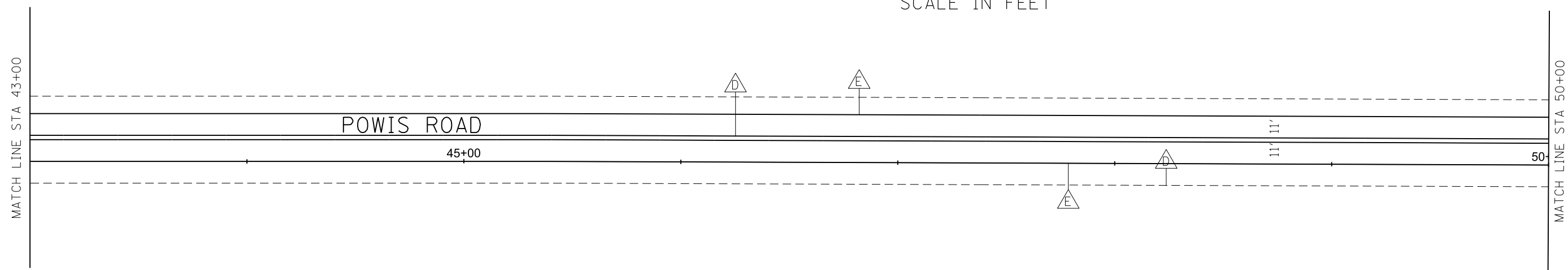
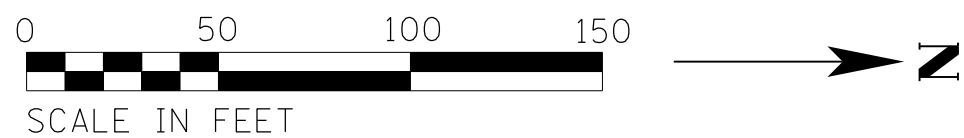

PAVEMENT MARKING LEGEND

- | | |
|---|---|
| △ A THERMOPLASTIC PAVEMENT MARKING, LETTERS AND SYMBOLS | △ G THERMOPLASTIC PAVEMENT MARKING - LINE 6", WHITE, 6' SKIP, 2' DASH |
| △ B THERMOPLASTIC PAVEMENT MARKING - LINE 4", WHITE SKIP DASH | △ H THERMOPLASTIC PAVEMENT MARKING - LINE 12", SOLID YELLOW |
| △ C THERMOPLASTIC PAVEMENT MARKING - LINE 4", SOLID YELLOW | △ I THERMOPLASTIC PAVEMENT MARKING - LINE 12", SOLID WHITE |
| △ D THERMOPLASTIC PAVEMENT MARKING - LINE 4", DOUBLE YELLOW | △ J THERMOPLASTIC PAVEMENT MARKING - LINE 24", SOLID WHITE |
| △ E THERMOPLASTIC PAVEMENT MARKING - LINE 4", SOLID WHITE | △ K THERMOPLASTIC PAVEMENT MARKING - LINE 8", SOLID WHITE |
| △ F THERMOPLASTIC PAVEMENT MARKING - LINE 6", SOLID WHITE | △ L THERMOPLASTIC PAVEMENT MARKING - LINE 4", YELLOW SKIP DASH |
| | □ PROPOSED TRAFFIC SIGNAL DETECTOR LOOP |

REVISIONS	
NAME	DATE

DUPAGE COUNTY DIVISION OF TRANSPORTATION
 2022 PAVEMENT MAINTENANCE
 NORTH REGION
 POWIS ROAD
 PAVEMENT MARKING PLAN

DATE: 1/12/22

DRAWN BY: TH
 DESIGNED BY:
 CHECKED BY:

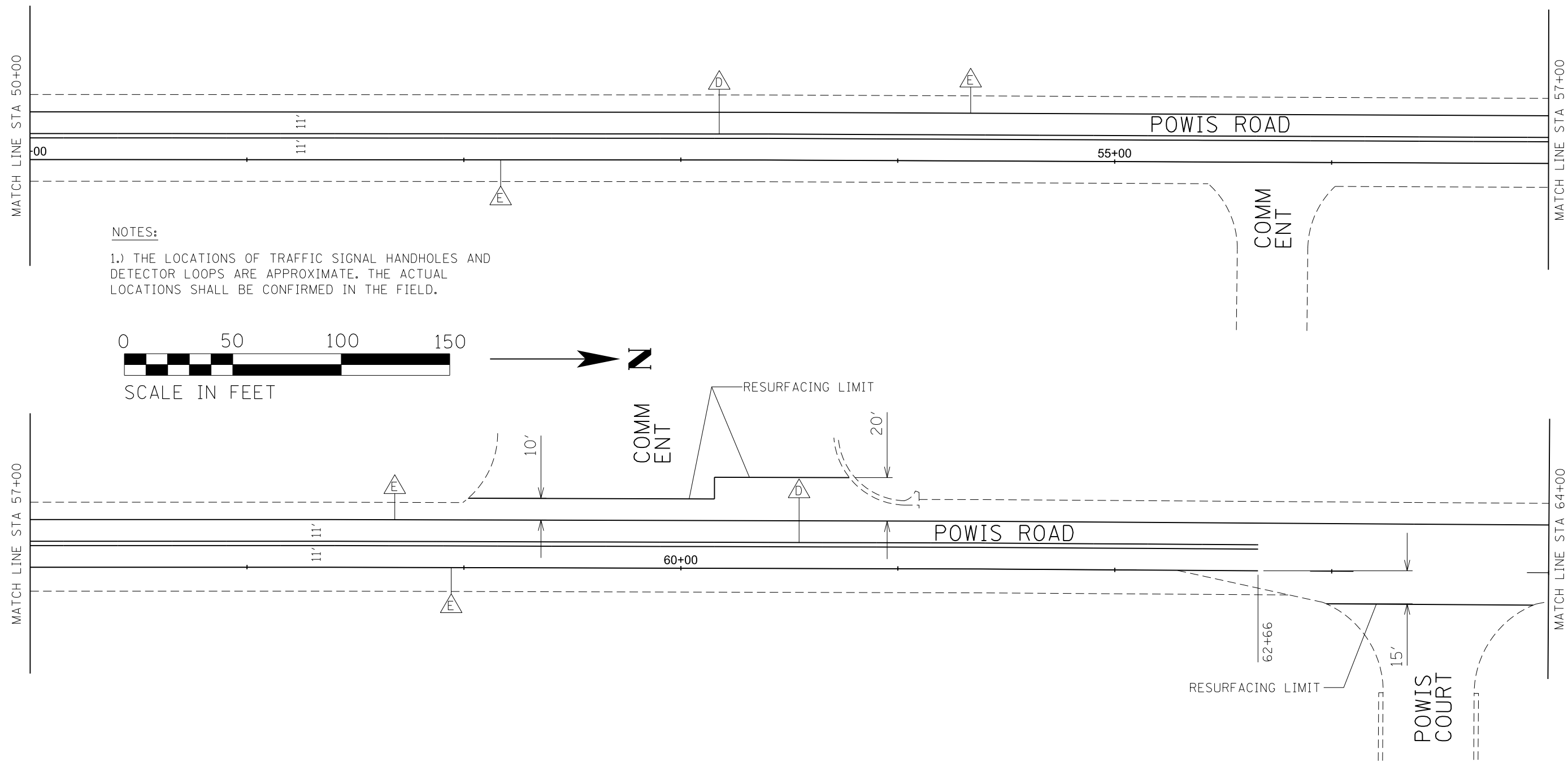

NOTES:

1.) THE LOCATIONS OF TRAFFIC SIGNAL HANDHOLES AND DETECTOR LOOPS ARE APPROXIMATE. THE ACTUAL LOCATIONS SHALL BE CONFIRMED IN THE FIELD.

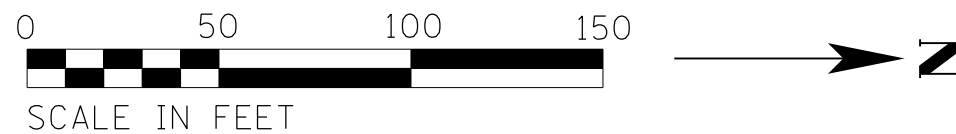

PAVEMENT MARKING LEGEND

- | | |
|---|---|
| △ A THERMOPLASTIC PAVEMENT MARKING, LETTERS AND SYMBOLS | △ G THERMOPLASTIC PAVEMENT MARKING - LINE 6", WHITE, 6' SKIP, 2' DASH |
| △ B THERMOPLASTIC PAVEMENT MARKING - LINE 4", WHITE SKIP DASH | △ H THERMOPLASTIC PAVEMENT MARKING - LINE 12", SOLID YELLOW |
| △ C THERMOPLASTIC PAVEMENT MARKING - LINE 4", SOLID YELLOW | △ I THERMOPLASTIC PAVEMENT MARKING - LINE 12", SOLID WHITE |
| △ D THERMOPLASTIC PAVEMENT MARKING - LINE 4", DOUBLE YELLOW | △ J THERMOPLASTIC PAVEMENT MARKING - LINE 24", SOLID WHITE |
| △ E THERMOPLASTIC PAVEMENT MARKING - LINE 4", SOLID WHITE | △ K THERMOPLASTIC PAVEMENT MARKING - LINE 8", SOLID WHITE |
| △ F THERMOPLASTIC PAVEMENT MARKING - LINE 6", SOLID WHITE | △ L THERMOPLASTIC PAVEMENT MARKING - LINE 4", YELLOW SKIP DASH |
| | □ PROPOSED TRAFFIC SIGNAL DETECTOR LOOP |

REVISIONS	
NAME	DATE

DUPAGE COUNTY DIVISION OF TRANSPORTATION
2022 PAVEMENT MAINTENANCE
NORTH REGION
POWIS ROAD
PAVEMENT MARKING PLAN

DATE: 1/12/22

DRAWN BY: TH
DESIGNED BY:
CHECKED BY:

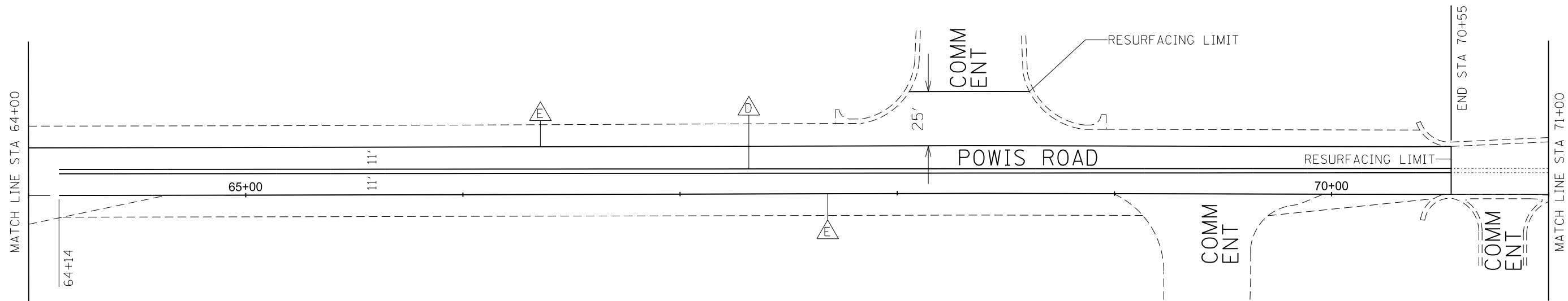

NOTES:

1.) THE LOCATIONS OF TRAFFIC SIGNAL HANDHOLES AND DETECTOR LOOPS ARE APPROXIMATE. THE ACTUAL LOCATIONS SHALL BE CONFIRMED IN THE FIELD.

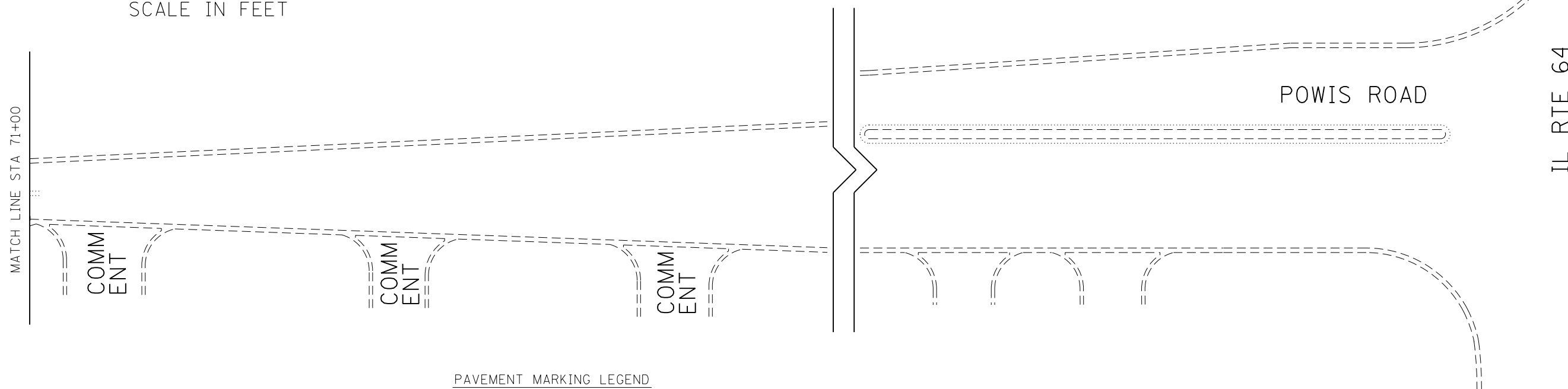
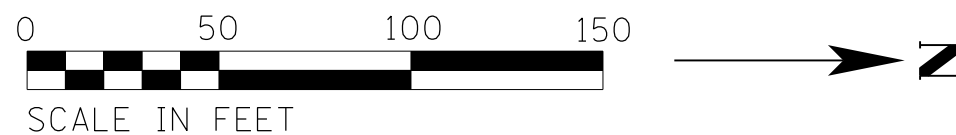

PAVEMENT MARKING LEGEND

- | | |
|--|--|
| A THERMOPLASTIC PAVEMENT MARKING, LETTERS AND SYMBOLS | G THERMOPLASTIC PAVEMENT MARKING - LINE 6", WHITE, 6' SKIP, 2' DASH |
| B THERMOPLASTIC PAVEMENT MARKING - LINE 4", WHITE SKIP DASH | H THERMOPLASTIC PAVEMENT MARKING - LINE 12", SOLID YELLOW |
| C THERMOPLASTIC PAVEMENT MARKING - LINE 4", SOLID YELLOW | I THERMOPLASTIC PAVEMENT MARKING - LINE 12", SOLID WHITE |
| D THERMOPLASTIC PAVEMENT MARKING - LINE 4", DOUBLE YELLOW | J THERMOPLASTIC PAVEMENT MARKING - LINE 24", SOLID WHITE |
| E THERMOPLASTIC PAVEMENT MARKING - LINE 4", SOLID WHITE | K THERMOPLASTIC PAVEMENT MARKING - LINE 8", SOLID WHITE |
| F THERMOPLASTIC PAVEMENT MARKING - LINE 6", SOLID WHITE | L THERMOPLASTIC PAVEMENT MARKING - LINE 4", YELLOW SKIP DASH |
| | □ PROPOSED TRAFFIC SIGNAL DETECTOR LOOP |

REVISIONS	
NAME	DATE

DUPAGE COUNTY DIVISION OF TRANSPORTATION
2022 PAVEMENT MAINTENANCE
NORTH REGION
POWIS ROAD
PAVEMENT MARKING PLAN

DATE: 1/12/22

DRAWN BY: TH
DESIGNED BY:
CHECKED BY:



STATE OF ILLINOIS

SPECIAL PROVISIONS

The following Special Provisions supplement the "Standard Specifications for Road and Bridge Construction", adopted January 1, 2022, the latest edition of the "Manual on Uniform Traffic Control Devices for Streets and Highways", the "Manual of Test Procedures for Materials" in effect on the date of invitation for bids and the "Supplemental Specifications and Recurring Special Provisions" indicated on the Check Sheet included herein which apply to and govern the proposed improvement designated as Section 22-PVMTC-17-GM, and in case of conflict with any part or parts of said Specifications, the said Special Provisions shall take precedence and shall govern.

BIDDING REQUIREMENTS AND CONDITIONS FOR CONTRACT PROPOSALS

(Illinois Department of Transportation Bureau of Local Roads and Streets Special Provision for BIDDING REQUIREMENTS AND CONDITIONS FOR CONTRACT PROPOSALS LRS Check Sheet #6)

Add the following to the section **Prequalification of Bidders**: "Prequalification is required. The Certificate of Eligibility shall be accompanied by a Request for Authorization to Bid form completed by the prospective bidder. The Certificate of Eligibility and Request for Authorization to Bid shall be submitted at least one business day prior to the public opening of proposals. Authorization to bid will be issued by the DuPage County Division of Transportation to prospective bidders who are qualified to perform the work, as evidenced by the Certificate of Eligibility."

Revise the first sentence of the section **Preparation of the Proposal** to read: "Bidders shall submit their proposals on the form furnished by the Awarding Authority or on a form approved by the Awarding Authority prior to submittal of the Proposal."

Add the following to the section **Preparation of the Proposal**: "Unit prices shall only be accepted rounded to the nearest one-hundredth (0.01) of a dollar."

Add the following to the section **Preparation of the Proposal**: "The low bidder shall complete and submit the IRS W-9 form included in this proposal within 48 hours of being notified as the low bidder. The form shall be emailed to Department at DOTBidInfo@dupageco.org. All bidders may either submit the W-9 form with their bid proposal or wait to be notified that they are the low bidder."

Add the following to the section **Public Opening of Proposals**: "Proposals will only be accepted by bidders who have been issued an authorization to bid by the DuPage County Division of Transportation. Proposals submitted without authorization to bid will be returned unopened."

Add the following to after the first sentence of the section **Consideration of Proposals**: "If the Proposal includes quantities and unit prices for multiple agencies, then the summation to be compared shall include all items and not just the items for a single agency."

SECTION 107 LEGAL REGULATIONS AND RESPONSIBILITY TO PUBLIC

Article 107.20 Protection and Restoration of Property. Add the following after the first paragraph of this Article:

“The Contractor shall maintain conveyance of all flows during construction of this project. When existing drainage facilities are disturbed, the Contractor shall provide and maintain temporary inlets, outlets, and connections for all private and public drains, sewers, culverts, and other drainage facilities. The Contractor shall provide facilities to take in all storm water which will be received by these drains and sewers, and discharge the same. The Contractor shall provide and maintain a pumping plant, if necessary, and a temporary outlet and be prepared at all time to dispose of water received from these temporary connections until such time that the permanent drainage facilities are in service.”

Revise the last paragraph of this Article to read:

“The cost of all materials and equipment required and all labor necessary to comply with the above Provisions will not be paid for separately, but shall be considered as included in the unit bid prices of the contract, and no additional compensation will be allowed. ”

Article 107.26 Indemnification. In addition to the requirements of this Article, for any activity occurring on an easement or any other property not owned by the Department, the indemnification shall also be extended to the property owners and any tenants thereon.

Article 107.27 Insurance. In addition to the requirements of this Article, the policies of insurance for Commercial (Comprehensive) General Liability and Commercial (Comprehensive) Automobile Liability shall include an additional insured endorsement naming the County of DuPage, its officers and employees as additional insureds. The endorsements shall be on forms acceptable to the County of DuPage. This additional insured is to be on a primary and non-contributory basis and include a Waiver of Subrogation endorsement.

Employer’s Liability insurance shall be in an amount not less than one million (\$1,000,000.00) dollars each accident/injury and one million (\$1,000,000.00) dollars each employee/disease.

Limits of Umbrella Excess Liability (over primary) shall not be less than an amount that in combination with Commercial General Liability totals \$6,000,000 of liability insurance per occurrence. The Umbrella Excess Liability Policy shall include in the “Who is Insured” pages of the policy wording such as “Any other person or organization you have agreed in a written contract to provide additional insurance” or wording to that affect. The contractor shall provide a copy of said section of the excess/umbrella liability policy upon request by the County of DuPage.

The Contractor shall require all subcontractors to maintain the same insurance coverage required of the contractor. The County of DuPage retains the right to obtain evidence of subcontractor insurance coverage at any time.

Replace the second sentence of the second paragraph (third to last paragraph) of this article with the following: “It is the duty of the Contractor to immediately notify the County of DuPage if any insurance required under this contract has been cancelled, materially changed, or renewal has been refused, and the Contractor shall immediately suspend all work in progress and take the necessary steps to purchase, maintain and provide the required insurance coverage. If a suspension of work should occur due to insurance requirements, upon verification by the County of DuPage of the required insurance coverage, the County of DuPage shall notify the Contractor that the Contractor can proceed with the work that is a part of this contract. Failure to provide and maintain the required insurance coverage could result in the immediate cancellation

of this contract, and the Contractor shall accept and bear all costs that may result from the cancellation of this contract due to Contractor's failure to provide and maintain the required insurance.”

Article 107.36 Dust Control. Add the following to the second paragraph of this article:

“The Contractor will be required to have available a water truck or similar equipment to control dust. If necessary, the Contractor shall be required to control dust during non-working hours.”

SECTION 108 PROSECUTION AND PROGRESS

Article 108.03 Prosecution of the Work. Revise the first sentence of this Article to read, "The Contractor shall not begin the work to be performed under the contract without written authorization from the DuPage County Division of Transportation to proceed with the work, and shall commence work not later than 10 days after receiving the authorization to proceed.”

Work on the Geneva Road location shall not begin prior to June 6, 2022 and shall be complete by August 16, 2022.

SECTION 109 MEASUREMENT AND PAYMENT

Article 109.08 Acceptance and Final Payment. Add the following to this Article: “Prior to final payment, an affidavit from the Contractor will be required.”

SECTION 202 EARTH AND ROCK EXCAVATION

Add the following to Article 202.03:

“Excess material (broken concrete, culvert pipe, surplus material from sewer trenches, etc..) shall not be disposed of within the limits of the Right-Of-Way. It shall be the Contractor’s responsibility to select dump sites and obtain permission and all necessary permits to use such dump sites.”

SECTION 208 TRENCH BACKFILL

Revise Article 208.01 to read:

“208.01 Description. This work shall consist of furnishing aggregate for backfilling all trenches made in the subgrade of the proposed improvement, and all trenches where the inner edge of trench is within a zone extending at a 1H:1V slope from the proposed or existing edge of pavement, curb, gutter, curb and gutter, stabilized shoulder, sidewalk, or path.”

Article 208.02 Materials. The use of stone screenings will not be permitted.

SECTION 250 SEEDING

Add the following to Article 250.05:

“The Contractor shall furnish and place additional topsoil to provide a minimum 6” depth of topsoil to the area to be seeded as needed and as directed by the Engineer.”

Add the following to Article 250.06:

“Seeding, except for Seeding, Class 7, shall be performed between April 1 and June 1 or between August 1 and September 30.”

Add the following to Article 250.09(b):

“Seed bed preparation will be measured in square yards of area prepared. Placement of additional top soil as necessary will not be measured for payment, but included in the price for Seed bed preparation.”

Add the following to Article 250.10:

“Seed bed preparation will be paid for at the contract unit price per square yard for SEED BED PREPARATION.

SECTION 311 GRANULAR SUBBASE

Article 311.02 Materials. The materials for Subbase Granular Material shall be restricted to crushed stone CA-6.

SECTION 358 REPAIR AND PREPARATION OF BASE COURSE

Article 358.05 Old Bituminous, Brick and Concrete. Revise (a) Repair. to read: “All loose and defective material shall be removed. Defective material to be removed is to include but not be limited to existing “cold patch” material placed at cracks, joints, holes or other locations on the existing pavement. This material shall be routed out of all cracks and joints, and at other locations within the limits of the project as directed by the Engineer, and filled with Mixture For Cracks, Joints and Flangeways.”

Delete Article 358.06.

Article 358.07 Basis of Payment. Revise the Basis of Payment to read: “The work in connection with the repair and preparation of bases, except materials, will not be paid for separately, but shall be included in the contract unit price for MIXTURE FOR CRACKS, JOINTS AND FLANGEWAYS.”

SECTION 406 HOT-MIX ASPHALT BINDER AND SURFACE COURSE

Article 406.05 Preparation, Tacking or Priming and Leveling of Brick, Concrete, HMA or Aggregate Bases. The placement of bituminous materials for prime or tack coat shall be in accordance with Section 406 of the Standard Specifications with the following revisions and additions:

1. No tack or prime coat material shall be placed between 6:00 A.M. and 9:00 A.M. or between 2:00 P.M. and 6:00 P.M.
2. Prime or tack coat shall not be applied to more than one lane in each direction at a time. Sufficient time shall be allowed for the material to cure between tack or prime material is placed in the adjacent lane.
3. Lanes closed for the placement of prime or tack coat are to be closed using applicable standards for lane closures. The Engineer may allow cone spacing to be increased to a maximum of 150 foot (50 meter) center-to-center spacing to delineate the lane closure.
4. Prime or tack coat shall not be placed more than 72 hours prior to the start of paving.
5. If traffic cannot be kept off fresh prime or tack coat with the above procedures, the Engineer may require the material be placed in conjunction with the paving operation.

Article 406.06(h)(2) Revise the last sentence of the first paragraph to read,

“The longitudinal joint in all lifts shall be at the centerline of the pavement if the roadway comprises two or three lanes in width or if the roadway is more than three lanes in width and echelon paving is specified or at lane width if the roadway is more than three lanes in width and echelon paving is not specified.”

Add the following after the first paragraph of Article 406.08:

“Sawcut construction joints shall be provided at the paving limits, paved commercial or private entrances, and at all side roads. The cost shall be included in the contract unit price for the HMA Surface Course.”

HOT-MIX-ASPHALT – ECHELON PAVING

Description. This work shall consist of placing hot-mix-asphalt (HMA) surface course by means of an echelon paving operation (also known as the “Concurrent Double-Lane Paving Method”), in which the HMA surface course is placed from the outside edge of pavement to the centerline of pavement (or to the inside edge of pavement where raised median is present). Work shall be according to Section 406 of the Standard Specifications and relevant project Special Provisions, except as modified herein.

Echelon paving shall be utilized at the following project locations: Geneva Road.

Equipment. The Contractor shall supply two (2) spreading and finishing machines, and two (2) complete sets of rollers. The Contractor shall utilize a sufficient quantity of trucks to deliver HMA material so that the echelon paving operation is not impeded.

Placing. The HMA shall be placed with two (2) spreading and finishing machines, operating concurrently in echelon (side-by-side with one paver slightly leading the other), to the typical section and grade shown on the plans or as established by the engineer.

In no case shall the distance between the two (2) spreading and finishing machines exceed one hundred fifty feet (150’) as measured from the rear of the lead paver to the rear of the trailing paver, so as not to permit cooling of the longitudinal joint between the two lanes.

The HMA shall be placed first in the lane nearest the outside curb or shoulder by the lead paver. HMA shall then be placed by the trailing paver between the unconfined edge of the first mat to the centerline of pavement or inside edge of pavement.

Construction Joints. The trailing paver shall use a joint matching shoe to match the undisturbed mat laid by the lead paver, when placing the mixture in the adjacent lane. The distance that the screed and end gate of the trailing paver shall extend over the adjacent uncompacted mixture shall be one to two inches (1”-2”). The inside end gate of the trailing paver shall be set at the same level as the bottom of the screed plate on the lead paver. No raking of the joint shall occur. The paving width shall be such that the final pavement markings will be offset from the paving joint at the lane line and/or centerline by a minimum of six inches (6”).

Traffic Control. Traffic control for this work shall be according to the project special provision, TRAFFIC CONTROL PLAN and also meet the following requirements. Flaggers shall be placed at all signalized intersections at which traffic is crossed over to the opposite side of the road. The Contractor shall submit a traffic control plan for each project location for echelon paving. The traffic control plan shall be submitted for review and approval by the Engineer a minimum of one week prior to the echelon paving operation. Changeable Message Signs shall be erected one week prior to echelon paving operations.

Basis of Payment. This work will not be paid for separately but shall be included in the contract unit price for HMA SURFACE COURSE, of the type and thickness specified.

SECTION 440 REMOVAL OF EXISTING PAVEMENT AND APPURTENANCES

Add the following to Article 440.04:

“HMA surface removal shall be tapered from the depth specified in the plans to the existing pavement surface over a distance of four (4) feet at all paving limits. The remaining wedge of HMA surface shall not be removed until the day of final surface placement. The removal of the remaining wedge will be paid for as HMA SURFACE REMOVAL – BUTT JOINT.”

Add the following to the first paragraph of Article 440.07(B):

“When not provided as specific pay items, removal of existing aggregate or HMA pavements, including driveways and paths, shall not be measured for payment under Section 440, but shall be considered Removal and Disposal of Unsuitable Material and measured according to Article 202.07.”

SECTION 602 CATCH BASIN, MANHOLE, INLET, DRAINAGE STRUCTURE, VALVE VAULT CONSTRUCTION, ADJUSTMENT AND RECONSTRUCTION

Article 602.08 Steps. Omit steps in all structures.

Article 602.09 Wooden Baffles. Baffles are required where shown in the standard drawings. Non-wooden baffles may be substituted with the approval of the Engineer.

Article 602.10 Flat Slab Tops. Flat slab tops shall be provided when the depth, measured between the rim elevation and any invert elevation, is less than six feet.

Article 602.11 Furnishing and Placing Castings. Add the following: “Structures adjusted within the pavement where the pavement is removed to allow for adjustment shall be backfilled with Class SI Concrete or as directed by the Engineer. Structures to be adjusted shall be completed in the outside travel lane and this lane opened to traffic prior to breaking out structures in the adjacent travel lane.”

Article 602.16 Basis of Payment. The contract unit price each for Catch Basins, Manholes, Inlets, Drainage Structures or Valve Vaults will not include the cost of furnishing and installing the specified frames and grates, or lids. The cost of furnishing and installing the frames and grates or lids will be paid for at the contract unit price each in accordance with Section 604 of the Standard Specifications. The contract unit price each for Catch Basins to be Reconstructed, Manholes to be Reconstructed, Inlets to be Reconstructed, Drainage Structures to be Reconstructed or Valve Vaults to be Reconstructed shall include the removal and disposal and/or addition of full-diameter structure sections, flat-slab tops, or “cone” sections.

Adjustment or Reconstruction shall include the removal and replacement of all unsuitable two foot diameter adjusting rings.

Adjustment of domestic water valve boxes (Buffalo Boxes) shall not be paid for separately.

The cost of poured inverts in Manholes and Inlets shall be included in the cost of said structures.

SECTION 604 FRAMES, GRATES, AND MEDIAN INLETS

Add the following to Article 604.01 Description. Where closed lids are provided, they shall be furnished with 2-inch raised letters cast into the lid reading “RESTRICTOR”, “SANITARY”, “STORM”, or “WATER” as appropriate.

SECTION 669 REMOVAL AND DISPOSAL OF REGULATED SUBSTANCES

Change the first paragraph of Article 669.10 to read:

“669.10 Method of Measurement. Non-special waste will not be measured for payment. Special waste and hazardous waste soil will be measured for payment according to Article 202.07(b) when performing earth excavation, (Article 502.12(b)) when excavating for structures, or by computing the volume of the trench using the maximum trench width permitted and the actual depth of the trench.”

Change the second paragraph of Article 669.11 to read:

“669.11 Basis of Payment. The transportation and disposal of soil and other materials from an excavation determined to be contaminated, except for materials classified as Non-Special Waste, will be paid for under Article 109.04

Add the following after the third paragraph of Article 669.11:

“Payment for the following described Special Waste Plans and Reports and various analyses shall be made only if the material is a Special Waste and cannot be certified as a Non-Special Waste:”

SECTION 671 MOBILIZATION

Article 671.02 Basis of Payment. Revise this article to read: “Basis of Payment. This work will not be paid for separately, but shall be included in the various items of work.”

SECTION 703 WORK ZONE PAVEMENT MARKING

Temporary paint pavement markings shall be used on all milled surfaces and level binder lifts. Temporary paint shall not be placed on the final surface; short term tape shall be used.

Temporary turn lane markings shall be provided at all locations as shown on the plans including the placement of left or right turn arrows, except as directed by the Engineer.

Article 703.07 Basis of Payment. The cost of removing short-term pavement marking shall be included in the contract unit price per FOOT for SHORT TERM PAVEMENT MARKING

SECTION 1105 PAVEMENT MARKING EQUIPMENT

Delete the last sentence of Article 1105.01(b)

COMBINATION CONCRETE CURB AND GUTTER REMOVAL AND REPLACEMENT

Description. This work shall consist of the removal of existing combination concrete curb and gutter and replacing of it in kind.

Construction Requirements. All work shall be according to the applicable portions of Section 440 and Section 606 of the Standard Specifications and as stated herein.

Curb and gutter replacement shall match the shape and dimensions of the existing curb and gutter unless otherwise specified. The gutter thickness shall match the pavement thickness with a minimum thickness of 12". The repair or replacement of any sidewalk, driveway pavement, or median surface damaged or disturbed in order to complete the work will not be paid for separately, but included in the cost of the item. The repair of any landscaping damaged beyond three feet (3 ft) from the back of curb will not be paid for separately, but included in the cost of the item. Any saw cuts necessary to complete the work will not be paid separately, but included in the cost of the item. The contractor shall saw cut longitudinally along the joint between the curb and gutter and existing pavement prior to removal.

Framing and base preparation shall be complete a minimum of four (4) working hours prior to the scheduled arrival of concrete to allow time for inspection.

If there is concrete base course, 24" #6 epoxy coated bars shall be placed at 24" centers to tie the curb and gutter to the base course. The bars shall be placed at the midpoint of the base course and a minimum of 3" from the bottom of the curb and gutter. This work will not be paid for separately, but included in the cost of the item.

Unsuitable sub-base material shall be removed as directed by the Engineer and replaced either with Sub-Base Granular Material Type B or additional thickness of concrete.

The locations of curb and gutter removal and replacement will be determined by the Engineer in the field.

Basis of payment. This work will be paid for at the contract unit price per FOOT for COMBINATION CONCRETE CURB AND GUTTER REMOVAL AND REPLACEMENT.

DRAINAGE STRUCTURE CLEAN AND PATCH

Description. This work shall consist of the removal of all debris and loose mortar from catch basins, inlets, and manholes and patching with Portland cement mortar.

Construction Requirements. All work shall be completed as required by this special provision and Section 602 of the Standard Specifications.

Basis of Payment. This work will be paid for at the contract unit price EACH for DRAINAGE STRUCTURE CLEAN AND PATCH.

DRAINAGE STRUCTURE TO BE ADJUSTED
DRAINAGE STRUCTURE TO BE RECONSTRUCTED

Description. This work shall consist of the adjustment or reconstruction of manholes, inlets, and catch basins in accordance with Section 602 of the Standard Specifications.

Construction Requirements. In addition to Section 602 of the Standard Specifications, the following shall apply:

Work completed under these items shall include the removal and disposal of unsuitable adjusting rings, brick, or block down to the top of the original structure and rebuilding the structure using adjusting rings, masonry brick or inlet block and setting the frame with grate or lid to finish grade.

Reconstruction shall also include the removal and disposal and/or addition of full-diameter structure sections, flat-slab tops, or “cone” sections.

Only Portland cement mortar shall be used.

The existing frames and grates not used in construction shall become the property of the Contractor and shall be disposed of outside the limits of the right-of-way.

The cost of pavement removal and replacement adjacent to drainage structures adjusted or reconstructed shall be included in the contract unit price for DRAINAGE STRUCTURE TO BE ADJUSTED or DRAINAGE STRUCTURE TO BE RECONSTRUCTED. The material used to replace the pavement shall be Class SI Concrete unless otherwise directed by the Engineer.

Basis of Payment. This work will be paid for at the contract unit price EACH for DRAINAGE STRUCTURE TO BE ADJUSTED or DRAINAGE STRUCTURE TO BE RECONSTRUCTED.

DRAINAGE STRUCTURE TO BE REMOVED

Description. This work shall consist of the removal and disposal of existing manholes, catch basins and inlets.

Construction Requirements. The drainage structures shall be removed and disposed of as specified in Section 605 of the Standard Specifications and the GENERAL NOTES.

The excavated area shall be backfilled as specified in the plans and specifications.

Basis of Payment. This work will be paid for at the contract unit price per EACH for DRAINAGE STRUCTURE TO BE REMOVED.

EMERGENCY POTHOLE PATCHING

The pay item EMERGENCY POTHOLE PATCHING has been established for the payment of costs associated with work needed in order to keep roadways in a safe and passable condition as directed by the Engineer. This is not a bid item, but is included in the proposal as part of the project costs. The Schedule of Prices includes an amount to be included in the bid.

Construction Requirements. The Contractor shall promptly respond to requests from the Engineer to perform emergency patching. Hot mix asphalt shall be used whenever possible, if hot mix is not available cold mix asphalt shall be used. Patching material shall be shoveled into potholes identified by the Engineer and “wheel rolled” with a pickup or dump truck.

Basis of Payment. This work will be paid for according to Article 109.04.

FRAMES AND LIDS TO BE ADJUSTED, SPECIAL

This work shall be according to detail BD-08, Details for Frames and Lids Adjustment with Milling.

Revise “Stage 1” (D) of Detail BD-08 to read:

“Backfill with crushed stone and a minimum 5 Inches HMA surface mix approved by the Engineer”

Revise “Stage 2” of Detail BD-08 to read:

“(AFTER BINDER OR LEVEL BINDER PLACEMENT)”

Revise “Stage 2” (A) of Detail BD-08 to read:

“Remove the HMA surface mix and crushed stone, the existing pavement shall be sawcut square and full depth a minimum of 1 ft from the rim of the frame to provide vertical faces at the edge of the patch”

Basis of Payment. This work will be paid for at the contract unit price per EACH for FRAMES AND LIDS TO BE ADJUSTED, SPECIAL.

MODIFIED URETHANE PAVEMENT MARKING – RAISED MEDIAN

Description. This work shall consist of removing existing median pavement marking and applying modified urethane pavement markings in accordance with Sections 780 and 783 of the Standard Specifications, except as modified herein, to the median ramped noses as shown in the plans or as directed by the Engineer.

Construction Requirements. The shotblast method of cleaning shall not be permitted.

Method of Measurement. This work will be measured for payment in place and the area computed in square feet based on the area of installed material. The area measured will include applications to concrete curb and gutter monolithic to the median ramped noses.

Basis of Payment. This work will be paid for at the contract unit price per square foot for MODIFIED URETHANE PAVEMENT MARKING – RAISED MEDIAN, which price shall include all necessary equipment, labor and materials required to remove the existing median pavement markings, prepare the surface, and install the pavement markings.

PATH REMOVAL

Description. This work shall consist of removing HMA or Aggregate path pavement and excavating existing subbase or subgrade to the proper depth in order for PCC Sidewalk, 5” to be placed. All work shall be according to the applicable portions of Section 440 of the Standard Specifications and as stated herein.

Construction Requirements. The existing subbase or subgrade shall be excavated to a depth sufficient enough to allow for the placement of Subbase Granular Material, Type B 2” and PCC Sidewalk, 5”.

Basis of Payment. This work will be paid for at the contract unit price per SQ YD for PATH REMOVAL, which price shall be payment in full for all labor, equipment, and materials necessary to complete the work as specified.

RECESSED REFLECTIVE PAVEMENT MARKERS

Description. This work shall consist of setting reflective pavement markers in a recessed groove in the pavement. The recessed pavement markers shall be used to supplement other pavement markings, similar to the use of Raised Reflective Pavement Markers.

Materials. The reflective pavement marker shall be listed on the Illinois Department of Transportation approved list of snowplowable raised pavement markers, or Engineer approved equivalent, and be compatible with the reflector holder. The reflector holder shall be a MarkerOne Series R100 reflector holder or Engineer approved equivalent. The epoxy used shall be as recommended by the pavement marker manufacturer.

Installation. Spacing and orientation of the pavement markers shall be as detailed in the plans or as directed by the Engineer. The recessed groove shall be a maximum of 2" from the adjacent pavement marking, or straight in line with lane lines. The recessed groove shall be straight, with lateral deviation of any individual groove 1" or less.

A recessed groove shall be cut in the pavement 5.25" wide, 0.9" deep on a 15.5" diameter. An additional 3.5' long groove shall taper from 0" (normal pavement) to 0.3" depth (full-recessed).

The recessed area shall be cleaned free of all loose material, and dry before the placement of the pavement marker. All excess material resulting from the construction of the recessed area shall be completely removed from the surface of the roadway by means of vacuum sweeper truck. The pavement marker shall be cemented with epoxy in the center of the 0.9" deep recessed groove.

Inspection. A straight edge shall be placed across the recess to check that the top of the marker is below the pavement. Inspection and acceptance shall be according to Article 781.04 of the Standard Specifications.

Basis of Payment. This work will be paid for at the contract unit price per EACH for RECESSED REFLECTIVE PAVEMENT MARKER.

SIDEWALK REMOVAL AND REPLACEMENT

Description. This work shall consist of the removal of existing sidewalk and replacing it in kind. All work shall be according to the applicable portions of Section 440 and Section 424 of the Standard Specifications and as stated herein.

Construction Requirements. The new sidewalk shall have a minimum thickness of 5". Removal of additional material to provide 5" thickness will not be paid separately but included in the cost of the item. Unsuitable sub-base material shall be removed as directed by the Engineer and replaced either with Sub-Base Granular Material Type B or additional thickness of concrete.

The repair or replacement of any curb and gutter, driveway pavement, or landscaping damaged, disturbed or requiring re-grading within 2 feet of the edge of the sidewalk in order to complete the work will not be paid for separately, but included in the cost of the work. Any required grading and restoration beyond 2 feet shall be paid for at the contract unit price for Removal and Disposal of Unsuitable Material, Top Soil Furnish and Place, 6in, Seeding Class 2A, and Erosion Control Blanket. Any saw cuts necessary to complete the work will not be paid separately, but included in the cost of the item.

Framing and base preparation shall be complete a minimum of four (4) working hours prior to the scheduled arrival of concrete to allow time for inspection.

The locations of sidewalk removal and replacement will be determined by the Engineer in the field.

Basis of payment. This work will be paid for at the contract unit price per SQUARE FOOT for PORTLAND CEMENT CONCRETE SIDEWALK REMOVAL and the contract unit price per SQUARE FOOT for PORTLAND CEMENT CONCRETE SIDEWALK, 5 INCH.

TEMPORARY STONE

Description. This work shall consist of furnishing, placing, salvaging, and maintaining aggregate for temporary roads and approaches as shown on the plans or as directed by the Engineer. The Engineer may require Temporary Stone to be relocated for use at more than one location.

Materials. The material for this item shall be restricted to CA-1, CA-5, or CA-6.

Maintenance. The Contractor shall be required to maintain the Temporary Stone to the satisfaction of the Engineer during the construction period.

Salvage. The Contractor shall, when required by the Engineer or the sequence of operations, salvage for re-use at the same or other locations within the limits of construction, previously placed Temporary Stone.

Basis of Payment. This work will be paid for at the contract unit price per TON (metric ton) for TEMPORARY STONE. The contract unit price shall include all equipment, labor and materials necessary to complete this work as specified including the cost of removing and disposing of the material used for Temporary Stone.

TRAFFIC CONTROL AND PROTECTION

Description. The traffic control and protection for this project shall be performed in accordance with the project Traffic Control Plan and Section 701 of the Standard Specifications as amended by the Special Provision for Work Zone Traffic Control (Illinois Department of Transportation Check Sheet #LRS 3).

The furnishing, placing, and removal of material, or any temporary concrete barrier and impact attenuators, not shown on the plans but required in order to meet the drop off requirements, shall be included in the contract unit price for Traffic Control and Protection.

The cost of supplying, erecting, and maintaining barricades, warning lights, and signs will be included in the contract unit price for Traffic Control and Protection.

Method of Measurement. Traffic control will not be measured by location or per Standard.

Basis of Payment. The cost of Traffic Control and Protection provided under the Traffic Control Plan and Section 701 WORK ZONE TRAFFIC CONTROL will be paid for at the contract LUMP SUM price for TRAFFIC CONTROL AND PROTECTION.

TRAFFIC CONTROL PLAN

Traffic Control shall be according to the applicable sections of the Standard Specifications, the Supplemental Specifications, the "Illinois Manual on Uniform Traffic Control Devices for Streets and Highways", any special details and Highway Standards contained in the plans, and the Special Provisions contained herein.

Special attention is called to Article 107.09 of the Standard Specifications and the following Highway Standards, Details, Quality Standard for Work Zone Traffic Control Devices, Recurring Special Provisions and Special Provisions contained herein, relating to traffic control.

The Contractor shall notify the Engineer at least 72 hours in advance of beginning work.

STANDARDS:

- 701101 Off-Road Operations, Multilane, 15' to 24" From Pavement Edge
- 701301 Lane Closure, 2L, 2W, Short Time Operations
- 701421 Lane Closure, Multilane, Day Operations Only, For Speeds ≥ 45 mph to 55 mph
- 701427 Lane Closure, Multilane, Intermittent or Moving Operations, for speeds ≤ 40 MPH
- 701456 Partial Exit Ramp Closure, Freeway/Expressway
- 701501 Urban Lane Closure 2L, 2W, Undivided
- 701502 Urban Lane Closure, 2L, 2W, with Bidirectional Left Turn Lane
- 701601 Urban Lane Closure, Multilane, 1W or 2W with NonTraversable Median
- 701602 Urban Lane Closure Multilane, 2W with Bidirectional Left Turn Lane
- 701606 Urban Lane Closure, 2W with Mountable Median
- 701611 Urban Half Road Closure, Multilane, 2W, with Mountable Median
- 701701 Urban Lane Closure, Multilane Intersection
- 701801 Sidewalk, Corner or Crosswalk Closure
- 701901 Traffic Control Devices

DETAILS:

- TC 10 Traffic Control and Protection for side Roads, Intersections, and Driveways
- TC 14 Traffic Control and Protection at Turn Bays (To Remain Open)
- TC 16 Pavement Markings Letters and Symbols for Traffic Staging

SPECIAL PROVISIONS:

- SECTION 703 WORK ZONE PAVEMENT MARKING
- TRAFFIC CONTROL AND PROTECTION
- PUBLIC CONVIENIENCE AND SAFETY (D-1)
- VEHICLE AND EQUIPMENT WARNING LIGHTS (BDE)
- WORK ZONE TRAFFIC CONTROL DEVICES (BDE)

FRICITION AGGREGATE (D-1)

Effective: January 1, 2011
Revised: December 1, 2021

Revise Article 1004.03(a) of the Standard Specifications to read:

“1004.03 Coarse Aggregate for Hot-Mix Asphalt (HMA). The aggregate shall be according to Article 1004.01 and the following.

(a) Description. The coarse aggregate for HMA shall be according to the following table.

Use	Mixture	Aggregates Allowed
Class A	Seal or Cover	<u>Allowed Alone or in Combination</u> ^{5/} : Gravel Crushed Gravel Carbonate Crushed Stone Crystalline Crushed Stone Crushed Sandstone Crushed Slag (ACBF) Crushed Steel Slag Crushed Concrete
HMA Low ESAL	Stabilized Subbase or Shoulders	<u>Allowed Alone or in Combination</u> ^{5/} : Gravel Crushed Gravel Carbonate Crushed Stone Crystalline Crushed Stone Crushed Sandstone Crushed Slag (ACBF) Crushed Steel Slag ^{1/} Crushed Concrete
HMA High ESAL Low ESAL	Binder IL-19.0 or IL-19.0L SMA Binder	<u>Allowed Alone or in Combination</u> ^{5/ 6/} : Crushed Gravel Carbonate Crushed Stone ^{2/} Crystalline Crushed Stone Crushed Sandstone Crushed Slag (ACBF) Crushed Concrete ^{3/}

2022 PAVEMENT MAINTENANCE
NORTH REGION
SEC. 22-PVMTTC-17-GM

Use	Mixture	Aggregates Allowed								
HMA High ESAL Low ESAL	C Surface and Binder IL-9.5 IL-9.5FG or IL-9.5L	<u>Allowed Alone or in Combination</u> ^{5/} : Crushed Gravel Carbonate Crushed Stone ^{2/} Crystalline Crushed Stone Crushed Sandstone Crushed Slag (ACBF) Crushed Steel Slag ^{4/} Crushed Concrete ^{3/}								
HMA High ESAL	D Surface and Binder IL-9.5 or IL-9.5FG	<u>Allowed Alone or in Combination</u> ^{5/} : Crushed Gravel Carbonate Crushed Stone (other than Limestone) ^{2/} Crystalline Crushed Stone Crushed Sandstone Crushed Slag (ACBF) Crushed Steel Slag ^{4/}								
		<u>Other Combinations Allowed:</u>								
		<table border="1" style="width: 100%;"> <tr> <td style="width: 50%;"><i>Up to...</i></td> <td style="width: 50%;"><i>With...</i></td> </tr> <tr> <td>25% Limestone</td> <td>Dolomite</td> </tr> <tr> <td>50% Limestone</td> <td>Any Mixture D aggregate other than Dolomite</td> </tr> <tr> <td>75% Limestone</td> <td>Crushed Slag (ACBF) or Crushed Sandstone</td> </tr> </table>	<i>Up to...</i>	<i>With...</i>	25% Limestone	Dolomite	50% Limestone	Any Mixture D aggregate other than Dolomite	75% Limestone	Crushed Slag (ACBF) or Crushed Sandstone
		<i>Up to...</i>	<i>With...</i>							
		25% Limestone	Dolomite							
50% Limestone	Any Mixture D aggregate other than Dolomite									
75% Limestone	Crushed Slag (ACBF) or Crushed Sandstone									
HMA High ESAL	E Surface IL-9.5 SMA Ndesign 80 Surface	<u>Allowed Alone or in Combination</u> ^{5/ 6/} : Crushed Gravel Crystalline Crushed Stone Crushed Sandstone Crushed Slag (ACBF) Crushed Steel Slag No Limestone.								
		<u>Other Combinations Allowed:</u>								
		<table border="1" style="width: 100%;"> <tr> <td style="width: 50%;"><i>Up to...</i></td> <td style="width: 50%;"><i>With...</i></td> </tr> <tr> <td>50% Dolomite^{2/}</td> <td>Any Mixture E aggregate</td> </tr> </table>	<i>Up to...</i>	<i>With...</i>	50% Dolomite ^{2/}	Any Mixture E aggregate				
<i>Up to...</i>	<i>With...</i>									
50% Dolomite ^{2/}	Any Mixture E aggregate									

2022 PAVEMENT MAINTENANCE
NORTH REGION
SEC. 22-PVMTTC-17-GM

Use	Mixture	Aggregates Allowed	
		75% Dolomite ^{2/}	Crushed Sandstone, Crushed Slag (ACBF), Crushed Steel Slag, or Crystalline Crushed Stone
		75% Crushed Gravel ^{2/}	Crushed Sandstone, Crystalline Crushed Stone, Crushed Slag (ACBF), or Crushed Steel Slag
HMA High ESAL	F Surface IL-9.5 SMA Ndesign 80 Surface	<u>Allowed Alone or in Combination</u> ^{5/ 6/} :	
		Crystalline Crushed Stone Crushed Sandstone Crushed Slag (ACBF) Crushed Steel Slag No Limestone.	
		<u>Other Combinations Allowed:</u>	
		<i>Up to...</i>	<i>With...</i>
		50% Crushed Gravel ^{2/} or Dolomite ^{2/}	Crushed Sandstone, Crushed Slag (ACBF), Crushed Steel Slag, or Crystalline Crushed Stone

- 1/ Crushed steel slag allowed in shoulder surface only.
- 2/ Carbonate crushed stone (limestone) and/or crushed gravel shall not be used in SMA Ndesign 80.
- 3/ Crushed concrete will not be permitted in SMA mixes.
- 4/ Crushed steel slag shall not be used as binder.
- 5/ When combinations of aggregates are used, the blend percent measurements shall be by volume.”
- 6/ Combining different types of aggregate will not be permitted in SMA Ndesign 80.”

HOT-MIX ASPHALT BINDER AND SURFACE COURSE (D-1)

Effective: November 1, 2019
 Revised: December 1, 2021

Revise Article 1004.03(c) to read:

“(c) Gradation. The coarse aggregate gradations shall be as listed in the following table.

Use	Size/Application	Gradation No.
Class A-1, A-2, & A-3	3/8 in. (10 mm) Seal	CA 16 or CA 20
Class A-1	1/2 in. (13 mm) Seal	CA 15
Class A-2 & A-3	Cover Coat	CA 14
HMA High ESAL	IL-19.0; Stabilized Subbase IL-19.0	CA 11 ^{1/}
	SMA 12.5 ^{2/}	CA 13 ^{4/} , CA 14, or CA 16
	SMA 9.5 ^{2/}	CA 13 ^{3/4/} or CA 16 ^{3/}
	IL-9.5	CA 16, CM 13 ^{4/}
	IL-9.5FG	CA 16
HMA Low ESAL	IL-19.0L	CA 11 ^{1/}
	IL-9.5L	CA 16

1/ CA 16 or CA 13 may be blended with the CA 11.

2/ The coarse aggregates used shall be capable of being combined with the fine aggregates and mineral filler to meet the approved mix design and the mix requirements noted herein.

3/ The specified coarse aggregate gradations may be blended.

4/ CA 13 shall be 100 percent passing the 1/2 in. (12.5mm) sieve.”

Revise Article 1004.03(e) of the Supplemental Specifications to read:

“(e) Absorption. For SMA the coarse aggregate shall also have water absorption
 ≤ 2.0 percent.”

Revise the “High ESAL” portion of the table in Article 1030.01 to read:

“High ESAL	Binder Courses	IL-19.0, IL-9.5, IL-9.5FG, IL-4.75, SMA 12.5, Stabilized Subbase IL-19.0
	Surface Courses	IL-9.5, IL-9.5FG, SMA 12.5, SMA 9.5”

Revise Note 2. and add Note 6 to Article 1030.02 of the Standard Specifications to read:

“Item	Article/Section
(g)Performance Graded Asphalt Binder (Note 6)	1032
(h)Fibers (Note 2)	

Note 2. A stabilizing additive such as cellulose or mineral fiber shall be added to the SMA mixture according to Illinois Modified AASHTO M 325. The stabilizing additive shall meet the Fiber Quality Requirements listed in Illinois Modified AASHTO M 325. Prior to approval and use of fibers, the Contractor shall submit a notarized certification by the producer of these materials stating they meet these requirements. Reclaimed Asphalt Shingles (RAS) may be used in Stone Matrix Asphalt (SMA) mixtures designed with an SBA polymer modifier as a fiber additive if the mix design with RAS included meets AASHTO T305 requirements. The RAS shall be from a certified source that produces either Type I or Type 2. Material shall meet requirements noted herein and the actual dosage rate will be determined by the Engineer.

Note 6. The asphalt binder shall be an SBS PG 76-28 when the SMA is used on a full-depth asphalt pavement and SBS PG 76-22 when used as an overlay, except where modified herein. The asphalt binder shall be a SBS PG 76-22 for IL-4.75, except where modified herein..”

Revise table in Article 1030.05(a) of the Standard Specifications to read:

"MIXTURE COMPOSITION (% PASSING) ^{1/}												
Sieve Size	IL-19.0 mm		SMA 12.5		SMA 9.5		IL-9.5mm		IL-9.5FG		IL-4.75 mm	
	min	max	min	max	min	max	min	max	min	max	min	max
1 1/2 in (37.5 mm)												
1 in. (25 mm)		100										
3/4 in. (19 mm)	90	100		100								
1/2 in. (12.5 mm)	75	89	80	100		100		100		100		100
3/8 in. (9.5 mm)				65	90	100	90	100	90	100		100
#4 (4.75 mm)	40	60	20	30	36	50	34	69	60	75 ^{6/}	90	100
#8 (2.36 mm)	20	42	16	24 ^{4/}	16	32 ^{4/}	34 ^{5/}	52 ^{2/}	45	60 ^{6/}	70	90
#16 (1.18 mm)	15	30					10	32	25	40	50	65
#30 (600 μm)			12	16	12	18			15	30		
#50 (300 μm)	6	15					4	15	8	15	15	30
#100 (150 μm)	4	9					3	10	6	10	10	18
#200 (75 μm)	3.0	6.0	7.0	9.0 ^{3/}	7.5	9.5 ^{3/}	4.0	6.0	4.0	6.5	7.0	9.0 ^{3/}
#635 (20 μm)			≤ 3.0		≤ 3.0							
Ratio Dust/Asphalt Binder		1.0		1.5		1.5		1.0		1.0		1.0

1/ Based on percent of total aggregate weight.

2/ The mixture composition shall not exceed 44 percent passing the #8 (2.36 mm) sieve for surface courses with N_{design} = 90.

3/ Additional minus No. 200 (0.075 mm) material required by the mix design shall be mineral filler, unless otherwise approved by the Engineer.

4/ When establishing the Adjusted Job Mix Formula (AJMF) the percent passing the #8 (2.36 mm) sieve shall not be adjusted above the percentage stated on the table.

5/ When establishing the Adjusted Job Mix Formula (AJMF) the percent passing the #8 (2.36 mm) sieve shall not be adjusted below 34 percent.

6/ When the mixture is used as a binder, the maximum shall be increased by 0.5 percent passing."

Revise Article 1030.05(b) of the Standard Specifications to read:

- (b) Volumetric Requirements. The target value for the air voids of the HMA shall be 4.0 percent, for IL-4.75 and SMA mixtures it shall be 3.5 percent and for Stabilized Subbase it shall be 3.0 percent at the design number of gyrations. The voids in the mineral aggregate (VMA) and voids filled with asphalt binder (VFA) of the HMA design shall be based on the nominal maximum size of the aggregate in the mix and shall conform to the following requirements.

Mix Design	Voids in the Mineral Aggregate (VMA), % Minimum for Ndesign				
	30	50	70	80	90
IL-19.0		13.5	13.5		13.5
IL-9.5		15.0	15.0		
IL-9.5FG		15.0	15.0		
IL-4.75 ^{1/}		18.5			
SMA-12.5 ^{1/2/5/}				17.0 ^{3/} /16.0 ^{4/}	
SMA-9.5 ^{1/2/5/}				17.0 ^{3/} /16.0 ^{4/}	
IL-19.0L	13.5				
IL-9.5L	15.0				

- 1/ Maximum draindown shall be 0.3 percent according to Illinois Modified AASHTO T 305.
- 2/ The draindown shall be determined at the JMF asphalt binder content at the mixing temperature plus 30°F.
- 3/ Applies when specific gravity of coarse aggregate is ≥ 2.760 .
- 4/ Applies when specific gravity of coarse aggregate is < 2.760 .
- 5/ For surface course, the coarse aggregate can be crushed steel slag, crystalline crushed stone or crushed sandstone. For binder course, coarse aggregate shall be crushed stone (dolomite), crushed gravel, crystalline crushed stone, or crushed sandstone”

Revise the last paragraph of Article 1102.01 (a) (5) of the Standard Specifications to read:

“IL-4.75 and Stone Matrix Asphalt (SMA) mixtures which contain aggregate having absorptions greater than or equal to 2.0 percent, or which contain steel slag sand, shall have minimum surge bin storage plus haul time of 1.5 hours.”

Add after third sentence of Article 1030.09(b) to read:

“ If the Contractor and Engineer agree the nuclear density test method is not appropriate for the mixture, cores shall be taken at random locations determined according to the QC/QA document "Determination of Random Density Test Site Locations". Core densities shall be determined using the Illinois Modified AASHTO T 166 or T 275 procedure.”

Revise Table 1 and Note 4/ of Table 1 in Article 406.07(a) of the Standard Specifications to read:

	Breakdown/Intermediate Roller (one of the following)	Final Roller (one or more of the following)	Density Requirement
IL-9.5, IL-9.5FG, IL-19.0 ^{1/}	V _D , P, T _B , 3W, O _T , O _B	V _S , T _B , T _F , O _T	As specified in Section 1030
IL-4.75 and SMA ^{3/} _{4/}	T _B , 3W, O _T	T _F , 3W	As specified in Section 1030
Mixtures on Bridge Decks ^{2/}	T _B	T _F	As specified in Articles 582.05 and 582.06.

“4/ The Contractor shall provide a minimum of two steel-wheeled tandem rollers (T_B), and/or three-wheel (3W) rollers for breakdown, except one of the (T_B) or (3W) rollers shall be 84 inches (2.14 m) wide and a weight of 315 pound per linear inch (PLI) (5.63 kg/mm) and one of the (T_B) or (3W) rollers can be substituted for an oscillatory roller (O_T). T_F rollers shall be a minimum of 280 lb/in. (50 N/mm). The 3W and T_B rollers shall be operated at a uniform speed not to exceed 3 mph (5 km/h), with the drive roll for T_B rollers nearest the paver and maintain an effective rolling distance of not more than 150 ft (45 m) behind the paver.”

Add the following after the fourth paragraph of Article 406.13 (b):

“The plan quantities of SMA mixtures shall be adjusted using the actual approved binder and surface Mix Design’s G_{mb}.”

Revise first paragraph of Article 1030.10 of the Standard Specifications to read:

“A test strip of 300 ton (275 metric tons), except for SMA mixtures it will be 400 ton (363 metric ton), will be required for each mixture on each contract at the beginning of HMA production for each construction year according to the Manual of Test Procedures for Materials “Hot Mix Asphalt Test Strip Procedures”. At the request of the Producer, the Engineer may waive the test strip if previous construction during the current construction year has demonstrated the constructability of the mix using Department test results.”

Revise third paragraph of Article 1030.10 of the Standard Specifications to read:

“When a test strip is constructed, the Contractor shall collect and split the mixture according to the document “Hot-Mix Asphalt Test Strip Procedures”. The Engineer, or a representative, shall deliver split sample to the District Laboratory for verification testing. The Contractor shall complete mixture tests stated in Article 1030.09(a). Mixture sampled shall include enough material for the Department to conduct mixture tests detailed in Article 1030.09(a) and in the document “Hot-Mix Asphalt Mixture Design Verification Procedure” Section 3.3. The mixture test results shall meet the requirements of Articles 1030.05(b) and 1030.05(d), except Hamburg wheel tests will only be conducted on High ESAL mixtures during production.”

HOT-MIX ASPHALT – MIXTURE DESIGN VERIFICATION AND PRODUCTION (D-1)

Effective: January 1, 2019
Revised: December 1, 2021

Add to Article 1030.05 (d)(3) of the Standard Specifications to read:

“During mixture design, prepared samples shall be submitted to the District laboratory by the Contractor for verification testing. The required testing, and number and size of prepared samples submitted, shall be according to the following tables.

High ESAL – Required Samples for Verification Testing	
Mixture	Hamburg Wheel and I-FIT Testing ^{1/2/}
Binder	total of 3 - 160 mm tall bricks
Surface	total of 4 - 160 mm tall bricks

Low ESAL – Required Samples for Verification Testing	
Mixture	I-FIT Testing ^{1/2/}
Binder	1 - 160 mm tall brick
Surface	2 - 160 mm tall bricks

- 1/ The compacted gyratory bricks for Hamburg wheel and I-FIT testing shall be 7.5 ± 0.5 percent air voids.
- 2/ If the Contractor does not possess the equipment to prepare the 160 mm tall brick(s), twice as many 115 mm tall compacted gyratory bricks will be acceptable.

Revise the fourth paragraph of Article 1030.10 of the Standard Specifications to read:

“When a test strip is not required, each HMA mixture shall still be sampled on the first day of production: I-FIT and Hamburg wheel testing for High ESAL; I-FIT testing for Low ESAL. Within two working days after sampling the mixture, the Contractor shall deliver gyratory cylinders to the District laboratory for Department verification testing. The High ESAL mixture test results shall meet the requirements of Articles 1030.05(d)(3) and 1030.05(d)(4). The Low ESAL mixture test results shall meet the requirements of Article 1030.05(d)(4). The required number and size of prepared samples submitted for the Hamburg wheel and I-FIT testing shall be according to the “High ESAL - Required Samples for Verification Testing” table in Article 1030.05(d)(3) above.”

Add the following to the end of Article 1030.10 of the Standard Specifications to read:

“Mixture sampled during first day of production shall include approximately 60 lb (27 kg) of additional material for the Department to conduct Hamburg wheel testing and approximately 80 lb (36 kg) of additional material for the Department to conduct I-FIT testing. Within two working days after sampling, the Contractor shall deliver prepared samples to the District laboratory for verification testing. The required number and size of prepared samples submitted for the Hamburg wheel and I-FIT testing shall be according to the “High ESAL - Required Samples for Verification Testing” table in Article 1030.05(d)(3) above.”

PUBLIC CONVIENIENCE AND SAFETY (D-1)

Effective: May 1, 2012

Revised: July 15, 2012

Add the following to the end of the fourth paragraph of Article 107.09:

“If the holiday is on a Saturday or Sunday, and is legally observed on a Friday or Monday, the length of Holiday Period for Monday or Friday shall apply.”

Add the following sentence after the Holiday Period table in the fourth paragraph of Article 107.09:

“The Length of Holiday Period for Thanksgiving shall be from 5:00 AM the Wednesday prior to 11:59 PM the Sunday After”

Delete the fifth paragraph of Article 107.09 of the Standard Specifications:

“On weekends, excluding holidays, roadways with Average Daily Traffic of 25,000 or greater, all lanes shall be open to traffic from 3:00 P.M. Friday to midnight Sunday except where structure construction or major rehabilitation makes it impractical.”

RAILROAD FLAGGING

The cost incurred by the Department per Article 107.12 of the Standard Specifications shall be paid by the contractor.

The Railroad may require an Agreement/Permit in order for the Contractor to work on the Railroad's Right-Of-Way. The Contractor shall apply for any required Agreement and/or Permit and pay any fees charged by the Railroad.

The Department will reimburse the Contractor the actual costs of Agreement/Permit fees and Railroad Flagging fees up to a maximum of 10 calendar days per railroad crossing without additional profit, overhead, or administrative costs. Cost of Railroad Flagging in excess of 10 calendar days per railroad crossing will not be reimbursed to the Contractor.

The pay item RAILROAD FLAGGING has been established for the reimbursement of Railroad Flagging and Agreement/Permit fees. This item is not a bid item, but is included in the proposal as part of the project costs.

CN Request for Flagging Services and Cable Location

Project Information:	
Please fill in each cell for processing	
Is this a new project?	
List CN Project # (Example SO# 123456, Network# R1234, PSC-132):	
Contractor's Right of Entry (ROE), License, Permit #:	
Date of Agreement for ROE, License or Permit:	
Termination Date of Agreement for ROE, License or Permit (If Applicable):	
Does the scope of work include underground, piledriving, excavation or other activities which would require a Railroad Cable Locate? Note: railroad cables and fibers are not part of any state utility locate programs. If a contractor shows up on site to perform work that requires a cable locate and it was not requested, the flagger will shut down the project	
Does your project require vehicular traffic to be shifted out of its intended lane against the current of traffic at a railroad grade crossing?	
Railroad Subsidiary (listed on your agreement):	
<p>Licensee and/or their contractor shall request, prepay, and secure Railroad Company signal facility locates by written notice to Railroad Company along with submission of CN's "Request for Flagging Services" form at least, 10 business days in advance of proposed performance of any work or access to Railroad Company property. Notice to Railroad Company does not fulfill or satisfy any other notification requirements for utility locates for non-railroad facilities.</p> <p><i>You must have an agreement with a CN railroad subsidiary, such as a Right of Entry, Permit, License or Formal Agreement in addition to any necessary flagging before you may enter CN property.</i></p>	
Flagging Protection Schedule:	
Requested Dates for Flagger Protection: Dates requested are subject to Flagging Co. availability and any project needing a cable locate will need 10 days minimum advance notice. This should be considered when requesting dates for flagging.	
Estimated Duration (in days) for Flagger:	
Estimated Work Schedule (example Mon. – Sat.)	
Daily Start Time / End Time (example 0700 to 1700 etc.): (Flagger start and end time may vary based on type of protection required)	
Flagging Protection Location:	
Railroad Mile Post (MP):	
Railroad Subdivision:	
Project's Location (Street location/intersection):	
Project - City / State:	
Project Description (example HDD, Jack and Bore, Encroachment, Underground or Overhead Pipeline / Wireline crossing, etc.):	
Location for flagger to report:	
Field Contact Person(s):	1 st Alternate
Mobile Phone Number(s):	1 st Alternate
Email Address(s):	

CN REQUEST FOR FLAGGING SERVICES AND CABLE LOCATION

Billing Information:

Company Name:	
Contact Name:	
E-Mail:	
Billing Address:	
City/State:	
ZIP Code:	
Company Phone:	

Electronic Payment Instructions		Payment Information	
Financial Institution	HARRIS TRUST AND SAVINGS BANK 311 WEST MONROE, CHICAGO, IL	Customer Number (if available)	
Account Name	Grand Trunk Western	CN Contact	
Account	274-733-5	Service Requested (Flagging MP, Request Date)	
US ROUTING (ABA)	071 000 288		
Remittance Details	nfcashmanagement@cn.ca	Prepayment Amount	

Please send payment remittance details and copy of this flagging request to nfcashmanagement@cn.ca

Before Flagging Service is provided:

CN required online training must be completed before Flagging Protection will be scheduled.
Prepayment must be received before Flagging Protection will be scheduled.
There is an 8-hour minimum per day. The base rate for Flagging Protection is \$1,300 for 10 hours: this includes 2 overtime hours for flagger to set up/take down protection if needed. Additional overtime hour must be prepaid at the rate of \$150.00 per hour. Weekends and Holidays must be prepaid at the overtime rate with a \$1,500.00 / 10 hour minimum. (Rates Effective January 1st, 2021.)
If additional days of flagging protection are required, they must be prepaid in advance.
Any prepayment not used can be refunded.
Railroad Cable Location must be prepaid, the cost is \$350.00 per locate.

This completed form must be sent with a map, confirmation of electronic prepayment, and proof of insurance to US_Flagging@cn.ca

CN Flagging Department

US Flagging
 T: 248-914-9695
 17641 South Ashland Ave.
 Homewood, IL 60430
US_Flagging@cn.ca

I, _____, agree to pay for flagging and/or cable locate services as requested _____
Print Name
Signature



Manager Public Works

Thomas L. Brasseur

700 Pershing Rd

Pontiac, MI 48340

T 715-544-9145

F 248-452-4783

Email: thomas.brasseur@cn.ca

Right of Entry (ROE) License Agreement Information

Railroad Company requires everyone (contractor, consultants, etc.) working on Railroad Company property to have a Right-of-Entry (ROE) License Agreement. No work may occur on Railroad Company property nor will flagging protection be provided until ROE License Agreement has been fully executed by both parties and returned.

Follow these steps to obtain a ROE:

1. Applicant will **Email** this completed application to thomas.brasseur@cn.ca
2. Applicant will **mail** a check for the application fee \$1000.00* to the address listed at the end of this document
3. Applicant will **Email** a COI (Certificate of Insurance) meeting the requirements outlined in the Insurance requirements section of this document
4. Once steps 1-3 are completed, the Railroad Company will begin processing the ROE application
5. If approved, the Applicant will receive an electronic copy of the ROE agreement by email
6. Applicant will have the ROE agreement executed by Applicant's VP or president of Applicant's company
7. Applicant will return a **HARD COPY** of the partially executed ROE agreement by mail to the Railroad Company address listed at the end of this document
8. The Railroad Company will return a fully executed digital copy of the ROE License Agreement by email for the Applicants records.

Please use this form and return by email to submit application request for a Right of Entry agreement.

Contact name and Email address –

Name of Applicant/contractor and email address -

Street Address –

City, State, Zip –

Telephone –

Detailed Purpose for ROE –

Start and Completion Date of ROE –

Public Agency's Project No. –

Public Agency Easement No. (if known) –

Location of project –

Subdivision and Milepost –

FRA/AAR/DOT Crossing No. and Name –
(Nearest to jobsite)

If unable to locate this number at jobsite, please use following links to obtain:

<http://safetydata.fra.dot.gov/officeofsafety/publicsite/crossing/xingqryloc.aspx>

In Illinois

<http://www.icc.illinois.gov/railroad/advanced.aspx?>

Please attach an aerial snapshot and a Google Earth kmz file to help identify specific location.

FAQ

What time frame can I expect to begin work and have flagging protection for my work?

A **Right of Entry License Agreement usually takes 4 to 6 weeks to obtain**. Once you have a fully executed ROE agreement, you will receive a flagging request form. This flagging request form along with prepayment for flagging fees will need to be *mailed to the physical address listed on the flagging request form*. Once this flagging request form is received, it is usually about **10 days until a flagger can be scheduled**. These are normal time frames. **Time frames can vary substantially** based on many factors. Expedited time frames may be able to be requested at an additional fee.

A brief summary of time frame for each step toward obtaining flagging protection...

1. Right of Entry License Agreement usually takes **4 to 6 weeks to obtain**.
2. Send in flagging check and flagging request form...about **1 week**
3. Once this flagging request form is received, it is usually about **10 days** until a flagger can be scheduled

What are the insurance requirements?

Railroad Company allows outside parties to come onto Railroad Company property to perform work, such as survey or inspection work, installation of pipelines and wirelines, and other work for projects necessitating the occupancy of Railroad Company. Before commencing work, and until the license of allowing such occupancy ends or is terminated, outside parties shall provide and maintain the following insurance in form and amount with companies satisfactory to and as approved by Railroad Company.

1. Minimum insurance required of outside party:
 - A. Statutory Workers Compensation and Employer's Liability Insurance.
 - B. Automobile Liability Insurance in an amount not less than \$1,000,000 combined single limit.
 - C. Commercial General Liability Insurance (Occurrence Form) in an amount not less than **\$5,000,000 per occurrence, with an aggregate limit of not less than \$10,000,000**. The policy must name Railroad Company and its Parents as additional insureds in the following form:

Chicago, Central & Pacific Railroad Company and its Parents
Attn: Thomas L. Brasseur
700 Pershing Rd
Pontiac, MI 48340
715-544-9145
thomas.brasseur@cn.ca

The policy must remove any provisions excluding coverage for injury, loss or damage arising out of or resulting from doing business or undertaking construction or demolition on, near, or adjacent to railroad track or facilities using endorsement CG 2417 10 01 or equivalent approved by Railroad Company.

- D. When outside party is required by Railroad Company or Governing Authority to purchase Railroad Protective Liability Insurance to cover work on, near or adjacent to railroad track or facilities, and outside party is not being hired for this project by Railroad Company, outside party must procure Railroad Protective Liability Insurance in the following form;

This coverage shall be written on an Occurrence Form with limits of not less than \$5,000,000 per occurrence for Bodily Injury, Personal Injury and Physical Damage to Property, with an aggregate limit of not less than \$10,000,000. The policy must name:

Chicago, Central & Pacific Railroad Company and its Parents
Attn: Thomas L. Brasseur
700 Pershing Rd
Pontiac, MI 48340
715-544-9145
thomas.brasseur@cn.ca

- E. In the event the privileges provided herein to Applicant involve any work that could result in the discharge, spillage, disposal, release or escape of any Hazardous Material or petroleum product onto the Railroad Company's property, Applicant shall purchase and maintain in effect at all times during the term of this License a Contractor's Pollution Liability policy in an amount not less than two million dollars (\$2,000,000) combined single limit (and with a deductible not to exceed \$50,000) insuring Railroad against any and all damages, costs, liabilities and expenses resulting from on- or off-site bodily injury (including death to any person), on or off-site loss, damage or destruction of property (including that belonging to the parties hereto), and on-or off-site cleanup costs (including expenses incurred in the investigation, removal, remediation, neutralization, or immobilization of contaminated soils, surface water, groundwater or any other contamination) growing out of or incidental to any discharge, spillage, disposal, release, or escape of any Hazardous Material or petroleum product arising therefrom. For purposes of this Agreement, the term "Hazardous Material" shall include, without limit, any flammable explosives, radioactive materials, hazardous materials, hazardous wastes, hazardous or toxic substances, or related materials defined in the Comprehensive Environmental Response, Compensation and Liability Act of 1980, as amended (42 U.S.C. §§ 9601, et seq.), the Hazardous Material Transportation Act, as amended (49 U.S.C. §§ 1801, et seq.), the Resource Conservation and Recovery Act, as amended (42 U.S.C. §§ 6901 et seq.), the Toxic Substances Control Act, as amended (15 U.S.C. §§ 2601, et seq.), similar laws or ordinances enacted by any state, county or municipality in which the Property is located, or in the regulations adopted and publications promulgated pursuant to any of the above, as such laws or regulations now exist or may exist in the future.

Applicant is required to advise Railroad Company by thirty (30) day advance written notice when any work to be performed under this License may require Pollution Liability Insurance pursuant to the previous paragraph.

- F. All policies described above must include description of operations, Railroad Company milepost, highway or street name, city and state of location, project number, and Railroad Company contact person on the certificate.
2. Before commencing work, outside party shall deliver to Railroad Company a certificate of insurance evidencing the foregoing coverages and, if requested by Railroad Company, true and complete copies of the policies described above. If the policy is being issued in conjunction with, or as a result of, a city, county or state contract, the policy should be initially submitted to the respective city, county or state agency that will review it first and then forward it to Railroad Company.
3. Common Policy Provisions. Each policy described in paragraph 1, parts A through E above, must include the following provisions:
- A. **Each policy shall include a waiver by the insurer of any right of subrogation against any recovery by or on behalf of any insured.**
- B. Each policy shall provide for not less than thirty (30) days prior written notice to Railroad Company at the address listed above of cancellation of or any material change in that policy.

4. It is understood and agreed that the foregoing insurance coverage requirements, and outside party's compliance with those requirements, is not intended to, and shall not, relieve outside party from, or serve to limit, outside party's liability and indemnity obligations under the provisions herein.
5. Railroad Company shall have the right, from time to time, to revise the amount or form of insurance coverage required as circumstances or changing economic conditions may require. Railroad Company shall give outside party written notice of any such requested change at least thirty (30) days before the date of expiration of the then-existing policy or policies, outside party agrees to, and shall, thereupon provide Railroad Company with such revised policy or policies.
6. Insurance required of SUBCONTRACTOR:
 - A. If a SUBCONTRACTOR is to be employed by outside party to perform work on Railroad Company under or by the permission for occupancy granted to outside party by Railroad Company, before commencing work, the SUBCONTRACTOR shall provide and thereafter maintain all of the insurance described in paragraph 1, parts A through E, above, in the same forms and amounts as provided for above and subject to the other terms and conditions provided for in paragraphs 2 through 4 above.
 - B. In the alternative, before the SUBCONTRACTOR commences work for outside party on Railroad Company, outside party may provide and thereafter maintain all of the insurance described in paragraph 1, parts A through E, above, in the same forms and amounts as provided for above and subject to the other terms and conditions provided for in paragraphs 2 through 5 above, provided that all such insurance names SUBCONTRACTOR as an additional insured and all such insurance provides coverage to all additional insureds, including Railroad Company, for any liability arising out of work performed by all other additional insureds, including SUBCONTRACTOR.

Is safety training required?

Prior to any entry onto Railroad Company's property, the employees and/or subcontractors of a Contractor, Grantee, Licensee, or Permittee shall determine by the guidelines hereinafter provided and by the work to be performed the level of safety training to be required.

All employees and/or subcontractors of a Contractor, Grantee, Licensee, or Permittee not hired by Railroad Company that will work on CN property are required to have minimum www.contractororientation.com.

- a. EXCEPTION: Railroad Company has exempted those it classifies as "Delivery Persons" from this training. This will include contractors such as UPS, FedEx, trucking companies, etc. who merely access the property to supply materials or equipment.

All employees and/or subcontractors of a Contractor, Grantee, Licensee, or Permittee hired by Railroad Company which will work on Railroad Company property are required to have minimum CN Safety and Security Awareness training, in addition to undergoing a background check. This training and background check must be obtained through the eRailSafe.com website. If not done before, the contractor must contact e-RailSafe at 855-383-7434 to be issued either a vendor number or issued instructions on obtaining a non –railroad contractor vendor number prior to accessing the noted website. Minimum information required of a Contractor, Grantee, Licensee, or Permittee and/or their subcontractor when contacting e-RailSafe is Name, Address, Telephone, Contact Person for State Projects, DOT Contract Number, and the AAR/DOT Number. This training is good for a period of two years.

- a. EXCEPTION: Railroad Company has exempted those employees of contractors providing paving services at a road crossing under construction or repair from this requirement.
- b. EXCEPTION: Railroad Company has exempted those it classifies as "Delivery Persons" from this training. This will include contractors such as UPS, FedEx, trucking companies, etc. who merely access the property to supply materials or equipment.

All employees and/or subcontractors of a Contractor, Grantee, Licensee, or Permittee hired by Railroad Company, whose duties include and who are engaged in the inspection, construction, maintenance, or repair of railroad track, bridges, roadway, signal and communication systems, roadway facilities, or roadway machinery that will work foul of or have the potential to foul a live track are considered Roadway Workers under FRA regulations and CN Policy. They must complete the On-Track Safety Training course approved by Railroad Company and provided by R.R. Safety – AMR, P.O. Box 75, Lomira, WI 53048, telephone (920) 517-1677, email rrsafetytraining@yahoo.com. This training must be repeated at least once each calendar year.

- a. EXCEPTION: Railroad Company has exempted those employees of contractors providing paving services at a road crossing under construction or repair from this requirement.
- b. EXCEPTION: Railroad Company has exempted those it classifies as "Delivery Persons" from this training. This will include contractors such as UPS, FedEx, trucking companies, etc. who merely access the property to supply materials or equipment.
- c. All the employees and/or subcontractors of a Contractor, Grantee, Licensee, or Permittee who will operate on-track machinery or those who will provide protection for other employees and/or subcontractors of a Contractor, Grantee, Licensee, or Permittee must also be trained on CN US Operating Rules pertaining to their duties. They must take and pass the required examination. This training is good for a period of two years.
- d. "Potential to foul a live track" is considered, at a minimum, to be working within twenty-five (25) feet of the track; or as otherwise to be determined by CN Design & Construction Department.

The employees, subcontractors, and/or agents of the Licensee and/or its contractor shall qualify for, and make available for inspection to Railroad Company's employees or other authorized personnel at all times while on Railroad Company property, a photo identification issued by www.e-railsafe.com, along with at least one other government-issued form of identification. Licensee and/or their contractor shall bear all costs of compliance with the requirements of this Section. Railroad Company reserves the right to bar any of employees or agents of a Contractor, Grantee, Licensee, or Permittee and/or their contractor from Railroad Company's property at any time for any reason.

What are the costs and address to mail documents and ROE application fee check?

Application Fee Information:

Cost is \$1000.00* for application

*Fee may be increased for special handling, expedited handling, or multiple reviews.

Check Payable To: Chicago, Central & Pacific Railroad Company

Mail To: Thomas L. Brasseur
700 Pershing Rd
Pontiac, MI 48340

Mailing Address Information:

Mail To: Chicago, Central & Pacific Railroad Company
Attn: Thomas L. Brasseur
700 Pershing Rd
Pontiac, MI 48340

Flagging Protection Rates:

Basic daily rate – = \$1,300.00 per day
Monday thru Friday regular business hours
Includes 8 standard rate hours and 2 OT hours to set flags

Overtime rate – = \$150.00 per hour
hours in excess of 8 hours or outside of regular business hours

Weekend or holiday rate - = \$1,500.00 per day
\$150.00 per hour with a 10 hour minimum

Email the completed first page above to: thomas.brasseur@cn.ca

Revised 04-04-2017



Non-Freight Customer Electronic Payment Instructions

Important message: The following electronic payment information is only applicable to Non-Freight Invoices issued by Canadian National Railway and its subsidiaries listed below.						
Invoicing Company	Customer's Country	Payment Currency	Electronic Payment Information			
			Financial Institution	Electronic Funds Transfers EFT, Direct Deposits, ACH (CN Preferred)	WIRE Payments (Significant costs for both you and CN)	Email Address to send Remittance Details
Illinois Central Wisconsin Central, Bessemer & Lake Erie, Cedar River, Chicago Central, CV Properties, Elgin, Joliet & Eastern, Grand Trunk Western, Great Lakes Fleet, Pittsburg & Conneault, Sault Ste. Marie Bridge Co., Wisconsin Chicago	United States	USD	HARRIS TRUST AND SAVINGS BANK 311 WEST MONROE, CHICAGO, IL	GRAND TRUNK WESTERN ACCOUNT 274-733-5 US ROUTING (ABA): 071 000 288		nfcashmanagement@cn.ca

*For additional information or clarification please email nfcashmanagement@cn.ca

CONTRACTOR ENDORSEMENT

GENERAL TERMS AND PROVISIONS

SECTION 1. DEFINITION OF CONTRACTOR.

For purposes of this agreement, all references in this agreement to Contractor shall include Contractor's contractors, subcontractors, officers, agents and employees, and others acting under its or their authority. For purposes of clarity, Contractor agrees that any CIC (defined below) hired by Contractor is a subcontractor of Contractor and therefore included in the defined term Contractor pursuant to the foregoing sentence.

SECTION 2. ALL EXPENSES TO BE BORNE BY CONTRACTOR; SUPERVISION.

A. Contractor shall bear any and all costs and expenses associated with any work performed by Contractor (including without limitation any CIC), or any costs or expenses incurred by Railroad relating to this agreement.

B. Contractor, at its own expense, shall adequately police and supervise all work to be performed by Contractor and shall ensure that such work is performed in a safe manner as set forth in SECTION 15. The responsibility of Contractor for safe conduct and adequate policing and supervision of Contractor's work shall not be lessened or otherwise affected by Railroad's approval of plans and specifications involving the work, or by Railroad's collaboration in performance of any work, or by the presence at the work site of a Railroad Representative, or by compliance by Contractor with any requests or recommendations made by Railroad Representative.

SECTION 3. TERM; TERMINATION.

A. These general terms and provisions shall remain in effect for the term as stated in the Contractor Endorsement. Contractor agrees to notify the Railroad Representative in writing when it has completed its work on Railroad's property.

B. This agreement may be terminated by either party on twenty four (24) hours written notice to the other party.

SECTION 4. INSURANCE.

A. Contractor will, upon request, provide Railroad with the (i) insurance binders, policies, certificates and endorsements set forth in **Exhibit A** of this agreement, and (ii) the insurance endorsements obtained by each subcontractor as required under SECTION 21 of this agreement.

B. Upon request, all insurance correspondence, binders, policies, certificates and endorsements shall be sent to:

Union Pacific Railroad Company
Attn: Public Projects Manager
1400 Douglas Street, STOP 1690
Omaha, NE 68179

SECTION 5. PRECONSTRUCTION MEETING.

If the work to be performed by the Contractor will involve the Railroad providing any flagging protection (or if a CIC is approved to provide flagging protection pursuant to the terms set forth herein) and/or there is separate work to be performed by the Railroad, the Contractor confirms that no work shall commence until the Railroad and Contractor

participate in a preconstruction meeting involving flagging procedures and coordination of work activities of the Contractor and the Railroad (and any CIC, as applicable.)

SECTION 6. DISMISSAL OF CONTRACTOR'S EMPLOYEE.

At the request of Railroad, Contractor shall remove from Railroad's property any employee of Contractor who fails to conform to the instructions of the Railroad Representative in connection with the work on Railroad's property, and any right of Contractor shall be suspended until such removal has occurred. Contractor shall indemnify Railroad against any claims arising from the removal of any such employee from Railroad's property.

SECTION 7. CROSSINGS; COMPLIANCE WITH MUTCD AND FRA GUIDELINES.

A. No additional vehicular crossings (including temporary haul roads) or pedestrian crossings over Railroad's trackage shall be installed or used by Contractor without the prior written permission of Railroad.

B. Any permanent or temporary changes, including temporary traffic control, to crossings must conform to the Manual of Uniform Traffic Control Devices (MUTCD) and any applicable Federal Railroad Administration rules, regulations and guidelines, and must be reviewed by the Railroad prior to any changes being implemented. In the event the Railroad is found to be out of compliance with federal safety regulations due to the Contractor's modifications, negligence, or any other reason arising from the Contractor's presence on the Railroad's property, the Contractor agrees to assume liability for any civil penalties imposed upon the Railroad for such noncompliance.

SECTION 8. EXPLOSIVES.

Explosives or other highly flammable substances shall not be stored or used on Railroad's property without the prior written approval of Railroad.

SECTION 9. NOTICE OF COMMENCEMENT OF WORK - RAILROAD FLAGGING - PRIVATE FLAGGING.

A. Contractor agrees to notify the Railroad Representative at least ten (10) working days in advance of Contractor commencing its work and at least thirty (30) working days in advance of proposed performance of any work by Contractor in which any person or equipment will be within twenty-five (25) feet of any track, or will be near enough to any track that any equipment extension (such as, but not limited to, a crane boom) will reach to within twenty-five (25) feet of any track.

B. No work of any kind shall be performed, and no person, equipment, machinery, tool(s), material(s), vehicle(s), or thing(s) shall be located, operated, placed, or stored within twenty-five (25) feet of any of Railroad's track(s) at any time, for any reason, unless and until a Railroad approved flagman is provided to watch for trains. Upon receipt of such thirty (30)-day notice, the Railroad Representative will determine and inform Contractor whether a flagman need be present and whether Contractor needs to implement any special protective or safety measures.

C. Contractor shall be permitted to hire a private contractor to perform flagging or other special protective or safety measures (such private contractor being commonly known in the railroad industry as a contractor-in-charge ("CIC")) in lieu of Railroad providing such services or in concert with Railroad providing such services, subject to prior written approval by Railroad, which approval shall be in Railroad's sole and absolute discretion. If Railroad agrees to permit Contractor to utilize a CIC pursuant to the preceding sentence, Contractor shall obtain Railroad's prior approval in writing for each of the following items, as determined in all respects in Railroad's sole and absolute discretion: (i) the identity of the third-party performing the role of CIC; (ii) the scope of the services to be performed for the project by the approved CIC; and (iii) any other terms and conditions governing such services to be provided by the CIC. If flagging or other special protective or safety measures are performed by an approved CIC, Contractor shall be solely responsible for (and shall timely pay such CIC for) its services. Railroad reserves the right to rescind any approval pursuant to this Subsection C., in whole or in part, at any time, as determined in Railroad's sole and absolute discretion.

D. If any flagging or other special protective or safety measures are performed by employees of Railroad and/or any contractor of Railroad, Railroad will bill Contractor for such expenses incurred by Railroad, unless Railroad and a federal, state or local governmental entity have agreed that Railroad is to bill such expenses to the federal, state or local

governmental entity. If Railroad will be sending the bills to Contractor, Contractor shall pay such bills within thirty (30) days of Contractor's receipt of billing.

E. If any flagging or other special protective or safety measures are performed by Railroad or a CIC, Contractor agrees that Contractor is not relieved of any of its responsibilities or liabilities set forth in this agreement.

F. The provisions set forth in this subsection are only applicable for Flagging Services performed by employees of Railroad: the rate of pay per hour for each flagman will be the prevailing hourly rate in effect for an eight-hour day for the class of flagmen used during regularly assigned hours and overtime in accordance with labor agreements and schedules in effect at the time the work is performed. In addition to the cost of such labor, a composite charge for vacation, holiday, health and welfare, supplemental sickness, Railroad Retirement and unemployment compensation, supplemental pension, Employees Liability and Property Damage and Administration will be included, computed on actual payroll. The composite charge will be the prevailing composite charge in effect at the time the work is performed. One and one-half times the current hourly rate is paid for overtime, Saturdays and Sundays, and two and one-half times current hourly rate for holidays. Wage rates are subject to change, at any time, by law or by agreement between Railroad and its employees, and may be retroactive as a result of negotiations or a ruling of an authorized governmental agency. Additional charges on labor are also subject to change. If the wage rate or additional charges are changed, Contractor (or the governmental entity, as applicable) shall pay on the basis of the new rates and charges. If flagging is performed by Railroad, reimbursement to Railroad will be required covering the full eight-hour day during which any flagman is furnished, unless the flagman can be assigned to other Railroad work during a portion of such day, in which event reimbursement will not be required for the portion of the day during which the flagman is engaged in other Railroad work. Reimbursement will also be required for any day not actually worked by the flagman following the flagman's assignment to work on the project for which Railroad is required to pay the flagman and which could not reasonably be avoided by Railroad by assignment of such flagman to other work, even though Contractor may not be working during such time. When it becomes necessary for Railroad to bulletin and assign an employee to a flagging position in compliance with union collective bargaining agreements, Contractor must provide Railroad a minimum of five (5) days notice prior to the cessation of the need for a flagman. If five (5) days notice of cessation is not given, Contractor will still be required to pay flagging charges for the five (5) day notice period required by union agreement to be given to the employee, even though flagging is not required for that period. An additional thirty (30) days notice must then be given to Railroad if flagging services are needed again after such five day cessation notice has been given to Railroad.

SECTION 10. LIMITATION AND SUBORDINATION OF RIGHTS GRANTED.

A. The foregoing grant of right is subject and subordinate to the prior and continuing right and obligation of the Railroad to use and maintain its entire property including the right and power of Railroad to construct, maintain, repair, renew, use, operate, change, modify or relocate railroad tracks, roadways, signal, communication, fiber optics, or other wirelines, pipelines and other facilities upon, along or across any or all parts of its property, all or any of which may be freely done at any time or times by Railroad without liability to Contractor or to any other party for compensation or damages.

B. The foregoing grant is also subject to all outstanding superior rights (whether recorded or unrecorded and including those in favor of licensees and lessees of Railroad's property, and others) and the right of Railroad to renew and extend the same, and is made without covenant of title or for quiet enjoyment.

SECTION 11. NO INTERFERENCE WITH OPERATIONS OF RAILROAD AND ITS TENANTS.

A. Contractor shall conduct its operations so as not to interfere with the continuous and uninterrupted use and operation of the railroad tracks and property of Railroad, including without limitation, the operations of Railroad's lessees, licensees or others, unless specifically authorized in advance by the Railroad Representative. Nothing shall be done or permitted to be done by Contractor at any time that would in any manner impair the safety of such operations. When not in use, Contractor's machinery and materials shall be kept at least fifty (50) feet from the centerline of Railroad's nearest track, and there shall be no vehicular crossings of Railroads tracks except at existing open public crossings.

B. Operations of Railroad and work performed by Railroad personnel and delays in the work to be performed by Contractor caused by such railroad operations and work are expected by Contractor, and Contractor agrees that Railroad shall have no liability to Contractor, or any other person or entity for any such delays. The Contractor shall

coordinate its activities with those of Railroad and third parties so as to avoid interference with railroad operations. The safe operation of Railroad train movements and other activities by Railroad takes precedence over any work to be performed by Contractor.

SECTION 12. LIENS.

Contractor shall pay in full all persons who perform labor or provide materials for the work to be performed by Contractor. Contractor shall not create, permit or suffer any mechanic's or materialmen's liens of any kind or nature to be created or enforced against any property of Railroad for any such work performed. Contractor shall indemnify and hold harmless Railroad from and against any and all liens, claims, demands, costs or expenses of whatsoever nature in any way connected with or growing out of such work done, labor performed, or materials furnished. If Contractor fails to promptly cause any lien to be released of record, Railroad may, at its election, discharge the lien or claim of lien at Contractor's expense.

SECTION 13. PROTECTION OF FIBER OPTIC CABLE SYSTEMS.

A. Fiber optic cable systems may be buried on Railroad's property. Protection of the fiber optic cable systems is of extreme importance since any break could disrupt service to users resulting in business interruption and loss of revenue and profits. Contractor shall telephone Railroad during normal business hours (7:00 a.m. to 9:00 p.m. Central Time, Monday through Friday, except holidays) at 1-800-336-9193 (also a 24-hour, 7-day number for emergency calls) to determine if fiber optic cable is buried anywhere on Railroad's property to be used by Contractor. If it is, Contractor will telephone the telecommunications company(ies) involved, make arrangements for a cable locator and, if applicable, for relocation or other protection of the fiber optic cable. Contractor shall not commence any work until all such protection or relocation (if applicable) has been accomplished.

B. IN ADDITION TO OTHER INDEMNITY PROVISIONS IN THIS AGREEMENT, CONTRACTOR SHALL INDEMNIFY, DEFEND AND HOLD RAILROAD HARMLESS FROM AND AGAINST ALL COSTS, LIABILITY AND EXPENSE WHATSOEVER (INCLUDING, WITHOUT LIMITATION, ATTORNEYS' FEES, COURT COSTS AND EXPENSES) ARISING OUT OF ANY ACT OR OMISSION OF CONTRACTOR, ITS AGENTS AND/OR EMPLOYEES, THAT CAUSES OR CONTRIBUTES TO (1) ANY DAMAGE TO OR DESTRUCTION OF ANY TELECOMMUNICATIONS SYSTEM ON RAILROAD'S PROPERTY, AND/OR (2) ANY INJURY TO OR DEATH OF ANY PERSON EMPLOYED BY OR ON BEHALF OF ANY TELECOMMUNICATIONS COMPANY, AND/OR ITS CONTRACTOR, AGENTS AND/OR EMPLOYEES, ON RAILROAD'S PROPERTY. CONTRACTOR SHALL NOT HAVE OR SEEK RECOURSE AGAINST RAILROAD FOR ANY CLAIM OR CAUSE OF ACTION FOR ALLEGED LOSS OF PROFITS OR REVENUE OR LOSS OF SERVICE OR OTHER CONSEQUENTIAL DAMAGE TO A TELECOMMUNICATION COMPANY USING RAILROAD'S PROPERTY OR A CUSTOMER OR USER OF SERVICES OF THE FIBER OPTIC CABLE ON RAILROAD'S PROPERTY.

SECTION 14. PERMITS - COMPLIANCE WITH LAWS.

In the prosecution of the work covered by this agreement, Contractor shall secure any and all necessary permits and shall comply with all applicable federal, state and local laws, regulations and enactments affecting the work including, without limitation, all applicable Federal Railroad Administration regulations.

SECTION 15. SAFETY.

A. Safety of personnel, property, rail operations and the public is of paramount importance in the prosecution of the work performed by Contractor. Contractor shall be responsible for initiating, maintaining and supervising all safety, operations and programs in connection with the work. Contractor shall at a minimum comply with Railroad's safety standards listed in **Exhibit B**, hereto attached, to ensure uniformity with the safety standards followed by Railroad's own forces. As a part of Contractor's safety responsibilities, Contractor shall notify Railroad if Contractor determines that any of Railroad's safety standards are contrary to good safety practices. Contractor shall furnish copies of **Exhibit B** to each of its employees before they enter the job site.

B. Without limitation of the provisions of paragraph A above, Contractor shall keep the job site free from safety and health hazards and ensure that its employees are competent and adequately trained in all safety and health aspects of the job.

C. Contractor shall have proper first aid supplies available on the job site so that prompt first aid services may be provided to any person injured on the job site. Contractor shall promptly notify Railroad of any U.S. Occupational Safety and Health Administration reportable injuries. Contractor shall have a nondelegable duty to control its employees while they are on the job site or any other property of Railroad, and to be certain they do not use, be under the influence of, or have in their possession any alcoholic beverage, drug or other substance that may inhibit the safe performance of any work.

D. If and when requested by Railroad, Contractor shall deliver to Railroad a copy of Contractor's safety plan for conducting the work (the "Safety Plan"). Railroad shall have the right, but not the obligation, to require Contractor to correct any deficiencies in the Safety Plan. The terms of this agreement shall control if there are any inconsistencies between this agreement and the Safety Plan.

SECTION 16. INDEMNITY.

A. TO THE EXTENT NOT PROHIBITED BY APPLICABLE STATUTE, CONTRACTOR SHALL INDEMNIFY, DEFEND AND HOLD HARMLESS RAILROAD, ITS AFFILIATES, AND ITS AND THEIR OFFICERS, AGENTS AND EMPLOYEES (INDIVIDUALLY AN "INDEMNIFIED PARTY" OR COLLECTIVELY "INDEMNIFIED PARTIES") FROM AND AGAINST ANY AND ALL LOSS, DAMAGE, INJURY, LIABILITY, CLAIM, DEMAND, COST OR EXPENSE (INCLUDING, WITHOUT LIMITATION, ATTORNEY'S, CONSULTANT'S AND EXPERT'S FEES, AND COURT COSTS), FINE OR PENALTY (COLLECTIVELY, "LOSS") INCURRED BY ANY PERSON (INCLUDING, WITHOUT LIMITATION, ANY INDEMNIFIED PARTY, CONTRACTOR, OR ANY EMPLOYEE OF CONTRACTOR OR OF ANY INDEMNIFIED PARTY) ARISING OUT OF OR IN ANY MANNER CONNECTED WITH (I) ANY WORK PERFORMED BY CONTRACTOR, OR (II) ANY ACT OR OMISSION OF CONTRACTOR, ITS OFFICERS, AGENTS OR EMPLOYEES, OR (III) ANY BREACH OF THIS AGREEMENT BY CONTRACTOR.

B. THE RIGHT TO INDEMNITY UNDER THIS SECTION SHALL ACCRUE UPON OCCURRENCE OF THE EVENT GIVING RISE TO THE LOSS, AND SHALL APPLY REGARDLESS OF ANY NEGLIGENCE OR STRICT LIABILITY OF ANY INDEMNIFIED PARTY, EXCEPT WHERE THE LOSS IS CAUSED BY THE SOLE ACTIVE NEGLIGENCE OF AN INDEMNIFIED PARTY AS ESTABLISHED BY THE FINAL JUDGMENT OF A COURT OF COMPETENT JURISDICTION. THE SOLE ACTIVE NEGLIGENCE OF ANY INDEMNIFIED PARTY SHALL NOT BAR THE RECOVERY OF ANY OTHER INDEMNIFIED PARTY.

C. CONTRACTOR EXPRESSLY AND SPECIFICALLY ASSUMES POTENTIAL LIABILITY UNDER THIS SECTION FOR CLAIMS OR ACTIONS BROUGHT BY CONTRACTOR'S OWN EMPLOYEES. CONTRACTOR WAIVES ANY IMMUNITY IT MAY HAVE UNDER WORKER'S COMPENSATION OR INDUSTRIAL INSURANCE ACTS TO INDEMNIFY THE INDEMNIFIED PARTIES UNDER THIS SECTION. CONTRACTOR ACKNOWLEDGES THAT THIS WAIVER WAS MUTUALLY NEGOTIATED BY THE PARTIES HERETO.

D. NO COURT OR JURY FINDINGS IN ANY EMPLOYEE'S SUIT PURSUANT TO ANY WORKER'S COMPENSATION ACT OR THE FEDERAL EMPLOYERS' LIABILITY ACT AGAINST A PARTY TO THIS AGREEMENT MAY BE RELIED UPON OR USED BY CONTRACTOR IN ANY ATTEMPT TO ASSERT LIABILITY AGAINST ANY INDEMNIFIED PARTY.

E. THE PROVISIONS OF THIS SECTION SHALL SURVIVE THE COMPLETION OF ANY WORK PERFORMED BY CONTRACTOR OR THE TERMINATION OR EXPIRATION OF THIS AGREEMENT. IN NO EVENT SHALL THIS SECTION OR ANY OTHER PROVISION OF THIS AGREEMENT BE DEEMED TO LIMIT ANY LIABILITY CONTRACTOR MAY HAVE TO ANY INDEMNIFIED PARTY BY STATUTE OR UNDER COMMON LAW.

SECTION 17. RESTORATION OF PROPERTY.

In the event Railroad authorizes Contractor to take down any fence of Railroad or in any manner move or disturb any of the other property of Railroad in connection with the work to be performed by Contractor, then in that event Contractor shall, as soon as possible and at Contractor's sole expense, restore such fence and other property to the same condition as the same were in before such fence was taken down or such other property was moved or disturbed. Contractor shall remove all of Contractor's tools, equipment, rubbish and other materials from Railroad's property promptly upon completion of the work, restoring Railroad's property to the same state and condition as when Contractor entered thereon.

SECTION 18. WAIVER OF DEFAULT.

Waiver by Railroad of any breach or default of any condition, covenant or agreement herein contained to be kept, observed and performed by Contractor shall in no way impair the right of Railroad to avail itself of any remedy for any subsequent breach or default.

SECTION 19. MODIFICATION - ENTIRE AGREEMENT.

No modification of this agreement shall be effective unless made in writing and signed by Contractor and Railroad. This agreement and the exhibits attached hereto and made a part hereof constitute the entire understanding between Contractor and Railroad and cancel and supersede any prior negotiations, understandings or agreements, whether written or oral, with respect to the work to be performed by Contractor.

SECTION 20. ASSIGNMENT.

Contractor shall not assign or subcontract this agreement, or any interest therein, without the written consent of the Railroad.

SECTION 21. SUBCONTRACTING.

Contractor shall be responsible for the acts and omissions of all subcontractors. Before Contractor commences any work, the Contractor shall, except to the extent prohibited by law; (1) require each of its subcontractors to include the Contractor as "Additional Insured" on the subcontractor's Commercial General Liability policy and Umbrella or Excess policies (if applicable) with respect to all liabilities arising out of the subcontractor's performance of work on behalf of the Contractor by endorsing these policies with ISO Additional Insured Endorsements CG 20 10, and CG 20 37 (or substitute forms providing equivalent coverage; (2) require each of its subcontractors to endorse their Commercial General Liability Policy with "Contractual Liability Railroads" ISO Form CG 24 17 10 01 (or a substitute form providing equivalent coverage) for the job site; and (3) require each of its subcontractors to endorse their Business Automobile Policy with "Coverage For Certain Operations In Connection With Railroads" ISO Form CA 20 70 10 01 (or a substitute form providing equivalent coverage) for the job site.

EXHIBIT A

TO GENERAL TERMS AND CONDITIONS OF THE CONTRACTOR'S ENDORSEMENT

INSURANCE PROVISIONS FOR CONTRACTOR ENDORSEMENT

Contractor shall, at its sole cost and expense, procure and maintain during the course of the project and until all project Work on Railroad's property has been completed and the Contractor has removed all equipment and materials from Railroad's property and has cleaned and restored Railroad's property to Railroad's satisfaction, the following insurance coverage:

- A. Commercial General Liability insurance.** Commercial general liability (CGL) with a limit of not less than \$5,000,000 each occurrence and an aggregate limit of not less than \$10,000,000. CGL insurance must be written on ISO occurrence form CG 00 01 12 04 (or a substitute form providing equivalent coverage).

The policy must also contain the following endorsement, which must be stated on the certificate of insurance:

- Contractual Liability Railroads ISO form CG 24 17 10 01 (or a substitute form providing equivalent coverage) showing "Union Pacific Railroad Company Property" as the Designated Job Site.
- Designated Construction Project(s) General Aggregate Limit ISO Form CG 25 03 03 97 (or a substitute form providing equivalent coverage) showing the project on the form schedule.

- B. Business Automobile Coverage insurance.** Business auto coverage written on ISO form CA 00 01 10 01 (or a substitute form providing equivalent liability coverage) with a combined single limit of not less \$5,000,000 for each accident and coverage must include liability arising out of any auto (including owned, hired and non-owned autos).

The policy must contain the following endorsements, which must be stated on the certificate of insurance:

- Coverage For Certain Operations In Connection With Railroads ISO form CA 20 70 10 01 (or a substitute form providing equivalent coverage) showing "Union Pacific Property" as the Designated Job Site.
- Motor Carrier Act Endorsement - Hazardous materials clean up (MCS-90) if required by law.

- C. Workers' Compensation and Employers' Liability insurance.** Coverage must include but not be limited to:
- Contractor's statutory liability under the workers' compensation laws of the state where the work is being performed.
 - Employers' Liability (Part B) with limits of at least \$500,000 each accident, \$500,000 disease policy limit \$500,000 each employee.

If Contractor is self-insured, upon request, evidence of state approval and excess workers compensation coverage must be provided. Coverage must include liability arising out of the U. S. Longshoremen's and Harbor Workers' Act, the Jones Act, and the Outer Continental Shelf Land Act, if applicable.

- D. Railroad Protective Liability insurance.** Contractor must maintain "Railroad Protective Liability" (RPL) insurance written on ISO occurrence form CG 00 35 12 04 (or a substitute form providing equivalent coverage) on behalf of Railroad as named insured, with a limit of not less than \$2,000,000 per occurrence and an aggregate of \$6,000,000. The definition of "JOB LOCATION" and "WORK" on the declaration page of the policy shall refer to this agreement and shall describe all WORK or OPERATIONS performed under this agreement. Contractor shall provide this agreement to Contractor's insurance agent(s) and/or broker(s) and Contractor shall instruct such agent(s) and/or broker(s) to procure the insurance coverage required by this agreement. UPON REQUEST, A BINDER STATING THE POLICY IS IN PLACE MUST BE SUBMITTED TO RAILROAD BEFORE THE WORK MAY COMMENCE AND UNTIL THE ORIGINAL POLICY IS FORWARDED TO UNION PACIFIC RAILROAD.

- E. **Umbrella or Excess** insurance. If Contractor utilizes umbrella or excess policies, these policies must "follow form" and afford no less coverage than the primary policy.
- F. **Pollution Liability** insurance. Pollution liability coverage must be included when the scope of the work as defined in the agreement includes installation, temporary storage, or disposal of any "hazardous" material that is injurious in or upon land, the atmosphere, or any watercourses; or may cause bodily injury at any time.

If required, coverage may be provided in separate policy form or by endorsement to Contractors CGL or RPL. Any form coverage must be equivalent to that provided in ISO form CG 24 15 "Limited Pollution Liability Extension Endorsement" or CG 28 31 "Pollution Exclusion Amendment" with limits of at least \$5,000,000 per occurrence and an aggregate limit of \$10,000,000.

If the scope of work as defined in this agreement includes the disposal of any hazardous or non-hazardous materials from the job site, upon request, Contractor must furnish to Railroad evidence of pollution legal liability insurance maintained by the disposal site operator for losses arising from the insured facility accepting the materials, with coverage in minimum amounts of \$1,000,000 per loss, and an annual aggregate of \$2,000,000.

Other Requirements

- G. All policy(ies) required above (except business automobile, worker's compensation and employers liability) must include Railroad as "Additional Insured" using ISO Additional Insured Endorsements CG 20 10, and CG 20 37 (or substitute forms providing equivalent coverage). The coverage provided to Railroad as additional insured shall not be limited by Contractor's liability under the indemnity provisions of this agreement. BOTH CONTRACTOR AND RAILROAD EXPECT THAT UNION PACIFIC RAILROAD COMPANY WILL BE PROVIDED WITH THE BROADEST POSSIBLE COVERAGE AVAILABLE BY OPERATION OF LAW UNDER ISO ADDITIONAL INSURED FORMS CG 20 10 AND CG 20 37.
- H. Punitive damages exclusion, if any, must be deleted (and the deletion indicated on the certificate of insurance), unless (a) insurance coverage may not lawfully be obtained for any punitive damages that may arise under this agreement, or (b) all punitive damages are prohibited by all states in which this agreement will be performed.
- I. Contractor waives all rights of recovery, and its insurers also waive all rights of subrogation of damages against Railroad and its agents, officers, directors and employees for damages covered by the workers compensation and employers liability or commercial umbrella or excess liability obtained by Contractor required in this agreement where prohibited by law. This waiver must be stated on the certificate of insurance.
- J. Upon request, Contractor shall furnish Railroad with a certificate(s) of insurance, executed by a duly authorized representative of each insurer, showing compliance with the insurance requirements in this agreement.
- K. All insurance policies must be written by a reputable insurance company acceptable to Railroad or with a current Best's Insurance Guide Rating of A- and Class VII or better, and authorized to do business in the state where the work is being performed.
- L. The fact that insurance is obtained by Contractor or by Railroad on behalf of Contractor will not be deemed to release or diminish the liability of Contractor, including, without limitation, liability under the indemnity provisions of this agreement. Damages recoverable by Railroad from Contractor or any third party will not be limited by the amount of the required insurance coverage.

EXHIBIT B

TO
GENERAL TERMS AND CONDITIONS
OF THE
CONTRACTOR'S ENDORSEMENT

MINIMUM SAFETY REQUIREMENTS

<https://www.up.com/suppliers/contractor-safety/index.htm>

TRAFFIC SIGNAL SPECIAL PROVISIONS



DUPAGE COUNTY TRAFFIC SIGNAL SPECIAL PROVISIONS

TRAFFIC SIGNAL GENERAL REQUIREMENTS

All work and equipment performed and installed under this Contract shall be governed by and shall comply with:

SPECIFICATION	ADOPTED/DATED
The State of Illinois "Standard Specifications for Road and Bridge Construction" referred to as "Standard Specifications"	April 1, 2016
The State of Illinois "Manual on Uniform Traffic Control Devices for Streets and Highways," referred to as "MUTCD"	June 2014
The National Electrical Code referred to as "NEC"	2011 Edition
The National Electrical Manufacturers Association (All publications for traffic control items) referred to as "NEMA"	All applicable current documents published prior to Contract Letting Date
The International Municipal Signal Association ("Official Wire & Cable Specifications Manual,") referred to as "IMSA"	All applicable current documents published prior to Contract Letting Date
The Institute of Transportation Engineers ATC 5.2b Standard	September 25, 2006
AASHTO "Standard Specifications" LRFD Specifications for Structural Supports for Highway Signs, Luminaires, and Traffic Signals	2015 Edition & 2017 Interim Revisions
Supplemental Specifications and Recurring Special Provisions	January 1, 2019

The project Special Provisions supplement the above specifications, manuals, and codes. In case of conflict with any part or parts of said documents, the project Special Provisions shall take precedence and shall govern.

The following terms and acronyms are used in the DUDOT traffic signal special provisions:

- | | |
|--|--|
| <ul style="list-style-type: none"> IDOT District 1 DUDOT Traffic Engineer Central Signal System Network Integration Consultant | <ul style="list-style-type: none"> Illinois Department of Transportation IDOT District 1 The DuPage County Division of Transportation The DUDOT Traffic Engineer or designee DuPage County's ITS System Currently Parsons Transportation Group |
|--|--|

The intent of these Special Provisions is to prescribe the materials and construction methods commonly used in traffic signal installations. The locations and the details of all installations shall be indicated on the plans or as directed by the Engineer.

All traffic signal work related to the traffic signal cabinet shall be performed with at least one electrician holding a current IMSA Traffic Signal Technician Level 2 certification present on site and actively overseeing and directing the work, unless approved in advance by the Traffic Engineer.

The work performed under this Contract shall consist of furnishing and installing all traffic signal work as shown on the plans and as specified herein in a manner acceptable and approved by the Resident Engineer. All materials furnished shall be new unless otherwise noted herein.

The phone number to contact DUDOT for all contract electrical questions or request is (630) 407-6900, which includes requests for detector location approval, transfer of maintenance, Traffic Signal Maintenance Contractor locates, equipment inspections, and traffic signal turn-ons.

Definitions of Terms.

Add the following to Section 101 of the Standard Specifications:

101.56 Vendor. Company that sells a particular type of product directly to the Contractor or the Equipment Supplier.

101.57 Equipment Supplier. Company that supplies, represents, and provides technical support for District 1 approved traffic signal controllers and other related equipment. The Equipment Supplier shall be located within District 1 and shall:

- a. Be full service with on-site facilities to assemble, test, and trouble-shoot traffic signal controllers and cabinet assemblies.
- b. Maintain an inventory of District 1 approved controllers and cabinets.
- c. Be staffed with permanent sales and technical personnel able to provide traffic signal controller and cabinet expertise and support.
- d. Technical staff shall attend traffic signal “turn-on” and inspection with a minimum 14 calendar day notice.

SUBMITTALS

Revise Article 801.05 of the Standard Specifications to read:

All material approval requests shall be submitted electronically unless otherwise directed by the Traffic Engineer. The submittal shall be by email, and shall include a cover letter and one PDF file with all pay items for the project.

General requirements include:

- a. All material approval requests shall be submitted within 7 calendar days after the preconstruction meeting. Traffic signal materials and equipment shall bear the U.L. label whenever such labeling is available.
- b. Original manufacturer published product data and shop drawing sheets with legible dimensions and details shall be submitted for review.

- c. Product data and shop drawings shall be arranged by pay item. Pages of the submittal should be numbered. If the literature contains more than one item, the Contractor shall indicate which item or items will be furnished.
- d. When hard copy submittals are necessary for another agency, four complete copies of the manufacturer's descriptive literatures and technical data for the traffic signal materials will be submitted, in addition to the electronic copy required above.
- e. When hard copy submittals are necessary for structural elements, four complete copies of the shop drawings for the mast arm assemblies and poles, and the combination mast arm assemblies and poles showing, in detail, the fabrication thereof and the certified mill analyses of the materials used in the fabrication, anchor rods, and reinforcing materials, shall be submitted, in addition to the electronic copy required above.
- f. Partial or incomplete submittals will be returned without review.
- g. Certain non-standard mast arm poles and structures will require additional review from IDOT's Bureau of Bridges and Structures. Examples include special mast arms and non-standard length mast arm pole assemblies. The Contractor shall account for the additional review time in their schedule.
- h. The County Section Number, permit number, or IDOT contract number, project location/limits and corresponding pay code number shall be on each sheet of correspondence, catalog cuts, and mast arm pole and assembly drawings.
- i. Where certifications and/or warranties are specified, the information submitted for approval shall include certifications and warranties. Certifications involving inspections, and/or tests of material shall include all test data, dates, and times.
- j. The Contractor shall secure approved materials in a timely manner to assure construction schedules are not delayed.
- k. After the Traffic Engineer reviews the submittals for conformance with the design concept of the project, the drawings will be stamped indicating their status as 'APPROVED', 'APPROVED AS CORRECTED', 'NOT APPROVED', or 'RESUBMIT'. Review schedule will be according to Article 801.05(b). Since the Traffic Engineer's review is for conformance with the design concept only, it is the Contractor's responsibility to coordinate the various items into a working system as specified. The Contractor shall not be relieved from responsibility for errors or omissions in the shop, working, layout drawings, or other documents by the Traffic Engineer's approval thereof.
- l. All submitted items reviewed and marked 'APPROVED AS CORRECTED', 'NOT APPROVED', or 'RESUBMIT' shall be resubmitted in their entirety, unless otherwise indicated within the submittal comments, with a disposition of previous comments to verify Contract compliance at no additional cost to the contract.
- m. It is the Contractor's responsibility to note any deviations from Contract requirements at the time of submittal and to make any requests for deviations in writing to the Resident Engineer. In general, substitutions will not be acceptable. Requests for substitutions shall demonstrate that the proposed substitution is superior to the material or equipment required by the Contract Documents. No

exceptions, deviations or substitutions will be permitted without the approval of the Resident Engineer and the Traffic Engineer.

- n. The Contractor shall not order major equipment (i.e., mast arm assemblies) prior to Resident Engineer approval of the Contractor marked proposed traffic signal equipment locations to assure proper placement of Contract required traffic signal displays, push buttons and other facilities. Field adjustments may require changes in proposed mast arm length and other coordination.

MARKING PROPOSED LOCATIONS

Revise “Marking Proposed Locations for Highway Lighting System” of Article 801.09 to read “Marking Proposed Locations for Highway Lighting System and Traffic Signals.”

Add the following to Article 801.09 of the Standard Specifications:

It shall be the Contractor's responsibility to verify all dimensions and conditions existing in the field prior to ordering materials and beginning construction. This shall include locating the mast arm foundations and verifying the mast arms lengths.

INSPECTION OF ELECTRICAL SYSTEMS

Add the following to Article 801.10 of the “Standard Specifications”:

- (c) All cabinets, including temporary traffic signal cabinets, shall be assembled by an approved Equipment Supplier in District 1. DUDOT reserves the right to request that any controller and cabinet be tested at a District 1 approved Equipment Supplier’s facility prior to field installation. Such testing will be at no extra cost to the contract. All permanent or temporary "railroad interconnected” controllers and cabinets, shall be new, built, tested and approved by the controller Equipment Supplier, in the Equipment Supplier’s District 1 approved facility, prior to field installation. The test shall be conducted in the presence of DUDOT and Illinois Commerce Commission personnel, or as directed by the Traffic Engineer. The Equipment Supplier shall provide the technical equipment and assistance as required by the Traffic Engineer to fully test this equipment.

LIQUIDATED DAMAGES FOR UNTIMELY WORK

A primary concern is to maintain a safe and efficient roadway for the public. Therefore, the Contractor shall proceed with the traffic signal work as soon as conditions and project staging permit. If in the opinion of the Traffic Engineer construction conditions are suitable for traffic signal work, and the Contractor has not yet begun the traffic signal work, the Resident Engineer shall notify the Contractor to proceed. The Contractor shall begin the traffic signal work within seven calendar days after notification to proceed. The Contractor shall continue to prosecute the traffic signal work until completion, or until they can no longer proceed due to conditions beyond their control. The Contractor shall notify the Resident Engineer of any conditions impeding and/or delaying their prosecution of the work. Failure by the Contractor to proceed with the traffic signal work as specified herein shall result in liquidated damages of **\$500.00** per calendar day per occurrence.

For projects involving detector loop installations or replacement, the following additional conditions apply. If, in the opinion, of the Traffic Engineer construction conditions are suitable for loop installation(s), the Resident Engineer shall notify the Contractor to proceed. The detector loops shall be installed and fully operational within 14 calendar days following notification to proceed by the Resident Engineer. This 14-day period shall be in effect throughout the entire year, including the off season, regardless of the Contractor's working day status. Failure by the Contractor to complete the loop installation(s) within the specified timeframe shall result in liquidated damages in the amount of \$500.00 per calendar day, per intersection.

For projects involving pavement resurfacing where radar, microwave, video, or other above-ground detection systems are included in the plans, the Contractor shall install the proposed detection system and make it operational prior to the grinding of the pavement loops, unless directed otherwise by the Engineer. In this case, the above-ground detection system will function as a temporary detector system, as well as the permanent system. The Contractor shall maintain the system according to these specifications, including adjusting detector orientation and detection zones, as necessary, to maintain proper detection throughout all stages of construction. Failure by the Contractor to install and operate the detector system within the specified timeframe shall result in liquidated damages in the amount of **\$500.00** per calendar day, per intersection.

MAINTENANCE AND RESPONSIBILITY

Revise Article 801.11 of the “Standard Specifications” to read:

- a. Existing traffic signal installations and/or any electrical facilities at locations included in this Contract may be altered or reconstructed totally or partially as part of the work on this contract. The Contractor is hereby advised that all traffic control equipment presently installed at these locations may be the property of the County of DuPage, State of Illinois, Department of Transportation, Division of Highways, County, Transit Agency, Private Developer, or a local governmental entity. Once the Contractor has begun any work on any portion of the project, all traffic signals within the limits of this Contract that have the pay item MAINTENANCE OF EXISTING TRAFFIC SIGNAL INSTALLATION, TEMPORARY TRAFFIC SIGNAL INSTALLATION, and/or MAINTENANCE OF EXISTING FLASHING BEACON INSTALLATION, shall become the full responsibility of the Contractor, unless otherwise approved in advance by the Traffic Engineer. The Contractor shall supply the Resident Engineer and the County’s Traffic Signal Maintenance Contractor one 24-hour emergency contact name and telephone number. The Contractor shall provide sufficient qualified personnel to respond to all notifications of malfunctions on a round-the-clock basis (24 hours a day, 7 days a week). The Contractor is required to keep a time and date log of all maintenance items, including the time of the initial report, the response time, and the time of final permanent repair. The Contractor shall provide this information to the Resident Engineer, upon request.
- b. When the project has a pay item for MAINTENANCE OF EXISTING TRAFFIC SIGNAL INSTALLATION, TEMPORARY TRAFFIC SIGNAL INSTALLATION, and/or MAINTENANCE OF EXISTING FLASHING BEACON INSTALLATION, the Contractor shall notify the Traffic Engineer at **(630) 407-6900** and the County’s Traffic Signal Maintenance Contractor of their intent to begin any physical construction work on the project. This notification shall be a minimum of ten calendar days prior to the start of construction to allow sufficient time for an inspection of the existing traffic signal installation(s) and the transfer of maintenance to the Contractor. If work is started prior to the inspection, maintenance of the traffic signal installation(s) will be immediately transferred to the Contractor without an inspection. The Contractor shall then become responsible for repairing or replacing all equipment that is not operating properly or is damaged at no cost to the owner of the traffic signal. Final repairs to or the replacement of damaged equipment shall meet the approval of the Traffic Engineer at the time of final inspection or the traffic signal installation will not be accepted.
- c. DUDOT, regional transit, IDOT, and other agencies may also have equipment connected to existing traffic signal or peripheral equipment including PTZ cameras, switches, transit signal priority (TSP and BRT) servers, modems, traffic counters, and other devices that shall be included with traffic signal maintenance at no additional cost to the contract.
- d. For contracts that include pay items for milling or pavement patching that may result in destruction of loop detectors, but do not include installation or modification of the traffic signals, maintenance

transfers are not required. These contracts do require a notification of intent to work and an inspection. A minimum of ten calendar days prior to the loop removal, the Contractor shall notify the Traffic Engineer at **(630) 407-6900**, at which time arrangements will be made to adjust the traffic controller timing to compensate for the absence of detection.

- e. The Contractor is advised that the existing and/or temporary traffic signal installation shall remain in operation during all construction stages, except for the most unavoidable down time. Any plan to shut down the traffic signal installation for a period exceeding 15 minutes shall require prior approval from the Traffic Engineer. Except in extraordinary circumstances, approval to shut down the traffic signal installation will only be granted during the hours of 9:00 A.M. to 3:00 P.M. on weekdays, exclusive of holiday periods. Requests for shutdowns outside of these hours, or during holiday periods, will not be granted unless the Traffic Engineer determines that the alternate schedule is beneficial to DuPage County highway operations. Shutdowns will not be allowed during inclement weather.
- f. The Contractor shall be fully responsible for the safe and efficient operation of the traffic signals. Any inquiry, complaint or request by DUDOT, the County's Traffic Signal Maintenance Contractor or the public, shall be investigated and repairs started. The Contractor shall restore service and complete permanent repairs according to the following Repair Timetable. Failure to provide this service will result in liquidated damages of **\$500** per calendar day per occurrence. The Traffic Engineer reserves the right to assign any work not completed within this timeframe to the County's Traffic Signal Maintenance Contractor. All costs associated with the completion of the uncompleted repair shall be the responsibility of the Contractor. Failure to pay these costs to the Traffic Signal Maintenance Contractor within one month after the incident will result in additional liquidated damages of **\$500** per month per occurrence. Unpaid bills will be deducted from the cost of the Contract. County personnel, the County's Traffic Signal Maintenance Contractor, and the County's Network Integration Consultant may inspect any signaling device on DUDOT's highway system at any time without notification.
- g. At signals where the Contractor is responsible for maintenance, including temporary traffic signals and newly constructed traffic signals that are operational but not yet accepted by the County, the Contractor shall be responsible for clearing snow, ice, dirt, debris or other condition that obstructs visibility of any traffic signal display or access to traffic signal equipment in compliance with the REPAIR TIMETABLE. Two clearly visible signal indications of all colors and arrows are required to be maintained at all time.
- h. In the event of power loss at locations where the Contractor is responsible for maintenance, including temporary traffic signals and newly constructed traffic signals that are not yet accepted by the County, the Contractor shall be responsible for working with DuPage County personnel to make connections of portable County-supplied generators at the maintained location, as directed by the Traffic Engineer or Resident Engineer.

All items shall be repaired within the period described in the Repair Timetable. The times listed are noncumulative. Any repairs not specifically covered in the Repair Timetable, or described elsewhere, shall be completed within a period matching the most similar line item in the Repair Timetable.

REPAIR TIMETABLE
(non cumulative)

<u>ITEM</u>	<u>RESPONSE TIME</u>	<u>SERVICE RESTORATION</u>	<u>PERMANENT REPAIRS</u>
<u>KNOCKDOWNS/FAILURE/DAMAGE:</u>			
Cabinet	1 hr	24 hrs	2 wks
Controller (Local or Master)	1 hr	24 hrs	2 wks
Detector Loop/Magnetometer	1 hr	n.a.	2 wks
Loop Detector Amplifier	1 hr	4 hrs	2 wks
Video Detection Camera/Processing Hardware	1 hr	4 hrs	2 wks
PTZ Camera	2 hrs	48 hrs	2 wks
Modem	2 hrs	NWD	2 wks
Load Switch/BIU	1 hr	2 hrs	2 hrs
Signal Head/Lenses	1 hr	2 hrs	NWD
Pole/Mast Arm	1 hr	2 hrs	ENG
Cabling/Conduit	1 hr	4 hrs	ENG
Interconnect/Communication	NWD	NWD	ENG
Graffiti/Advertising	NWD	NWD	NWD
Telemetry, Electrical	1 hr	2 hrs	NWD
Ethernet Switches/Video Encoders	NWD	48 hrs	2 wks
Indicators/switches/LEDs/displays	NWD	n.a.	2 wks
Snow/Ice/Debris/Other Obstructions	1 hr	2 hrs	NWD
Outages not covered elsewhere	1 hr	2 hrs	NWD
Filter/Cleanliness/fans/thermostat	NWD	NWD	n.a.
Misalignment (conflicting)	1 hr	2 hrs	NWD
Misalignment (non-conflicting)	4 hrs	6 hrs	NWD
<u>COMPLAINTS/CALLS/ALARMS:</u>			
Timing/Phasing/Programming	1 hr	2 hrs	ENG
Coordination Alarm/Cycle Fail	NWD	ENG	ENG
Controller Alarm/Status Change	1 hr	NWD	1 wk
Detector Alarm/Status change	NWD	NWD	ENG
UPS	1 hr	2 hrs	2 wks
CMU Flash/Local Flash	1 hr	2 hrs	1 wk
Door Open	1 hr	n.a.	NWD

LEGEND: hr=hour, hrs=hours, NWD=next week day, days=calendar days,
ENG=acceptable to Traffic Engineer, wk=week, wks=weeks, n.a.=not applicable

WORK NEAR HIGHWAY-RAIL GRADE CROSSINGS

Any proposed activity in the vicinity of a highway-rail grade crossing shall adhere to the guidelines set forth in the MUTCD regarding work in temporary traffic control zones in the vicinity of highway-rail grade crossings which states that lane restrictions, flagging, or other operations shall not create conditions where vehicles can be queued across the railroad tracks. If the queuing of vehicles across the tracks cannot be avoided, a uniformed law enforcement officer or flagger shall be provided at the crossing to prevent vehicles from stopping on the tracks, even if automatic warning devices are in place.

MODIFICATION OF IDOT SPECIAL PROVISION REQUIREMENTS

When IDOT Special Provisions for traffic signal items are included in a DUDOT Contract or Permit project, the following modifications shall apply to the noted Special Provisions.

Contact Information: The Contractor shall utilize the DUDOT contact information for DUDOT projects in place of the personnel, phone numbers, and directives provided in the following District 1 Special Provisions when they are included in the Contract:

- 800.02TS Optimize Signal System
- 800.03TS Re-Optimize Signal System
- 805.01TS Electric Service Installation
- 886.01TS Detector Loop
- 886.02TS Detector Loop Replacement and/or Installation
- 890.01TS Temporary Traffic Signal Installation
- 890.02TS Temporary Traffic Signal Timing

All references in the above special provisions to Traffic Signal Engineer, Area Traffic Signal Engineer, Area Traffic Signal Maintenance and Operations Engineer, Bureau of Traffic Operations, Traffic Operations Engineer, State, State's Traffic Signal Maintenance Contractor, and State's Electrical Maintenance Contractor shall be replaced with the DUDOT Traffic Engineer and the phone number shall be **630-407-6900**. Submittals, requests for reviews, scheduling of appointments, and requests for materials and information shall be directed to the DUDOT Traffic Engineer instead of IDOT, District 1, or the State's Maintenance Contractor.

Traffic Signal Timing Consultant Requirements: Add the following paragraph to the following District 1 Special Provisions:

- 800.02TS Optimize Signal System
- 800.03TS Re-Optimize Signal System
- 890.02TS Temporary Traffic Signal Timing

Graphics displays for DUDOT signal systems are not required if the signalized intersection is already connected to the county's Centracs software or if it is being added to Centracs under this contract.

Handhole Requirements: Add the following paragraph to the following District 1 Special Provision:

- 814.01 TS Handholes

The "Traffic Signals" label for the handhole lid shall also be applicable to DUDOT handholes.

DAMAGE TO TRAFFIC SIGNAL SYSTEM

Revise Article 801.12(b) of the "Standard Specifications" to read:

Any traffic control equipment damaged or not operating properly from any cause whatsoever shall be repaired and/or replaced. All inoperable components shall be replaced with new equipment meeting the special provisions, or in the absence of applicable special provisions, meeting the requirements of the Traffic Engineer. The Contractor shall provide replacement components at no additional cost to the Contract and/or owner of the traffic signal system. Final repairs or replacement of damaged equipment shall meet the approval of the Traffic Engineer prior to or at the time of final inspection; otherwise the traffic signal installation will not be accepted. Cable splices outside the controller cabinet shall not be allowed, unless approved by the Traffic Engineer.

When present, Automatic Traffic Enforcement equipment, including Red Light Enforcement cameras, detectors, and peripheral equipment, damaged or not operating properly from any cause whatsoever, shall be

the responsibility of the municipality or the Automatic Traffic Enforcement company according to the Permit or governing agreement.

VIDEO AND NETWORK SYSTEM REQUIREMENTS

For all projects including installation or relocation of video and/or network equipment, the Contractor shall contact the Traffic Engineer at 630-407-6900 after installation to confirm proper operation of the equipment within the Ethernet-based field communications system. This includes confirming that the camera horizon is properly adjusted, camera lens is clear, network settings are correct and all devices are communicating correctly with the Central Signal System. For equipment requiring an IP address or other DUDOT assigned parameters, the Traffic Engineer will provide all available IP and programming details upon request, but no earlier than at the pre-construction meeting. The Contractor should request the information from the Traffic Engineer a minimum of one week in advance of the traffic signal “turn-on.” The Contractor shall be responsible for making any changes necessary to the camera mounting, aiming, and/or equipment programming to meet the DUDOT requirements and/or to operate the equipment to the satisfaction of the Traffic Engineer. Contacting the Traffic Engineer for confirmation of equipment operation does not constitute an installation review and does not relieve the Contractor of the responsibility to correct deficiencies identified at the “turn-on.” The cost of meeting these requirements shall be included in the associated pay item and no additional compensation shall be made. Calls to the Traffic Engineer shall be made according to the Central Signal System Support section of this special provision.

TRAFFIC SIGNAL INSPECTION (“TURN-ON”)

Revise Article 801.15(b) of the “Standard Specifications” to read:

When the road is open to traffic, except as otherwise provided in Section 850 of the Standard Specifications, the Contractor may request a “turn-on” and inspection of the completed traffic signal installation at each separate location. This request shall be made to the Traffic Engineer at (630) 407-6900 a minimum of ten calendar days prior to the time of the requested inspection. Prior to the date of the “turn-on,” the Contractor must provide written notification (by letter or email) that the equipment has been field tested and the intersection is capable of operating according to Contract requirements.

When the Contract includes the pay item RE-OPTIMIZE TRAFFIC SIGNAL SYSTEM, OPTIMIZE TRAFFIC SIGNAL SYSTEM, or TEMPORARY TRAFFIC SIGNAL TIMINGS, the Contractor shall notify the Signal Coordination and Timing (SCAT) Consultant of the “turn-on”/detour implementation schedule, as well as stage changes and signal phase changes during construction. The SCAT Consultant shall be in attendance at each temporary and permanent traffic signal “turn-on.” When Emergency Vehicle Preemption (EVP) equipment is included in the project, the Contractor must invite local fire department personnel to each temporary and permanent traffic signal “turn-on.”

It is DUDOT’s intent to have all electric work completed and the equipment field-tested by the Equipment Supplier prior to DUDOT’s “turn-on” field inspection. The Contractor shall have all traffic signal work completed and the electrical service installation connected by the utility company prior to requesting an inspection and “turn-on” of the traffic signal installation. In the event the Traffic Engineer determines that the work is not complete and that the inspection will require more than two hours to complete, the inspection may be cancelled and the Contractor will be required to reschedule at another date.

The Contractor shall provide a representative from the Equipment Supplier’s office to attend the traffic signal inspection for both permanent and temporary traffic signal “turn-ons.” Signal indications being tested shall match the lane configurations and markings at the intersection. If any conflicting signal indications are visible to motorist or pedestrians while testing, the Contractor shall be responsible to provide police officer(s) to assist with traffic control at the time of testing.

Upon demonstration that the signals are operating properly according to the Contract and to the satisfaction of the Traffic Engineer, the Traffic Engineer will allow the signals to be placed in continuous operation. The Traffic Engineer will inspect the traffic signal installation, with the assistance of the Contractor, and provide a written "punch-list" of deficient items requiring completion. The traffic signals will not be transferred to DUDOT maintenance until all "punch-list" work is corrected and re-inspected. The Contractor shall complete all "punch-list" work within 30 calendar days of notification. If this work is not completed within 30 days, DUDOT reserves the right to have the work completed by others at the Contractor's expense. This cost will be in addition to Liquidated Damages for Untimely Work.

The Contractor shall furnish all equipment and/or parts to keep the traffic signal installation operating. No spare traffic signal equipment is available from DUDOT. The Contractor shall be responsible for all traffic signal equipment and associated maintenance thereof until DUDOT acceptance is granted.

When the Contractor has completed the "punch-list" work, he shall contact the Traffic Engineer to schedule a follow-up inspection of the traffic signal installation. If the Traffic Engineer determines that any "punch-list" items have not been completed, he may cancel the inspection, and the Contractor will need to reschedule.

It is possible that during any follow-up inspections of the traffic signal installation, deficient items may be identified that were not identified at the "turn-on" inspection, or included in the initial "punch-list." The Traffic Engineer shall advise the Contractor of any such items, and it shall be the Contractor's responsibility to complete these items prior to acceptance of the traffic signal.

Acceptance of the traffic signal by DUDOT shall be based on the inspection results and successful operation during a minimum 72-hour "burn-in" period following activation of the traffic signal and related equipment. Therefore, due to the required "burn-in" period, acceptance of the traffic signal shall not occur at the time of the "turn-on." Upon notification by the Contractor that all noted deficiencies have been corrected, and after the "burn-in" period, the Traffic Engineer shall perform an acceptance inspection of the traffic signal installation. If approved, the traffic signal acceptance shall be given verbally at the inspection, followed by written correspondence from the Traffic Engineer. When DUDOT is acting as a representative of other agencies, the agency that is responsible for the maintenance of each traffic signal installation will assume the traffic signal maintenance upon acceptance by the Traffic Engineer.

DUDOT requires the following Final Project Documentation from the Contractor prior to acceptance of the traffic signal. The documentation shall be provided in hard copy and electronic format as indicated below.

1. One (1) copy (11"x17") and one electronic PDF file of as-built signal plans with field revisions marked in red, including the location and labeling of detection equipment that differs from that shown in the plans.
2. One (1) copy of the operation and service manuals for the signal controller and the associated control equipment.
3. Five (5) copies (11"x17") and one electronic PDF file of the cabinet wiring diagrams.
4. Five (5) copies of the traffic signal installation cable log, along with electronic PDF and DGN files.
5. Original certificates for all manufacturer and Contractor warranties and guarantees required by Article 801.14 of the Standard Specifications.
6. GPS coordinates of traffic signal equipment as detailed in the Record Drawings section herein.
7. For new cabinet installations, two (2) cabinet keys and one (1) police door key.

All cost of work and materials required to comply with the above requirements shall be included in the pay item bid prices, under which the subject materials and signal equipment are paid, and no additional compensation will be allowed. Materials and signal equipment not complying with the above requirements will be subject to removal and disposal at the Contractor's expense.

LOCATING UNDERGROUND FACILITIES

Revise Section 803 of the "Standard Specifications" to read:

Once the Contractor has taken maintenance of an existing County facility or has constructed underground facilities, they are responsible for locating the facilities according the J.U.L.I.E. requirements at no additional cost to the Contract.

Contractor requests for equipment locates will be granted only once prior to the start of construction. Additional requests shall be at the expense of the Contractor. The location of underground traffic facilities does not relieve the Contractor of their responsibility to repair any item(s) damaged during the construction, at his/her own expense.

Locate requests shall be directed to DUDOT's Traffic Signal Maintenance Contractor or to the DUDOT Traffic Engineering Department at (630) 407-6900.

The exact location of all utilities shall be field verified by the Contractor before the installation of any components of the traffic signal system. For locations of utilities call J.U.L.I.E. at 1-800-892-0123. The location of some utilities may require contacting other Agencies or Municipalities.

The Contractor should note that IDOT does not participate in J.U.L.I.E. Underground work that is proposed to take place within IDOT right-of-way requires the Contractor to contact IDOT for the procedures involved in locating their facilities.

RESTORATION OF WORK AREA

Add to Section 801 of the "Standard Specifications":

Restoration of the traffic signal work area shall be included in the related pay item including foundation, conduit, handhole, trench and backfill, etc. and no extra compensation shall be allowed. All roadway surfaces including shoulders, medians, sidewalks, pavement, etc. shall be restored to match the previously existing conditions. All damage to mowed lawns shall be replaced with an approved sod, and all damage to unmowed fields shall be seeded, according to Section 250 and Section 252 of the Standard Specifications respectively. All brick pavers disturbed in the work area shall be restored to their original configuration as directed by the Resident Engineer. All damaged brick pavers shall be replaced with a comparable material approved by the Resident Engineer. Areas in front of residences are to be restored within two weeks of the completion of work causing the disturbance regardless of the duration of the project remaining. The traffic signal work area includes any area where the Contractor or their subcontractors perform work to install, repair, or maintain County owned traffic, lighting, or ITS equipment or facilities, regardless of the presence of an actual traffic signal.

LOCATION AND ORIENTATION OF ITS EQUIPMENT

The Contractor shall confirm the viability of the proposed mounting location for ITS equipment prior to installing cable, affixing mounting hardware to supporting posts or mast arms, and drilling holes in supporting posts or mast arms. When line-of-sight is required for proper equipment operations, including but not limited to antennas and detection cameras, the Contractor shall review the proposed installation with the Engineer, in consultation with the vendor's representative, to confirm that the location shown in the plans is still viable.

When a PTZ camera or other comparable device is proposed, the Contractor shall review the proposed location with the Engineer prior to installation to ensure that the Agency's preference for visibility can be met within the built environment. In any case, if the Contractor installs cable or hardware, or drills holes, prior to receiving the Engineer's approval, the cost to relocate the equipment to provide proper operation or preferred visibility, including the cost of removing and installing new electrical or communications cable, will be borne by the Contractor. The Contractor will be paid for the actual quantity of cable and equipment based on the final accepted installation location regardless of the quantities shown in the plan, and no additional compensation shall be made under the Contract for excess materials installed prior to approval.

CABINET NEATNESS AND WIRING

The Contractor shall ensure that all wiring and peripheral equipment in any new traffic signal cabinet is in a neat and orderly fashion that is acceptable to the Traffic Engineer. This applies to controller cabinets, master cabinets, railroad cabinets, communication/ITS cabinets, lighting cabinets, electrical service cabinets, or any other new cabinet called for in the project plans.

All conduit entrances into the cabinet shall be sealed with a pliable waterproof material. Electrical cables inside the cabinet shall be neatly trained along the base and back of the cabinet. Each conductor shall be connected individually to the proper terminal. The spare conductors shall be bound into a neat bundle. All cables, including those for signals, vehicle detection, pushbuttons, emergency vehicle preemption, video transmission, and communication shall be neatly arranged and bundled within the cabinet to the satisfaction of the Traffic Engineer. Each cable shall be marked with an identification number which corresponds to the number and description on the cabinet cable log.

When modernizing or modifying an existing cabinet, the new cables being installed shall be trained, bundled, and labeled to the satisfaction of the Traffic Engineer. When working inside an existing cabinet, the Contractor shall minimize disturbance to existing cables and cabinet wiring. Any existing cables and cabinet wiring disturbed by the Contractor shall be re-trained, bundled, and/or labeled to the satisfaction of the Traffic Engineer.

Unless indicated elsewhere in the plans and specs, all equipment in the cabinet shall be wired through the UPS except lighted street name signs and luminaires.

Components with Ethernet capabilities shall be connected to the Switch or other communications equipment in the cabinet as directed by the Traffic Engineer. All equipment, materials, labor and hardware, including Ethernet patch cables, required to provide cabinet neatness and wiring to the satisfaction of the Traffic Engineer shall be included in the applicable pay item for FULL ACTUATED CONTROLLER AND TYPE IV CABINET SPECIAL, FULL-ACTUATED CONTROLLER IN EXISTING CABINET, and/or MODIFY EXISTING CONTROLLER.

The County will not accept maintenance of the traffic signal installations until the above requirements are satisfied.

EQUIPMENT SUPPLIER AND VENDOR REPRESENTATION

The Traffic Engineer reserves the right to request a representative of the Equipment Supplier and/or Vendor be present at the activation of new traffic equipment. The traffic equipment may include signal heads, cabinets, controllers, amplifiers, preemption, detection, monitoring, communication/transmission, fiber-optic/telemetry, radio, microwave, infrared, illuminated signs, streetlights, push buttons, lighted crosswalks, uninterruptable power supplies, adaptive, counters, and any other new equipment being installed and activated. The representative shall be a qualified technician trained in the proper installation and operation of the equipment being installed under the Contract or permit.

The Traffic Engineer reserves the right to cancel the “turn-on,” transfer, or other scheduled activity if, in their opinion, knowledgeable personnel from the Equipment Supplier or Vendor are not present. Rescheduling, and any associated costs, shall be the responsibility of the Contractor, and shall be subject to availability of DUDOT Traffic staff.

This provision is in addition to the requirement contained herein that the Contractor provide a representative from the Equipment Supplier to attend the traffic signal inspection for both permanent and temporary traffic signal “turn-on”.

Any costs associated with Equipment Supplier and/or Vendor representation shall be included in the unit price of the associated traffic equipment being activated. Any unforeseen costs incurred by the Contractor to provide this representation shall not be the responsibility of the County.

INTERRUPTION OF COMMUNICATION

The interruption of communication with County equipment shall be kept to an absolute minimum. Communication includes controller telemetry, video transmission, camera control signals, Highway Advisory Radio, wireless interconnect, telephone (POTS/ISDN/DSL), high speed Internet, cellular modem, or any other County communication equipment. This provision applies to cable types including copper, multimode fiber optic, singlemode fiber optic, telephone cables, Ethernet cables, or any other cable used by the County to monitor and maintain its various signal and ITS equipment.

The Contractor shall plan ahead, and shall stage their construction work accordingly, so that they can interrupt communication, and then restore communication, with as little down time as possible. For example, when a section of existing interconnect is being relocated, the new handholes and conduits should be installed prior to disconnecting the interconnect cable. The interconnect cable can then be disconnected, pulled out of the existing conduit, pulled through the new conduit, and re-connected. In addition, when an existing fiber optic cable is to be re-used, the Contractor shall be prepared to immediately replace any fiber splices and/or terminations that become damaged.

Prior to disconnecting any DUDOT communication link, the Contractor shall contact the Traffic Engineer for approval of their planned construction method.

CENTRAL SIGNAL SYSTEM SUPPORT

DUDOT Traffic staff are available to provide a limited amount of technical support to the Contractor between the hours of 8:00 AM and 4:30 PM. The Contractor may request the DUDOT staff provide configuration information, settings, and testing support, and other items approved by the Traffic Engineer. Requests that require DUDOT support after 4:30 PM may not be honored until the next business day. Extensions to the Contract working days or completion date will not be authorized solely due to requests for support that do not meet these requirements.

CONSTRUCTION WORK UNDER COUNTY HIGHWAY PERMIT

For projects being completed under DuPage County Highway Access Permits, including resurfacing projects that require replacement of detector loops, the Contractor shall have a copy of the approved County Highway Permit on-site at all times work is underway, including when working on loops or other signal related equipment at county-owned intersections even if all work is located outside of DuPage County right-of-way. Penalties for non-compliance will be assessed according to the terms detailed in the Highway Permit.

DETECTOR LOOP REPLACEMENT

Description. This work consists of the complete replacement and testing of traffic signal detector loops damaged during pavement milling and patching operations, in accordance with the applicable portions of Sections, 810, 816, and 886 of the Standard Specifications, Details, and as specified herein.

Construction Requirements. The Contractor shall notify the maintaining agency seven days prior to beginning any operation which may damage existing detector loops at signalized intersections. If damage to the loops is unavoidable, replacement of the existing detection system will be necessary. The work shall be done by an IDOT pre-qualified Electrical Contractor as directed by the Engineer.

Replacement of the loops shall be completed prior to the final surfacing, and shall be accomplished in the following manner. The Contractor shall mark the location of the replacement loops. The County Traffic Signal Coordinator shall be called to approve loop locations prior to the cutting of the pavement. The Contractor may reuse the existing conduit (duct between the existing handhole and the pavement) if it has not been damaged. All burrs shall be removed from the edges of the existing conduit which may cause damage to the new detector loop during installation. If the existing conduit is damaged beyond repair, or if it cannot be located, or if additional conduits are required to provide one lead-in duct for each proposed loop, the Contractor will be required to drill through the existing pavement and into the appropriate handhole, and install 1 inch unit duct conduit. Upon establishment of the duct, the loop may be cut, installed, sealed and spliced to the twisted-shielded cable in the handhole.

The detector loops shall be in operation within 10 calendar days after the placement of level binder is completed.

Method of Measurement. This work will be measured for payment in feet along the sawed slot in the pavement containing the loop and lead-in, rather than the actual length of wire in the slot.

Basis of Payment. This work will be paid for at the contract unit price per FOOT of DETECTOR LOOP REPLACEMENT.

ELECTRICAL CABLE

Description. This work shall consist of furnishing and installing an electric cable of the type, size and number of conductors specified.

Materials. The electric cable shall meet the requirements of Article 1076.04 of the "Standard Specifications" and the following:

- Signal Cable: The conductors for signal cable shall be limited to No. 14 AWG solid copper.
- Service Cable: The service cable may be either single or multiple conductor cable.
- The electric service cable and grounding cable shall have an XLP jacket.
- All other cable jackets shall be polyvinyl chloride, meeting the requirements of IMSA 19-1 or IMSA 20-1.
- The jacket color for signal cable shall be black.
- The jacket color for lead-in and communications cable shall be gray.
- All cabling between the signal cabinet and the signal heads shall signal cable.
- Heat shrink splices shall be used according to the District 1 "Standard Traffic Signal Design Details" as shown on the plans.

General. This work shall be performed according to Section 873 of the “Standard Specifications”.

Method of Measurement. Electric Cable will be measured for payment in feet according to Article 873.05 of the “Standard Specifications”.

Basis of Payment. This work will be paid for at the contract unit price per foot for ELECTRIC CABLE, of the method of installation (IN TRENCH, IN CONDUIT, or AERIAL SUSPENDED), of the type, size and number of conductors or pairs specified.

MAINTENANCE OF EXISTING TRAFFIC SIGNAL INSTALLATION

Description. This work shall consist of maintaining an existing traffic signal installation that has been designated to remain in operation during construction.

General. This work will be performed according to Section 850 of the “Standard Specifications,” the DuPage County DOT Traffic Signal General Requirements DC800.01 Special Provision, and the following:

The Contractor shall provide the Engineer with a 24-hour telephone number for traffic signal maintenance, in accordance with the requirements of the DC800.01 Special Provision. The Contractor, or his representative, shall be available on a 24-hour basis to respond to emergency calls by the Engineer, Traffic Engineer or other parties.

The Contractor shall have electricians on staff with IMSA Level II certification to provide signal maintenance.

Full maintenance responsibility shall start as soon as the Contractor begins any physical work on the contract or any portion thereof.

This item shall include maintenance of all traffic signal equipment at the intersection, including cameras, emergency vehicle pre-emption equipment, traffic counters, detection equipment, traffic signal control equipment, terminal servers, media converters, transit signal priority equipment, flashing beacons, uninterruptable power supply (UPS) and batteries, handholes, lighted signs, radios, modems, master controllers, telephone service installations, communication equipment, communication cables, conduits to adjacent intersections, and other traffic signal equipment. The Contractor shall at all times maintain in stock a sufficient amount of materials and equipment to provide effective temporary and permanent repairs.

The Contractor shall check all controllers every month, which will include opening the cabinet door and visually inspecting all timing intervals, relays, detectors, and pre-emption equipment to ensure that they are functioning properly. This item includes all portions of the emergency vehicle pre-emption system. The Contractor shall not clear equipment log buffers. The Contractor shall not remove any existing documentation from the cabinet; it shall remain in the cabinet and remain property of the County or the agency that owns the cabinet.

The Contractor shall respond to all emergency calls from the County or others according to the Repair Timetable and provide immediate corrective action. When equipment has been damaged or becomes faulty beyond repair, the Contractor shall replace it with new and identical equipment. The cost of furnishing and installing the replaced equipment shall be borne by the Contractor at no additional charge to the County. The Contractor may initiate action to recover damages from a responsible third party. If at any time the Contractor fails to perform all work as specified herein to keep the traffic signal installation in proper operating condition or if the Engineer or Traffic Engineer cannot contact the Contractor's designated personnel, the Traffic Engineer shall have the County's Traffic Signal Maintenance Contractor perform the required maintenance

work. The County's Traffic Signal Maintenance Contractor shall bill the Contractor for the total cost of the work. The Contractor shall pay this bill within 30 days of the date of receipt of the invoice or the cost of such work will be deducted from the amount due the Contractor. At any time requested, the Contractor shall allow the County's Traffic Signal Maintenance Contractor to open the cabinet and review the operation of the existing traffic signal installation that has been transferred to the Contractor for maintenance.

The Contractor shall provide immediate corrective action when any part of the system fails to function properly. Two far side signal heads facing each approach shall be considered the minimum acceptable signal operation pending permanent repairs. When repairs at a signalized intersection require that the controller be disconnected, and power is available, the Contractor shall place the traffic signal installation on flashing operation. The signals shall flash **RED** for all directions unless a different indication has been specified by the Traffic Engineer. When the signal is flashing **RED** or when the power is out, the Contractor shall be required to place at least 1 STOP sign (R1-1-36) meeting MUTCD requirements at each approach of the intersection as a temporary means of regulating traffic according to the Repair Timetable in the project special provisions. At approaches where a yellow flashing indication is directed by the Traffic Engineer, STOP signs will not be required. The Contractor shall maintain a sufficient number of STOP signs for all the signals under the Contractor's maintenance and have enough spare STOP signs in stock at all times to replace those which may be damaged or stolen.

Traffic signal equipment which is lost or not returned to the County for any reason shall be replaced with new equipment meeting the requirements of the project special provisions. or in the absence of applicable special provisions, meeting the requirements of the Traffic Engineer.

The Contractor shall be responsible for maintaining the hardware and cables related to the County's Ethernet-based signal and ITS communications system, including any Layer II or Layer III switches, video encoders, power supplies, cables, and peripherals, located in the cabinet maintained under this pay item. Routine programming of Video encoders, Layer II and Layer III switches will be maintained by the County's Network Integrator under separate County contract, except as noted in the plans. The Contractor shall provide cabinet access to the Network Integrator as necessary to maintain communications on the County's Ethernet communications network. Any electrical work required to maintain the communications equipment shall be the responsibility of the Contractor.

The Contractor will not be required to pay the energy charges for the operation of the existing traffic signal installation.

The Traffic Engineer may require the Contractor to transfer maintenance of a signal back to the County's Traffic Signal Maintenance Contractor (or other electrical contractor) for a short time. This may become necessary due to other signal projects in the area, or if the County needs to perform work at the signal. Any costs incurred by the Contractor for maintenance transfer inspections of this type shall be included in cost of pay item MAINTENANCE OF EXISTING TRAFFIC SIGNAL INSTALLATION.

Temporary replacement of damaged or knockdown of a mast arm pole assembly shall require construction of a full or partial span wire signal installation or other method approved by the Traffic Engineer.

Maintenance will not include Automatic Traffic Enforcement equipment, e.g. red light enforcement cameras, detectors, or peripheral equipment. If present, this equipment is operated and maintained by the local municipality and should be de-activated while the traffic signal is on Contractor maintenance.

Basis of Payment. This work shall be paid for at the Contract unit price each for MAINTENANCE OF EXISTING TRAFFIC SIGNAL INSTALLATION. Each intersection will be paid for separately. If two

intersections are operated by one traffic signal controller, it shall be considered as one intersection for the purposes of this pay item.

MODIFY EXISTING CONTROLLER AND CABINET

Description. This work shall be in accordance with Section 895 of the Standard Specifications and shall include the modification of existing control cabinet for the existing traffic signal equipment to be operate the proposed signal equipment and, if shown in the plans, to make the cabinet compatible and functioning within the DuPage County Central Signal System.

Construction Requirements. Installation of all proposed equipment within the existing traffic signal cabinet indicated in the plans, including but not limited to traffic signal detection hardware and wiring, communication equipment, and UPS and power distribution equipment, shall be completed in a workmanlike manner. The Contractor shall move any existing equipment in conflict with the proposed work to another suitable location in the cabinet in a workmanlike manner, including training cables so they do not interfere with routine access to cabinet components. Any required relocation of equipment within the cabinet shall be included in the cost of MODIFY EXISTING CONTROLLER AND CABINET. All necessary materials, parts and labor required for modifying the controller cabinet to accommodate the proposed equipment to be installed in the existing cabinet at the intersection shall be considered included in the cost of the pay item.

Existing Controllers shall be reprogrammed as needed to configure detectors, alarms, and other hardware, and to place the existing controller in the County's IP scheme. Necessary connections and modifications of existing connections shall be made to establish proper controller and cabinet operations. When the controller is to be configured for Ethernet-based operations, this work includes implementing NTCIP addresses and settings, and furnishing and installing the necessary Ethernet patch cable.

Basis of Payment. This work will be paid for at the contract unit price EACH for MODIFY EXISTING CONTROLLER AND CABINET, which price shall be payment in full for furnishing all materials, parts and labor to modify the existing controller, cabinet, and associated equipment necessary for proper operation to the satisfaction of the Engineer.

REMOVE EXISITNG TRAFFIC SIGNAL EQUIPMENT

Add the following to Article 895.05(a) of the Standard Specifications:

The traffic signal equipment which is to be removed and is to become the property of the Contractor shall be disposed of outside the right-of-way at the Contractor's expense.

All equipment to be returned to the DuPage County Division of Transportation (DUDOT) shall be delivered by the Contractor to DUDOT. The Contractor shall contact the Traffic Engineer at 630-407-6900 to schedule an appointment to deliver the equipment. No equipment will be accepted without a prior appointment. All equipment shall be delivered within 30 days of removing it from the traffic signal installation. The Contractor shall provide one hard copy and one electronic file of a list of equipment that is to remain the property of DUDOT, including model and serial numbers, where applicable. The Contractor shall also provide a copy of the plan sheet or Contract documents showing the quantities and type of equipment. Controllers and peripheral equipment from the same location shall be boxed together (equipment from different locations may not be mixed) and all boxes and controller cabinets shall be clearly marked or labeled with the location from which they were removed. DUDOT reserves the right to reject equipment that is not returned according

to these requirements. The Contractor shall be responsible for the condition of the traffic signal equipment from the time Contractor takes maintenance of the signal installation until the acceptance of a receipt drawn by the Traffic Engineer indicating the items have been returned in good condition.

The Contractor shall safely store and arrange for pick up or delivery of all equipment to be returned to agencies other than DUDOT. The Contractor shall package the equipment and provide all necessary documentation as stated above.

Traffic signal equipment which is lost or not returned to DUDOT for any reason shall be replaced by the Contractor with new equipment meeting the requirements of these Specifications at no cost to the contract.

For all traffic signal posts or mast arms to remain, all vacated holes remaining in existing posts or mast arms shall be plugged with a kneadable, two-part epoxy putty. The putty shall cure in two hours or less and, when dried, the putty shall be sandable and paintable. It shall be capable of withstanding up to 500 degree Fahrenheit temperatures, with minimum tensile strength of 6000 psi and compressive strength of 18 psi. Products that include asbestos are prohibited.

The epoxy putty shall be applied to each vacated hole according to manufacturer's recommendations. The putty shall be shaped and smoothed, and excess putty shall be removed before it hardens. After the putty is fully hardened, it shall be sanded, cleaned, and painted to match the traffic signal post or mast arm.

CHECK SHEET FOR RECURRING SPECIAL PROVISIONS
CHECKSHEET FOR LOCAL ROADS AND STREETS SPECIAL PROVISIONS
BDE SPECIAL PROVISIONS

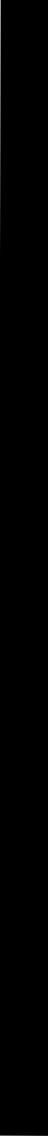

INDEX
FOR
SUPPLEMENTAL SPECIFICATIONS
AND RECURRING SPECIAL PROVISIONS

Adopted January 1, 2022

This index contains a listing of SUPPLEMENTAL SPECIFICATIONS, frequently used RECURRING SPECIAL PROVISIONS, and LOCAL ROADS AND STREETS RECURRING SPECIAL PROVISIONS.

No ERRATA this year.

SUPPLEMENTAL SPECIFICATIONS

Std. Spec. Sec.

Page No.

No Supplemental Specifications this year.



Local Public Agency	County	Section Number
DuPage County	DuPage	22-PVMTC-17-GM

Check this box for lettings prior to 01/01/2022.

The Following Recurring Special Provisions Indicated By An "X" Are Applicable To This Contract And Are Included By Reference:

Recurring Special Provisions

Check Sheet #		Reference Page No.
1	<input type="checkbox"/> Additional State Requirements for Federal-Aid Construction Contracts	1
2	<input type="checkbox"/> Subletting of Contracts (Federal-Aid Contracts)	4
3	<input type="checkbox"/> EEO	5
4	<input type="checkbox"/> Specific EEO Responsibilities Non Federal-Aid Contracts	15
5	<input type="checkbox"/> Required Provisions - State Contracts	20
6	<input type="checkbox"/> Asbestos Bearing Pad Removal	26
7	<input type="checkbox"/> Asbestos Waterproofing Membrane and Asbestos HMA Surface Removal	27
8	<input type="checkbox"/> Temporary Stream Crossings and In-Stream Work Pads	28
9	<input type="checkbox"/> Construction Layout Stakes	29
10	<input type="checkbox"/> Use of Geotextile Fabric for Railroad Crossing	32
11	<input type="checkbox"/> Subsealing of Concrete Pavements	34
12	<input type="checkbox"/> Hot-Mix Asphalt Surface Correction	38
13	<input type="checkbox"/> Pavement and Shoulder Resurfacing	40
14	<input type="checkbox"/> Patching with Hot-Mix Asphalt Overlay Removal	41
15	<input type="checkbox"/> Polymer Concrete	43
16	<input type="checkbox"/> PVC Pipeliner	45
17	<input type="checkbox"/> Bicycle Racks	46
18	<input type="checkbox"/> Temporary Portable Bridge Traffic Signals	48
19	<input type="checkbox"/> Nighttime Inspection of Roadway Lighting	50
20	<input type="checkbox"/> English Substitution of Metric Bolts	51
21	<input type="checkbox"/> Calcium Chloride Accelerator for Portland Cement Concrete	52
22	<input type="checkbox"/> Quality Control of Concrete Mixtures at the Plant	53
23	<input checked="" type="checkbox"/> Quality Control/Quality Assurance of Concrete Mixtures	61
24	<input type="checkbox"/> Digital Terrain Modeling for Earthwork Calculations	77
25	<input type="checkbox"/> Preventive Maintenance - Bituminous Surface Treatment (A-1)	79
26	<input type="checkbox"/> Temporary Raised Pavement Markers	85
27	<input type="checkbox"/> Restoring Bridge Approach Pavements Using High-Density Foam	86
28	<input type="checkbox"/> Portland Cement Concrete Inlay or Overlay	89
29	<input type="checkbox"/> Portland Cement Concrete Partial Depth Hot-Mix Asphalt Patching	93
30	<input type="checkbox"/> Longitudinal Joint and Crack Patching	96
31	<input type="checkbox"/> Concrete Mix Design - Department Provided	98
32	<input type="checkbox"/> Station Numbers in Pavements or Overlays	99

Local Public Agency

County

Section Number

DuPage County

DuPage

22-PVMTC-17-GM

The Following Local Roads And Streets Recurring Special Provisions Indicated By An "X" Are Applicable To This Contract And Are Included By Reference:

Local Roads And Streets Recurring Special Provisions

<u>Check Sheet #</u>		<u>Page No.</u>
LRS 1	Reserved	101
LRS 2	<input type="checkbox"/> Furnished Excavation	102
LRS 3	<input checked="" type="checkbox"/> Work Zone Traffic Control Surveillance	103
LRS 4	<input checked="" type="checkbox"/> Flaggers in Work Zones	104
LRS 5	<input checked="" type="checkbox"/> Contract Claims	105
LRS 6	<input checked="" type="checkbox"/> Bidding Requirements and Conditions for Contract Proposals	106
LRS 7	<input type="checkbox"/> Bidding Requirements and Conditions for Material Proposals	112
LRS 8	Reserved	118
LRS 9	<input type="checkbox"/> Bituminous Surface Treatments	119
LRS 10	Reserved	123
LRS 11	<input checked="" type="checkbox"/> Employment Practices	124
LRS 12	<input checked="" type="checkbox"/> Wages of Employees on Public Works	126
LRS 13	<input checked="" type="checkbox"/> Selection of Labor	128
LRS 14	<input type="checkbox"/> Paving Brick and Concrete Paver Pavements and Sidewalks	129
LRS 15	<input checked="" type="checkbox"/> Partial Payments	132
LRS 16	<input checked="" type="checkbox"/> Protests on Local Lettings	133
LRS 17	<input checked="" type="checkbox"/> Substance Abuse Prevention Program	134
LRS 18	<input type="checkbox"/> Multigrade Cold Mix Asphalt	135
LRS 19	<input type="checkbox"/> Reflective Crack Control Treatment	136

DuPage County Prevailing Wage Rates posted on 3/7/2022

Trade Title	Rg	Type	C	Base	Foreman	Overtime				H/W	Pension	Vac	Trng	Other Ins
						M-F	Sa	Su	Hol					
ASBESTOS ABT-GEN	All	ALL		45.90	46.90	1.5	1.5	2.0	2.0	16.55	14.71	0.00	0.90	
ASBESTOS ABT-MEC	All	BLD		38.85	41.96	1.5	1.5	2.0	2.0	14.42	12.61	0.00	0.82	
BOILERMAKER	All	BLD		52.61	57.34	2.0	2.0	2.0	2.0	6.97	22.34	0.00	1.40	
BRICK MASON	All	BLD		48.56	53.42	1.5	1.5	2.0	2.0	11.70	21.06	0.00	1.03	
CARPENTER	All	ALL		50.86	52.86	1.5	1.5	2.0	2.0	11.79	24.76	0.00	0.79	
CEMENT MASON	All	ALL		47.50	49.50	2.0	1.5	2.0	2.0	16.75	20.74	0.00	1.00	
CERAMIC TILE FINISHER	All	BLD		42.80	42.80	1.5	1.5	2.0	2.0	11.45	14.27	0.00	0.94	
COMMUNICATION TECHNICIAN	All	BLD		34.71	37.51	1.5	1.5	2.0	2.0	12.85	23.75	3.20	0.68	0.10
ELECTRIC PWR EQMT OP	All	ALL		46.06	62.84	1.5	1.5	2.0	2.0	6.75	12.90	0.00	1.15	1.38
ELECTRIC PWR GRNDMAN	All	ALL		35.38	62.84	1.5	1.5	2.0	2.0	6.75	9.91	0.00	0.88	1.06
ELECTRIC PWR LINEMAN	All	ALL		55.37	62.84	1.5	1.5	2.0	2.0	6.75	15.50	0.00	1.38	1.66
ELECTRIC PWR TRK DRV	All	ALL		36.67	62.84	1.5	1.5	2.0	2.0	6.75	10.27	0.00	0.92	1.10
ELECTRICIAN	All	BLD		41.83	46.08	1.5	1.5	2.0	2.0	12.85	27.00	6.85	0.95	0.10
ELEVATOR CONSTRUCTOR	All	BLD		60.42	67.97	2.0	2.0	2.0	2.0	15.87	19.31	4.83	0.64	
FENCE ERECTOR	NE	ALL		45.67	47.67	1.5	1.5	2.0	2.0	13.68	16.39	0.00	0.65	
FENCE ERECTOR	W	ALL		48.83	52.74	2.0	2.0	2.0	2.0	13.31	25.25	0.00	1.28	
GLAZIER	All	BLD		47.60	49.10	1.5	2.0	2.0	2.0	14.99	23.55	0.00	1.43	
HEAT/FROST INSULATOR	All	BLD		51.80	54.91	1.5	1.5	2.0	2.0	14.42	15.36	0.00	0.82	
IRON WORKER	E	ALL		54.51	56.51	2.0	2.0	2.0	2.0	15.40	25.06	0.00	0.44	
IRON WORKER	W	ALL		48.83	52.74	2.0	2.0	2.0	2.0	13.31	25.25	0.00	1.28	
LABORER	All	ALL		45.90	46.65	1.5	1.5	2.0	2.0	16.55	14.71	0.00	0.90	
LATHER	All	ALL		50.86	52.86	1.5	1.5	2.0	2.0	11.79	24.76	0.00	0.79	
MACHINIST	All	BLD		50.68	53.18	1.5	1.5	2.0	2.0	8.93	8.95	1.85	1.47	
MARBLE FINISHER	All	ALL		37.00	50.10	1.5	1.5	2.0	2.0	11.70	19.10	0.00	0.93	
MARBLE MASON	All	BLD		47.71	52.48	1.5	1.5	2.0	2.0	11.70	20.53	0.00	1.02	
MATERIAL TESTER I	All	ALL		35.90		1.5	1.5	2.0	2.0	16.55	14.71	0.00	0.90	
MATERIALS TESTER II	All	ALL		40.90		1.5	1.5	2.0	2.0	16.55	14.71	0.00	0.90	
MILLWRIGHT	All	ALL		50.86	52.86	1.5	1.5	2.0	2.0	11.79	24.76	0.00	0.79	
OPERATING ENGINEER	All	BLD	1	53.60	57.60	2.0	2.0	2.0	2.0	21.40	18.60	2.00	2.40	
OPERATING ENGINEER	All	BLD	2	52.30	57.60	2.0	2.0	2.0	2.0	21.40	18.60	2.00	2.40	
OPERATING ENGINEER	All	BLD	3	49.75	57.60	2.0	2.0	2.0	2.0	21.40	18.60	2.00	2.40	

OPERATING ENGINEER	All	BLD	4	48.00	57.60	2.0	2.0	2.0	2.0	21.40	18.60	2.00	2.40	
OPERATING ENGINEER	All	BLD	5	57.35	57.60	2.0	2.0	2.0	2.0	21.40	18.60	2.00	2.40	
OPERATING ENGINEER	All	BLD	6	54.60	57.60	2.0	2.0	2.0	2.0	21.40	18.60	2.00	2.40	
OPERATING ENGINEER	All	BLD	7	56.60	57.60	2.0	2.0	2.0	2.0	21.40	18.60	2.00	2.40	
OPERATING ENGINEER	All	FLT		41.00	41.00	1.5	1.5	2.0	2.0	20.90	17.85	2.00	2.15	
OPERATING ENGINEER	All	HWY	1	51.80	55.80	1.5	1.5	2.0	2.0	21.40	18.60	2.00	2.40	
OPERATING ENGINEER	All	HWY	2	51.25	55.80	1.5	1.5	2.0	2.0	21.40	18.60	2.00	2.40	
OPERATING ENGINEER	All	HWY	3	49.20	55.80	1.5	1.5	2.0	2.0	21.40	18.60	2.00	2.40	
OPERATING ENGINEER	All	HWY	4	47.80	55.80	1.5	1.5	2.0	2.0	21.40	18.60	2.00	2.40	
OPERATING ENGINEER	All	HWY	5	46.60	55.80	1.5	1.5	2.0	2.0	21.40	18.60	2.00	2.40	
OPERATING ENGINEER	All	HWY	6	54.80	55.80	1.5	1.5	2.0	2.0	21.40	18.60	2.00	2.40	
OPERATING ENGINEER	All	HWY	7	52.80	55.80	1.5	1.5	2.0	2.0	21.40	18.60	2.00	2.40	
ORNAMENTAL IRON WORKER	E	ALL		52.13	54.63	2.0	2.0	2.0	2.0	14.23	23.99	0.00	1.25	
ORNAMENTAL IRON WORKER	W	ALL		48.83	52.74	2.0	2.0	2.0	2.0	13.31	25.25	0.00	1.28	
PAINTER	All	ALL		49.30	51.30	1.5	1.5	1.5	2.0	19.08	4.15	0.00	1.10	
PAINTER - SIGNS	All	BLD		40.74	45.75	1.5	1.5	2.0	2.0	3.04	3.90	0.00	0.00	
PILEDRIVER	All	ALL		50.86	52.86	1.5	1.5	2.0	2.0	11.79	24.76	0.00	0.79	
PIPEFITTER	All	BLD		52.00	55.00	1.5	1.5	2.0	2.0	11.60	21.85	0.00	2.92	
PLASTERER	All	BLD		48.60	51.52	1.5	1.5	2.0	2.0	11.70	20.98	0.00	1.02	
PLUMBER	All	BLD		52.80	55.95	1.5	1.5	2.0	2.0	16.45	16.75	0.00	1.47	
ROOFER	All	BLD		46.70	50.70	1.5	1.5	2.0	2.0	11.58	14.56	0.00	0.96	
SHEETMETAL WORKER	All	BLD		51.83	54.42	1.5	1.5	2.0	2.0	11.22	19.08	0.00	1.45	2.46
SPRINKLER FITTER	All	BLD		52.25	55.00	1.5	1.5	2.0	2.0	14.20	18.60	0.00	0.75	
STEEL ERECTOR	E	ALL		54.51	56.51	2.0	2.0	2.0	2.0	15.40	25.06	0.00	0.44	
STEEL ERECTOR	W	ALL		48.83	52.74	2.0	2.0	2.0	2.0	13.31	25.25	0.00	1.28	
STONE MASON	All	BLD		48.56	53.42	1.5	1.5	2.0	2.0	11.70	21.06	0.00	1.03	
TERRAZZO FINISHER	All	BLD		44.54	44.54	1.5	1.5	2.0	2.0	11.45	16.64	0.00	0.97	
TERRAZZO MASON	All	BLD		48.38	51.88	1.5	1.5	2.0	2.0	11.45	18.10	0.00	1.00	
TILE MASON	All	BLD		49.75	53.75	1.5	1.5	2.0	2.0	11.45	17.98	0.00	1.02	
TRAFFIC SAFETY WORKER	All	HWY		38.50	40.10	1.5	1.5	2.0	2.0	8.90	8.90	0.00	0.90	
TRUCK DRIVER	All	ALL	1	40.06	40.61	1.5	1.5	2.0	2.0	10.15	13.57	0.00	0.15	
TRUCK DRIVER	All	ALL	2	40.21	40.61	1.5	1.5	2.0	2.0	10.15	13.57	0.00	0.15	
TRUCK DRIVER	All	ALL	3	40.41	40.61	1.5	1.5	2.0	2.0	10.15	13.57	0.00	0.15	
TRUCK DRIVER	All	ALL	4	40.61	40.61	1.5	1.5	2.0	2.0	10.15	13.57	0.00	0.15	
TUCKPOINTER	All	BLD		48.25	49.25	1.5	1.5	2.0	2.0	8.79	20.47	0.00	1.01	

Legend

Rg Region

Type Trade Type - All,Highway,Building,Floating,Oil & Chip,Rivers

C Class

Base Base Wage Rate

OT M-F Unless otherwise noted, OT pay is required for any hour greater than 8 worked each day, Mon through Fri. The number listed is the multiple of the base wage.

OT Sa Overtime pay required for every hour worked on Saturdays

OT Su Overtime pay required for every hour worked on Sundays

OT Hol Overtime pay required for every hour worked on Holidays

H/W Health/Welfare benefit

Vac Vacation

Trng Training

Other Ins Employer hourly cost for any other type(s) of insurance provided for benefit of worker.

Explanations DUPAGE COUNTY

IRON WORKERS AND FENCE ERECTOR (WEST) - West of Route 53.

The following list is considered as those days for which holiday rates of wages for work performed apply: New Years Day, Memorial Day, Fourth of July, Labor Day, Thanksgiving Day, Christmas Day and Veterans Day in some classifications/counties. Generally, any of these holidays which fall on a Sunday is celebrated on the following Monday. This then makes work performed on that Monday payable at the appropriate overtime rate for holiday pay. Common practice in a given local may alter certain days of celebration. If in doubt, please check with IDOL.

EXPLANATION OF CLASSES

ASBESTOS - GENERAL - removal of asbestos material/mold and hazardous materials from any place in a building, including mechanical systems where those mechanical systems are to be removed. This includes the removal of asbestos materials/mold and hazardous materials from ductwork or pipes in a building when the building is to be demolished at the time or at some close future date.

ASBESTOS - MECHANICAL - removal of asbestos material from mechanical systems, such as pipes, ducts, and boilers, where the mechanical systems are to remain.

TRAFFIC SAFETY

Effective November 30, 2018, the description of the traffic safety worker trade in this County is as follows: Work associated with barricades, horses and drums used to reduce lane usage on highway work, the installation and removal of temporary, non-temporary or permanent lane, pavement or roadway markings, and the installation and removal of temporary road signs.

CERAMIC TILE FINISHER

The grouting, cleaning, and polishing of all classes of tile, whether for interior or exterior purposes, all burned, glazed or unglazed products; all composition materials, granite tiles, warning detectable tiles, cement tiles, epoxy composite materials, pavers, glass, mosaics, fiberglass, and all substitute materials, for tile made in tile-like units; all mixtures in tile like form of cement, metals, and other materials that are for and intended for use as a finished floor surface, stair treads, promenade roofs, walks, walls, ceilings, swimming pools, and all other places where tile is to form a finished interior or exterior. The mixing of all setting mortars including but not limited to thin-set mortars, epoxies, wall mud, and any other sand and cement mixtures or adhesives when

used in the preparation, installation, repair, or maintenance of tile and/or similar materials. The handling and unloading of all sand, cement, lime, tile, fixtures, equipment, adhesives, or any other materials to be used in the preparation, installation, repair, or maintenance of tile and/or similar materials. Ceramic Tile Finishers shall fill all joints and voids regardless of method on all tile work, particularly and especially after installation of said tile work. Application of any and all protective coverings to all types of tile installations including, but not be limited to, all soap compounds, paper products, tapes, and all polyethylene coverings, plywood, masonite, cardboard, and any new type of products that may be used to protect tile installations, Blastrac equipment, and all floor scarifying equipment used in preparing floors to receive tile. The clean up and removal of all waste and materials. All demolition of existing tile floors and walls to be re-tiled.

COMMUNICATIONS TECHNICIAN

Low voltage installation, maintenance and removal of telecommunication facilities (voice, sound, data and video) including telephone and data inside wire, interconnect, terminal equipment, central offices, PABX, fiber optic cable and equipment, micro waves, V-SAT, bypass, CATV, WAN (wide area networks), LAN (local area networks), and ISDN (integrated system digital network), pulling of wire in raceways, but not the installation of raceways.

MARBLE FINISHER

Loading and unloading trucks, distribution of all materials (all stone, sand, etc.), stocking of floors with material, performing all rigging for heavy work, the handling of all material that may be needed for the installation of such materials, building of scaffolding, polishing if needed, patching, waxing of material if damaged, pointing up, caulking, grouting and cleaning of marble, holding water on diamond or Carborundum blade or saw for setters cutting, use of tub saw or any other saw needed for preparation of material, drilling of holes for wires that anchor material set by setters, mixing up of molding plaster for installation of material, mixing up thin set for the installation of material, mixing up of sand to cement for the installation of material and such other work as may be required in helping a Marble Setter in the handling of all material in the erection or installation of interior marble, slate, travertine, art marble, serpentine, alberene stone, blue stone, granite and other stones (meaning as to stone any foreign or domestic materials as are specified and used in building interiors and exteriors and customarily known as stone in the trade), carrara, sanionyx, vitrolite and similar opaque glass and the laying of all marble tile, terrazzo tile, slate tile and precast tile, steps, risers treads, base, or any other materials that may be used as substitutes for any of the aforementioned materials and which are used on interior and exterior which are installed in a similar manner.

MATERIAL TESTER I: Hand coring and drilling for testing of materials; field inspection of uncured concrete and asphalt.

MATERIAL TESTER II: Field inspection of welds, structural steel, fireproofing, masonry, soil, facade, reinforcing steel, formwork, cured concrete, and concrete and asphalt batch plants; adjusting proportions of bituminous mixtures.

OPERATING ENGINEER - BUILDING

Class 1. Asphalt Plant; Asphalt Spreader; Autograde; Backhoes with Caisson Attachment; Batch Plant; Benoto (requires Two Engineers); Boiler and Throttle Valve; Caisson Rigs; Central Redi-Mix Plant; Combination Back Hoe Front End-loader Machine; Compressor and Throttle Valve; Concrete Breaker (Truck Mounted); Concrete Conveyor; Concrete Conveyor (Truck Mounted); Concrete Paver Over 27E cu. ft; Concrete Paver 27E cu. ft. and Under; Concrete Placer; Concrete Placing Boom; Concrete Pump (Truck Mounted); Concrete Tower; Cranes, All; Cranes, Hammerhead; Cranes, (GCI and similar Type); Creter Crane; Spider Crane; Crusher, Stone, etc.; Derricks, All; Derricks, Traveling; Formless Curb and Gutter Machine; Grader, Elevating; Grouting Machines; Heavy Duty Self-Propelled Transporter or Prime Mover; Highlift Shovels or Front Endloader 2-1/4 yd. and over; Hoists, Elevators, outside type rack and pinion and similar machines; Hoists, One, Two and Three Drum; Hoists, Two Tugger One Floor; Hydraulic Backhoes; Hydraulic Boom Trucks; Hydro Vac (and similar equipment); Locomotives, All; Motor Patrol; Lubrication Technician; Manipulators; Pile Drivers and Skid Rig; Post Hole Digger; Pre-Stress Machine; Pump Cretes Dual Ram; Pump Cretes: Squeeze Cretes-Screw Type Pumps; Gypsum Bulker and Pump; Raised and Blind Hole Drill; Roto Mill Grinder; Scoops - Tractor Drawn; Slip-Form Paver; Straddle Buggies; Operation of Tie Back Machine; Tournapull; Tractor with Boom and Side Boom; Trenching

Machines.

Class 2. Boilers; Broom, All Power Propelled; Bulldozers; Concrete Mixer (Two Bag and Over); Conveyor, Portable; Forklift Trucks; Highlift Shovels or Front Endloaders under 2-1/4 yd.; Hoists, Automatic; Hoists, Inside Elevators; Hoists, Sewer Dragging Machine; Hoists, Tugger Single Drum; Laser Screed; Rock Drill (Self-Propelled); Rock Drill (Truck Mounted); Rollers, All; Steam Generators; Tractors, All; Tractor Drawn Vibratory Roller; Winch Trucks with "A" Frame.

Class 3. Air Compressor; Combination Small Equipment Operator; Generators; Heaters, Mechanical; Hoists, Inside Elevators (remodeling or renovation work); Hydraulic Power Units (Pile Driving, Extracting, and Drilling); Pumps, over 3" (1 to 3 not to exceed a total of 300 ft.); Low Boys; Pumps, Well Points; Welding Machines (2 through 5); Winches, 4 Small Electric Drill Winches.

Class 4. Bobcats and/or other Skid Steer Loaders; Oilers; and Brick Forklift.

Class 5. Assistant Craft Foreman.

Class 6. Gradall.

Class 7. Mechanics; Welders.

OPERATING ENGINEERS - HIGHWAY CONSTRUCTION

Class 1. Asphalt Plant; Asphalt Heater and Planer Combination; Asphalt Heater Scarfire; Asphalt Spreader; Autograder/GOMACO or other similar type machines: ABG Paver; Backhoes with Caisson Attachment; Ballast Regulator; Belt Loader; Caisson Rigs; Car Dumper; Central Redi-Mix Plant; Combination Backhoe Front Endloader Machine, (1 cu. yd. Backhoe Bucket or over or with attachments); Concrete Breaker (Truck Mounted); Concrete Conveyor; Concrete Paver over 27E cu. ft.; Concrete Placer; Concrete Tube Float; Cranes, all attachments; Cranes, Tower Cranes of all types: Creter Crane: Spider Crane; Crusher, Stone, etc.; Derricks, All; Derrick Boats; Derricks, Traveling; Dredges; Elevators, Outside type Rack & Pinion and Similar Machines; Formless Curb and Gutter Machine; Grader, Elevating; Grader, Motor Grader, Motor Patrol, Auto Patrol, Form Grader, Pull Grader, Subgrader; Guard Rail Post Driver Truck Mounted; Hoists, One, Two and Three Drum; Heavy Duty Self-Propelled Transporter or Prime Mover; Hydraulic Backhoes; Backhoes with shear attachments up to 40' of boom reach; Lubrication Technician; Manipulators; Mucking Machine; Pile Drivers and Skid Rig; Pre-Stress Machine; Pump Cretes Dual Ram; Rock Drill - Crawler or Skid Rig; Rock Drill - Truck Mounted; Rock/Track Tamper; Roto Mill Grinder; Slip-Form Paver; Snow Melters; Soil Test Drill Rig (Truck Mounted); Straddle Buggies; Hydraulic Telescoping Form (Tunnel); Operation of Tieback Machine; Tractor Drawn Belt Loader; Tractor Drawn Belt Loader (with attached pusher - two engineers); Tractor with Boom; Tractaire with Attachments; Traffic Barrier Transfer Machine; Trenching; Truck Mounted Concrete Pump with Boom; Raised or Blind Hole Drills (Tunnel Shaft); Underground Boring and/or Mining Machines 5 ft. in diameter and over tunnel, etc; Underground Boring and/or Mining Machines under 5 ft. in diameter; Wheel Excavator; Widener (APSCO).

Class 2. Batch Plant; Bituminous Mixer; Boiler and Throttle Valve; Bulldozers; Car Loader Trailing Conveyors; Combination Backhoe Front Endloader Machine (Less than 1 cu. yd. Backhoe Bucket or over or with attachments); Compressor and Throttle Valve; Compressor, Common Receiver (3); Concrete Breaker or Hydro Hammer; Concrete Grinding Machine; Concrete Mixer or Paver 7S Series to and including 27 cu. ft.; Concrete Spreader; Concrete Curing Machine, Burlap Machine, Belting Machine and Sealing Machine; Concrete Wheel Saw; Conveyor Muck Cars (Haglund or Similar Type); Drills, All; Finishing Machine - Concrete; Highlift Shovels or Front Endloader; Hoist - Sewer Dragging Machine; Hydraulic Boom Trucks (All Attachments); Hydro-Blaster; Hydro Excavating (excluding hose work); Laser Screed; All Locomotives, Dinky; Off-Road Hauling Units (including articulating) Non Self-Loading Ejection Dump; Pump Cretes: Squeeze Cretes - Screw Type Pumps, Gypsum Bulker and Pump; Roller, Asphalt; Rotary Snow Plows; Rototiller, Seaman, etc., self-propelled; Self-Propelled Compactor; Spreader - Chip - Stone, etc.; Scraper - Single/Twin Engine/Push and Pull; Scraper - Prime Mover in Tandem (Regardless of Size); Tractors pulling attachments, Sheeps Foot, Disc, Compactor, etc.; Tug Boats.

Class 3. Boilers; Brooms, All Power Propelled; Cement Supply Tender; Compressor, Common Receiver (2); Concrete Mixer (Two

Bag and Over); Conveyor, Portable; Farm-Type Tractors Used for Mowing, Seeding, etc.; Forklift Trucks; Grouting Machine; Hoists, Automatic; Hoists, All Elevators; Hoists, Tugger Single Drum; Jeep Diggers; Low Boys; Pipe Jacking Machines; Post-Hole Digger; Power Saw, Concrete Power Driven; Pug Mills; Rollers, other than Asphalt; Seed and Straw Blower; Steam Generators; Stump Machine; Winch Trucks with "A" Frame; Work Boats; Tamper-Form-Motor Driven.

Class 4. Air Compressor; Combination - Small Equipment Operator; Directional Boring Machine; Generators; Heaters, Mechanical; Hydraulic Power Unit (Pile Driving, Extracting, or Drilling); Light Plants, All (1 through 5); Pumps, over 3" (1 to 3 not to exceed a total of 300 ft.); Pumps, Well Points; Vacuum Trucks (excluding hose work); Welding Machines (2 through 5); Winches, 4 Small Electric Drill Winches.

Class 5. SkidSteer Loader (all); Brick Forklifts; Oilers.

Class 6. Field Mechanics and Field Welders

Class 7. Dowell Machine with Air Compressor; Gradall and machines of like nature.

OPERATING ENGINEER - FLOATING

Diver. Diver Wet Tender, Diver Tender, ROV Pilot, ROV Tender

TRUCK DRIVER - BUILDING, HEAVY AND HIGHWAY CONSTRUCTION

Class 1. Two or three Axle Trucks. A-frame Truck when used for transportation purposes; Air Compressors and Welding Machines, including those pulled by cars, pick-up trucks and tractors; Ambulances; Batch Gate Lockers; Batch Hopperman; Car and Truck Washers; Carry-alls; Fork Lifts and Hoisters; Helpers; Mechanics Helpers and Greasers; Oil Distributors 2-man operation; Pavement Breakers; Pole Trailer, up to 40 feet; Power Mower Tractors; Self-propelled Chip Spreader; Skipman; Slurry Trucks, 2-man operation; Slurry Truck Conveyor Operation, 2 or 3 man; Teamsters; Unskilled Dumpman; and Truck Drivers hauling warning lights, barricades, and portable toilets on the job site.

Class 2. Four axle trucks; Dump Crets and Adgetors under 7 yards; Dumpsters, Track Trucks, Euclids, Hug Bottom Dump Turnapulls or Turntrailers when pulling other than self-loading equipment or similar equipment under 16 cubic yards; Mixer Trucks under 7 yards; Ready-mix Plant Hopper Operator, and Winch Trucks, 2 Axles.

Class 3. Five axle trucks; Dump Crets and Adgetors 7 yards and over; Dumpsters, Track Trucks, Euclids, Hug Bottom Dump Turntrailers or turnapulls when pulling other than self-loading equipment or similar equipment over 16 cubic yards; Explosives and/or Fission Material Trucks; Mixer Trucks 7 yards or over; Mobile Cranes while in transit; Oil Distributors, 1-man operation; Pole Trailer, over 40 feet; Pole and Expandable Trailers hauling material over 50 feet long; Slurry trucks, 1-man operation; Winch trucks, 3 axles or more; Mechanic--Truck Welder and Truck Painter.

Class 4. Six axle trucks; Dual-purpose vehicles, such as mounted crane trucks with hoist and accessories; Foreman; Master Mechanic; Self-loading equipment like P.B. and trucks with scoops on the front.

TERRAZZO FINISHER

The handling of sand, cement, marble chips, and all other materials that may be used by the Mosaic Terrazzo Mechanic, and the mixing, grinding, grouting, cleaning and sealing of all Marble, Mosaic, and Terrazzo work, floors, base, stairs, and wainscoting by hand or machine, and in addition, assisting and aiding Marble, Masonic, and Terrazzo Mechanics.

Other Classifications of Work:

For definitions of classifications not otherwise set out, the Department generally has on file such definitions which are available. If a task to be performed is not subject to one of the classifications of pay set out, the Department will upon being contacted state

which neighboring county has such a classification and provide such rate, such rate being deemed to exist by reference in this document. If no neighboring county rate applies to the task, the Department shall undertake a special determination, such special determination being then deemed to have existed under this determination. If a project requires these, or any classification not listed, please contact IDOL at 217-782-1710 for wage rates or clarifications.

LANDSCAPING

Landscaping work falls under the existing classifications for laborer, operating engineer and truck driver. The work performed by landscape plantsman and landscape laborer is covered by the existing classification of laborer. The work performed by landscape operators (regardless of equipment used or its size) is covered by the classifications of operating engineer. The work performed by landscape truck drivers (regardless of size of truck driven) is covered by the classifications of truck driver.

MATERIAL TESTER & MATERIAL TESTER/INSPECTOR I AND II

Notwithstanding the difference in the classification title, the classification entitled "Material Tester I" involves the same job duties as the classification entitled "Material Tester/Inspector I". Likewise, the classification entitled "Material Tester II" involves the same job duties as the classification entitled "Material Tester/Inspector II".

COMPENSABLE DELAY COSTS (BDE)

Effective: June 2, 2017

Revised: April 1, 2019

Revise Article 107.40(b) of the Standard Specifications to read:

“(b) Compensation. Compensation will not be allowed for delays, inconveniences, or damages sustained by the Contractor from conflicts with facilities not meeting the above definition; or if a conflict with a utility in an unanticipated location does not cause a shutdown of the work or a documentable reduction in the rate of progress exceeding the limits set herein. The provisions of Article 104.03 notwithstanding, compensation for delays caused by a utility in an unanticipated location will be paid according to the provisions of this Article governing minor and major delays or reduced rate of production which are defined as follows.

- (1) Minor Delay. A minor delay occurs when the work in conflict with the utility in an unanticipated location is completely stopped for more than two hours, but not to exceed two weeks.
- (2) Major Delay. A major delay occurs when the work in conflict with the utility in an unanticipated location is completely stopped for more than two weeks.
- (3) Reduced Rate of Production Delay. A reduced rate of production delay occurs when the rate of production on the work in conflict with the utility in an unanticipated location decreases by more than 25 percent and lasts longer than seven calendar days.”

Revise Article 107.40(c) of the Standard Specifications to read:

“(c) Payment. Payment for Minor, Major, and Reduced Rate of Production Delays will be made as follows.

- (1) Minor Delay. Labor idled which cannot be used on other work will be paid for according to Article 109.04(b)(1) and (2) for the time between start of the delay and the minimum remaining hours in the work shift required by the prevailing practice in the area.

Equipment idled which cannot be used on other work, and which is authorized to standby on the project site by the Engineer, will be paid for according to Article 109.04(b)(4).

- (2) Major Delay. Labor will be the same as for a minor delay.

Equipment will be the same as for a minor delay, except Contractor-owned equipment will be limited to two weeks plus the cost of move-out to either the

Contractor's yard or another job and the cost to re-mobilize, whichever is less. Rental equipment may be paid for longer than two weeks provided the Contractor presents adequate support to the Department (including lease agreement) to show retaining equipment on the job is the most economical course to follow and in the public interest.

- (3) Reduced Rate of Production Delay. The Contractor will be compensated for the reduced productivity for labor and equipment time in excess of the 25 percent threshold for that portion of the delay in excess of seven calendar days. Determination of compensation will be in accordance with Article 104.02, except labor and material additives will not be permitted.

Payment for escalated material costs, escalated labor costs, extended project overhead, and extended traffic control will be determined according to Article 109.13."

Revise Article 108.04(b) of the Standard Specifications to read:

"(b) No working day will be charged under the following conditions.

- (1) When adverse weather prevents work on the controlling item.
- (2) When job conditions due to recent weather prevent work on the controlling item.
- (3) When conduct or lack of conduct by the Department or its consultants, representatives, officers, agents, or employees; delay by the Department in making the site available; or delay in furnishing any items required to be furnished to the Contractor by the Department prevents work on the controlling item.
- (4) When delays caused by utility or railroad adjustments prevent work on the controlling item.
- (5) When strikes, lock-outs, extraordinary delays in transportation, or inability to procure critical materials prevent work on the controlling item, as long as these delays are not due to any fault of the Contractor.
- (6) When any condition over which the Contractor has no control prevents work on the controlling item."

Revise Article 109.09(f) of the Standard Specifications to read:

"(f) Basis of Payment. After resolution of a claim in favor of the Contractor, any adjustment in time required for the work will be made according to Section 108. Any adjustment in the costs to be paid will be made for direct labor, direct materials, direct equipment, direct jobsite overhead, direct offsite overhead, and other direct costs allowed by the resolution. Adjustments in costs will not be made for interest charges, loss of anticipated profit, undocumented loss of efficiency, home office overhead and unabsorbed overhead

other than as allowed by Article 109.13, lost opportunity, preparation of claim expenses and other consequential indirect costs regardless of method of calculation.

The above Basis of Payment is an essential element of the contract and the claim cost recovery of the Contractor shall be so limited.”

Add the following to Section 109 of the Standard Specifications.

“109.13 Payment for Contract Delay. Compensation for escalated material costs, escalated labor costs, extended project overhead, and extended traffic control will be allowed when such costs result from a delay meeting the criteria in the following table.

Contract Type	Cause of Delay	Length of Delay
Working Days	Article 108.04(b)(3) or Article 108.04(b)(4)	No working days have been charged for two consecutive weeks.
Completion Date	Article 108.08(b)(1) or Article 108.08(b)(7)	The Contractor has been granted a minimum two week extension of contract time, according to Article 108.08.

Payment for each of the various costs will be according to the following.

- (a) Escalated Material and/or Labor Costs. When the delay causes work, which would have otherwise been completed, to be done after material and/or labor costs have increased, such increases will be paid. Payment for escalated material costs will be limited to the increased costs substantiated by documentation furnished by the Contractor. Payment for escalated labor costs will be limited to those items in Article 109.04(b)(1) and (2), except the 35 percent and 10 percent additives will not be permitted.
- (b) Extended Project Overhead. For the duration of the delay, payment for extended project overhead will be paid as follows.
 - (1) Direct Jobsite and Offsite Overhead. Payment for documented direct jobsite overhead and documented direct offsite overhead, including onsite supervisory and administrative personnel, will be allowed according to the following table.

Original Contract Amount	Supervisory and Administrative Personnel
Up to \$5,000,000	One Project Superintendent
Over \$ 5,000,000 - up to \$25,000,000	One Project Manager, One Project Superintendent or Engineer, and One Clerk
Over \$25,000,000 - up to \$50,000,000	One Project Manager, One Project Superintendent, One Engineer, and

	One Clerk
Over \$50,000,000	One Project Manager, Two Project Superintendents, One Engineer, and One Clerk

(2) Home Office and Unabsorbed Overhead. Payment for home office and unabsorbed overhead will be calculated as 8 percent of the total delay cost.

(c) Extended Traffic Control. Traffic control required for an extended period of time due to the delay will be paid for according to Article 109.04.

When an extended traffic control adjustment is paid under this provision, an adjusted unit price as provided for in Article 701.20(a) for increase or decrease in the value of work by more than ten percent will not be paid.

Upon payment for a contract delay under this provision, the Contractor shall assign subrogation rights to the Department for the Department's efforts of recovery from any other party for monies paid by the Department as a result of any claim under this provision. The Contractor shall fully cooperate with the Department in its efforts to recover from another party any money paid to the Contractor for delay damages under this provision."

CONSTRUCTION AIR QUALITY – DIESEL RETROFIT (BDE)

Effective: June 1, 2010

Revised: November 1, 2014

The reduction of emissions of particulate matter (PM) for off-road equipment shall be accomplished by installing retrofit emission control devices. The term “equipment” refers to diesel fuel powered devices rated at 50 hp and above, to be used on the jobsite in excess of seven calendar days over the course of the construction period on the jobsite (including rental equipment).

Contractor and subcontractor diesel powered off-road equipment assigned to the contract shall be retrofitted using the phased in approach shown below. Equipment that is of a model year older than the year given for that equipment’s respective horsepower range shall be retrofitted:

Effective Dates	Horsepower Range	Model Year
June 1, 2010 ^{1/}	600-749	2002
	750 and up	2006
June 1, 2011 ^{2/}	100-299	2003
	300-599	2001
	600-749	2002
	750 and up	2006
June 1, 2012 ^{2/}	50-99	2004
	100-299	2003
	300-599	2001
	600-749	2002
	750 and up	2006

1/ Effective dates apply to Contractor diesel powered off-road equipment assigned to the contract.

2/ Effective dates apply to Contractor and subcontractor diesel powered off-road equipment assigned to the contract.

The retrofit emission control devices shall achieve a minimum PM emission reduction of 50 percent and shall be:

- a) Included on the U.S. Environmental Protection Agency (USEPA) *Verified Retrofit Technology List* (<http://www.epa.gov/cleandiesel/verification/verif-list.htm>), or verified by the California Air Resources Board (CARB) (<http://www.arb.ca.gov/diesel/verdev/vt/cvt.htm>); or
- b) Retrofitted with a non-verified diesel retrofit emission control device if verified retrofit emission control devices are not available for equipment proposed to be used on the project, and if the Contractor has obtained a performance certification from the retrofit

device manufacturer that the emission control device provides a minimum PM emission reduction of 50 percent.

Note: Large cranes (Crawler mounted cranes) which are responsible for critical lift operations are exempt from installing retrofit emission control devices if such devices adversely affect equipment operation.

Diesel powered off-road equipment with engine ratings of 50 hp and above, which are unable to be retrofitted with verified emission control devices or if performance certifications are not available which will achieve a minimum 50 percent PM reduction, may be granted a waiver by the Department if documentation is provided showing good faith efforts were made by the Contractor to retrofit the equipment.

Construction shall not proceed until the Contractor submits a certified list of the diesel powered off-road equipment that will be used, and as necessary, retrofitted with emission control devices. The list(s) shall include (1) the equipment number, type, make, Contractor/rental company name; and (2) the emission control devices make, model, USEPA or CARB verification number, or performance certification from the retrofit device manufacturer. Equipment reported as fitted with emissions control devices shall be made available to the Engineer for visual inspection of the device installation, prior to being used on the jobsite.

The Contractor shall submit an updated list of retrofitted off-road construction equipment as retrofitted equipment changes or comes on to the jobsite. The addition or deletion of any diesel powered equipment shall be included on the updated list.

If any diesel powered off-road equipment is found to be in non-compliance with any portion of this special provision, the Engineer will issue the Contractor a diesel retrofit deficiency deduction.

Any costs associated with retrofitting any diesel powered off-road equipment with emission control devices shall be considered as included in the contract unit prices bid for the various items of work involved and no additional compensation will be allowed. The Contractor's compliance with this notice and any associated regulations shall not be grounds for a claim.

Diesel Retrofit Deficiency Deduction

When the Engineer determines that a diesel retrofit deficiency exists, a daily monetary deduction will be imposed for each calendar day or fraction thereof the deficiency continues to exist. The calendar day(s) will begin when the time period for correction is exceeded and end with the Engineer's written acceptance of the correction. The daily monetary deduction will be \$1,000.00 for each deficiency identified.

The deficiency will be based on lack of diesel retrofit emissions control.

If a Contractor accumulates three diesel retrofit deficiency deductions for the same piece of equipment in a contract period, the Contractor will be shutdown until the deficiency is corrected.

Such a shutdown will not be grounds for any extension of the contract time, waiver of penalties, or be grounds for any claim.

80261

HOT-MIX ASPHALT – PATCHING (BDE)

Effective: April 1, 2022

Replace Article 442.08(b) of the Standard Specifications with the following:

“(b) Density. The density of the compacted HMA shall be according to Articles 1030.06, 1030.09(b), 1030.09(c), and 1030.09(f).”

80444

HOT-MIX ASPHALT – START OF PRODUCTION (BDE)

Effective: January 1, 2022

Add the following paragraph between the third and four paragraphs of Article 1030.10 of the Standard Specifications:

“When a test strip is not required, each HMA mixture with a quantity of 3,000 tons (2,750 metric tons) or more shall still be sampled on the first day of production: I-FIT and Hamburg wheel testing for High ESAL; I-FIT testing for Low ESAL. Within two working days after sampling the mixture, the Contractor shall deliver gyratory cylinders to the District laboratory for Department verification testing. The High ESAL mixture test results shall meet the requirements of Articles 1030.05(d)(3) and 1030.05(d)(4). The Low ESAL mixture test results shall meet the requirements of Article 1030.05(d)(4).”

80442

SUBCONTRACTOR MOBILIZATION PAYMENTS (BDE)

Effective: November 2, 2017

Revised: April 1, 2019

Replace the second paragraph of Article 109.12 of the Standard Specifications with the following:

“This mobilization payment shall be made at least seven days prior to the subcontractor starting work. The amount paid shall be at the following percentage of the amount of the subcontract reported on form BC 260A submitted for the approval of the subcontractor’s work.

Value of Subcontract Reported on Form BC 260A	Mobilization Percentage
Less than \$10,000	25%
\$10,000 to less than \$20,000	20%
\$20,000 to less than \$40,000	18%
\$40,000 to less than \$60,000	16%
\$60,000 to less than \$80,000	14%
\$80,000 to less than \$100,000	12%
\$100,000 to less than \$250,000	10%
\$250,000 to less than \$500,000	9%
\$500,000 to \$750,000	8%
Over \$750,000	7%”

80391

VEHICLE AND EQUIPMENT WARNING LIGHTS (BDE)

Effective: November 1, 2021

Add the following paragraph after the first paragraph of Article 701.08 of the Standard Specifications:

“The Contractor shall equip all vehicles and equipment with high-intensity oscillating, rotating, or flashing, amber or amber-and-white, warning lights which are visible from all directions. The lights shall be in operation while the vehicle or equipment is engaged in construction operations.”

80439

WORK ZONE TRAFFIC CONTROL DEVICES (BDE)

Effective: March 2, 2020

Add the following to Article 701.03 of the Standard Specifications:

“(q) Temporary Sign Supports 1106.02”

Revise the third paragraph of Article 701.14 of the Standard Specifications to read:

“For temporary sign supports, the Contractor shall provide a FHWA eligibility letter for each device used on the contract. The letter shall provide information for the set-up and use of the device as well as a detailed drawing of the device. The signs shall be supported within 20 degrees of vertical. Weights used to stabilize signs shall be attached to the sign support per the manufacturer’s specifications.”

Revise the first paragraph of Article 701.15 of the Standard Specifications to read:

“**701.15 Traffic Control Devices.** For devices that must meet crashworthiness standards, the Contractor shall provide a manufacturer’s self-certification or a FHWA eligibility letter for each Category 1 device and a FHWA eligibility letter for each Category 2 and Category 3 device used on the contract. The self-certification or letter shall provide information for the set-up and use of the device as well as a detailed drawing of the device.”

Revise the first six paragraphs of Article 1106.02 of the Standard Specifications to read:

“**1106.02 Devices.** Work zone traffic control devices and combinations of devices shall meet crashworthiness standards for their respective categories. The categories are as follows.

Category 1 includes small, lightweight, channelizing and delineating devices that have been in common use for many years and are known to be crashworthy by crash testing of similar devices or years of demonstrable safe performance. These include cones, tubular markers, plastic drums, and delineators, with no attachments (e.g. lights). Category 1 devices manufactured after December 31, 2019 shall be MASH-16 compliant. Category 1 devices manufactured on or before December 31, 2019, and compliant with NCHRP 350 or MASH 2009, may be used on contracts let before December 31, 2024.

Category 2 includes devices that are not expected to produce significant vehicular velocity change but may otherwise be hazardous. These include vertical panels with lights, barricades, temporary sign supports, and Category 1 devices with attachments (e.g. drums with lights). Category 2 devices manufactured after December 31, 2019 shall be MASH-16 compliant. Category 2 devices manufactured on or before December 31, 2019, and compliant with NCHRP 350 or MASH 2009, may be used on contracts let before December 31, 2024.

Category 3 includes devices that are expected to cause significant velocity changes or other potentially harmful reactions to impacting vehicles. These include crash cushions (impact

attenuators), truck mounted attenuators, and other devices not meeting the definitions of Category 1 or 2. Category 3 devices manufactured after December 31, 2019 shall be MASH-16 compliant. Category 3 devices manufactured on or before December 31, 2019, and compliant with NCHRP 350 or MASH 2009, may be used on contracts let before December 31, 2029. Category 3 devices shall be crash tested for Test Level 3 or the test level specified.

Category 4 includes portable or trailer-mounted devices such as arrow boards, changeable message signs, temporary traffic signals, and area lighting supports. It is preferable for Category 4 devices manufactured after December 31, 2019 to be MASH-16 compliant; however, there are currently no crash tested devices in this category, so it remains exempt from the NCHRP 350 or MASH compliance requirement.

For each type of device, when no more than one MASH-16 compliant is available, an NCHRP 350 or MASH-2009 compliant device may be used, even if manufactured after December 31, 2019.”

Revise Articles 1106.02(g), 1106.02(k), and 1106.02(l) to read:

“(g) Truck Mounted/Trailer Mounted Attenuators. The attenuator shall be approved for use at Test Level 3. Test Level 2 may be used for normal posted speeds less than or equal to 45 mph.

(k) Temporary Water Filled Barrier. The water filled barrier shall be a lightweight plastic shell designed to accept water ballast and be on the Department’s qualified product list.

Shop drawings shall be furnished by the manufacturer and shall indicate the deflection of the barrier as determined by acceptance testing; the configuration of the barrier in that test; and the vehicle weight, velocity, and angle of impact of the deflection test. The Engineer shall be provided one copy of the shop drawings.

(l) Movable Traffic Barrier. The movable traffic barrier shall be on the Department’s qualified product list.

Shop drawings shall be furnished by the manufacturer and shall indicate the deflection of the barrier as determined by acceptance testing; the configuration of the barrier in that test; and the vehicle weight, velocity, and angle of impact of the deflection test. The Engineer shall be provided one copy of the shop drawings. The barrier shall be capable of being moved on and off the roadway on a daily basis.”

State of Illinois
Department of Transportation
Bureau of Local Roads and Streets

SPECIAL PROVISION
FOR
RAILROAD PROTECTIVE LIABILITY INSURANCE FOR LOCAL LETTINGS

Effective: March 1, 2005
Revised: January 1, 2006

All references to Sections or Articles in this specification shall be construed to mean a specific Section or Article of the Standard Specifications for Road and Bridge Construction, adopted by the Department of Transportation.

Railroad Protective Liability Insurance. The contractor will be required to carry Railroad Protective Liability and Property Damage Liability Insurance in accordance with Article 107.11 of the Standard Specifications. A separate policy is required for each railroad indicated on the attached form unless otherwise noted. The limits of liability for each policy are listed on the attached form. The minimum limits of liability shall be in accordance with Article 107.11 of the Standard Specifications.

Basis of Payment. The costs for providing insurance, as noted above, will be paid for at the contract unit price per Lump Sum for RAILROAD PROTECTIVE LIABILITY INSURANCE.

APPROVAL OF INSURANCE: The ORIGINAL and one CERTIFIED copy of each required policy shall be submitted for approval to the following address:

CN - thomas.brasseur@cn.ca

UP - as requested

The contractor will be advised when approval of the insurance has been received from the railroad(s). Before any work begins on railroad right-of-way, the Contractor shall submit to the Resident Engineer evidence that the required railroad protective liability insurance has been approved by the railroad(s). The Contractor shall also provide the Resident Engineer with expiration date of each required policy.

RAILROAD PROTECTIVE LIABILITY INSURANCE FORM

<u>NAMED INSURED & ADDRESS</u>	<u>NUMBER & SPEED OF PASSENGER TRAINS</u>	<u>NUMBER & SPEED OF FREIGHT TRAINS</u>
------------------------------------	---	---

See CN Railroad Certificate of Insurance Example in the special provisions.

4 - 50 mph

DOT/AAR Number: 289 891 V RR Mile Post: 29.70
Liability Limits: Combined Single Limit \$ 5,000,000 Aggregate Limit \$ 10,000,000
For Freight/Passenger Information Contact: _____ Phone: _____
For Insurance Information Contact: Thomas Brasseur Phone: 715-544-9145

See CN Railroad Certificate of Insurance Example in the special provisions.

4 - 50 mph

DOT/AAR Number: 289 890 N RR Mile Post: 29.55
Liability Limits: Combined Single Limit \$ 5,000,000 Aggregate Limit \$ 10,000,000
For Freight/Passenger Information Contact: _____ Phone: _____
For Insurance Information Contact: Thomas Brasseur Phone: 715-544-9145

See Union Pacific Insurance Requirements in the special provisions.

0 - 5 mph

DOT/AAR Number: 175 891 D RR Mile Post: 31.57
Liability Limits: Combined Single Limit \$ 5,000,000 Aggregate Limit \$ 10,000,000
For Freight/Passenger Information Contact: _____ Phone: _____
For Insurance Information Contact: _____ Phone: _____

DOT/AAR Number: _____ RR Mile Post: _____
Liability Limits: Combined Single Limit \$ _____ Aggregate Limit \$ _____
For Freight/Passenger Information Contact: _____ Phone: _____
For Insurance Information Contact: _____ Phone: _____

State of Illinois
DEPARTMENT OF TRANSPORTATION
Bureau of Local Roads and Streets

SPECIAL PROVISION
FOR
BITUMINOUS MATERIALS COST ADJUSTMENT FOR LOCAL LETTINGS

(RETURN FORM WITH BID)

Effective: June 16, 2017

Revised:

Description. Bituminous material cost adjustments will be made to provide additional compensation to the Contractor, or credit to the project owner, for fluctuations in the cost of bituminous materials when optioned by the Contractor. The bidder shall indicate on the attached form whether or not this special provision will be part of the contract and submit the completed form with his/her bid. Failure to submit the form, or failure to fill out the form completely, shall make this contract exempt of bituminous materials cost adjustments.

The adjustments shall apply to permanent and temporary hot-mix asphalt (HMA) mixtures, bituminous surface treatments (cover and seal coats), and preventative maintenance type surface treatments that are part of the original proposed construction, or added as extra work and paid for by agreed unit prices. The adjustments shall not apply to bituminous prime coats, tack coats, crack filling/sealing, joint filling/sealing, or extra work paid for at a lump sum price or by force account.

Method of Adjustment. Bituminous materials cost adjustments will be computed as follows.

$$CA = (BPI_P - BPI_L) \times (\%AC_V / 100) \times Q$$

Where: CA = Cost Adjustment, \$.

BPI_P = Bituminous Price Index, as published by the Department of Transportation for the month the work is performed, \$/ton (\$/metric ton).

BPI_L = Bituminous Price Index, as published by the Department of Transportation for the month prior to the letting for work paid for at the contract price; or for the month the agreed unit price letter is submitted by the Contractor for extra work paid for by agreed unit price, \$/ton (\$/metric ton).

%AC_V = Percent of virgin Asphalt Cement in the Quantity being adjusted. For HMA mixtures, the % AC_V will be determined from the adjusted job mix formula. For bituminous materials applied, a performance graded or cutback asphalt will be considered to be 100% AC_V and undiluted emulsified asphalt will be considered to be 65% AC_V.

Q = Authorized construction Quantity, tons (metric tons) (see below).

For HMA mixtures measured in square yards: $Q, \text{ tons} = A \times D \times (G_{mb} \times 46.8) / 2000$. For HMA mixtures measured in square meters: $Q, \text{ metric tons} = A \times D \times (G_{mb} \times 1) / 1000$. When computing adjustments for full-depth HMA pavement, separate calculations will be made for the binder and surface courses to account for their different G_{mb} and $\% AC_V$.

For bituminous materials measured in gallons: $Q, \text{ tons} = V \times 8.33 \text{ lb/gal} \times SG / 2000$
For bituminous materials measured in liters: $Q, \text{ metric tons} = V \times 1.0 \text{ kg/L} \times SG / 1000$

Where: A = Area of the HMA mixture, sq yd (sq m).
D = Depth of the HMA mixture, in. (mm).
 G_{mb} = Average bulk specific gravity of the mixture, from the approved mix design.
V = Volume of the bituminous material, gal (L).
SG = Specific Gravity of bituminous material as shown on the bill of lading.

Basis of Payment. Bituminous materials cost adjustments may be positive or negative but will only be made when there is a difference between the BPI_L and BPI_P in excess of five percent, as calculated by:

$$\text{Percent Difference} = \{(BPI_L - BPI_P) \div BPI_L\} \times 100$$

Bituminous materials cost adjustments will be calculated for each calendar month in which applicable bituminous material is placed; and will be paid or deducted when all other contract requirements for the work placed during the month are satisfied. The adjustments shall not apply during contract time subject to liquidated damages for completion of the entire contract.

State of Illinois
DEPARTMENT OF TRANSPORTATION
Bureau of Local Roads and Streets

SPECIAL PROVISION
FOR
FUEL COST ADJUSTMENT FOR LOCAL LETTINGS

(RETURN FORM WITH BID)

Effective: June 16, 2017

Revised:

Description. Fuel cost adjustments will be made to provide additional compensation to the Contractor, or a credit to the project owner, for fluctuations in fuel prices when optioned by the Contractor. The bidder shall indicate on the attached form whether or not this special provision will be part of the contract and submit the completed form with his/her bid. Failure to submit the form or failure to indicate contract number, company name and sign and date the form shall make this contract exempt of fuel cost adjustments for all categories of work. Failure to indicate "Yes" for any category of work will make that category of work exempt from fuel cost adjustment.

General. The fuel cost adjustment shall apply to contract pay items as grouped by category. The adjustment shall only apply to those categories of work checked "Yes", and only when the cumulative plan quantities for a category exceed the required threshold. Adjustments to work items in a category, either up or down, and extra work paid for by agreed unit price will be subject to fuel cost adjustment only when the category representing the added work was subject to the fuel cost adjustment. Extra work paid for at a lump sum price or by force account will not be subject to fuel cost adjustment. Category descriptions and thresholds for application and the fuel usage factors which are applicable to each are as follows:

(a) Categories of Work.

- (1) Category A: Earthwork. Contract pay items performed under Sections 202, 204, and 206 of the IDOT Standard Specifications for Road and Bridge Construction including any modified standard or nonstandard items where the character of the work to be performed is considered earthwork. The cumulative total of all applicable item plan quantities shall exceed 25,000 cu yd (20,000 cu m). Included in the fuel usage factor is a weighted average 0.10 gal/cu yd (0.50 liters/cu m) factor for trucking.
- (2) Category B: Subbases and Aggregate Base Courses. Contract pay items constructed under Sections 311, 312 and 351 of the IDOT Standard Specifications for Road and Bridge Construction including any modified standard or nonstandard items where the character of the work to be performed is considered construction of a subbase or aggregate, stabilized or modified base course. The cumulative total of all applicable item plan quantities shall exceed 5000 tons (4500 metric tons). Included in the fuel usage factor is a 0.60 gal/ton (2.50 liters/metric ton) factor for trucking.

- (3) Category C: Hot-Mix Asphalt (HMA) Bases, Pavements and Shoulders. Contract pay items constructed under Sections 355, 406, 407 and 482 of the IDOT Standard Specifications for Road and Bridge Construction including any modified standard or nonstandard items where the character of the work to be performed is considered HMA bases, pavements and shoulders. The cumulative total of all applicable item plan quantities shall exceed 5000 tons (4500 metric tons). Included in the fuel usage factor is 0.60 gal/ton (2.50 liters/metric ton) factor for trucking.
- (4) Category D: Portland Cement Concrete (PCC) Bases, Pavements and Shoulders. Contract pay items constructed under Sections 353, 420, 421 and 483 of the IDOT Standard Specifications for Road and Bridge Construction including any modified standard or nonstandard items where the character of the work to be performed is considered PCC base, pavement or shoulder. The cumulative total of all applicable item plan quantities shall exceed 7500 sq yd (6000 sq m). Included in the fuel usage factor is 1.20 gal/cu yd (5.94 liters/cu m) factor for trucking.
- (5) Category E: Structures. Structure items having a cumulative bid price that exceeds \$250,000 for pay items constructed under Sections 502, 503, 504, 505, 512, 516 and 540 of the IDOT Standard Specifications for Road and Bridge Construction including any modified standard or nonstandard items where the character of the work to be performed is considered structure work when similar to that performed under these sections and not included in categories A through D.

(b) Fuel Usage Factors.

English Units Category	Factor	Units
A - Earthwork	0.34	gal / cu yd
B – Subbase and Aggregate Base courses	0.62	gal / ton
C – HMA Bases, Pavements and Shoulders	1.05	gal / ton
D – PCC Bases, Pavements and Shoulders	2.53	gal / cu yd
E – Structures	8.00	gal / \$1000

Metric Units Category	Factor	Units
A - Earthwork	1.68	liters / cu m
B – Subbase and Aggregate Base courses	2.58	liters / metric ton
C – HMA Bases, Pavements and Shoulders	4.37	liters / metric ton
D – PCC Bases, Pavements and Shoulders	12.52	liters / cu m
E – Structures	30.28	liters / \$1000

(c) Quantity Conversion Factors.

Category	Conversion	Factor
B	sq yd to ton	0.057 ton / sq yd / in depth
	sq m to metric ton	0.00243 metric ton / sq m / mm depth
C	sq yd to ton	0.056 ton / sq yd / in depth
	sq m to metric ton	0.00239 m ton / sq m / mm depth
D	sq yd to cu yd	0.028 cu yd / sq yd / in depth
	sq m to cu m	0.001 cu m / sq m / mm depth

Method of Adjustment. Fuel cost adjustments will be computed as follows.

$$CA = (FPI_P - FPI_L) \times FUF \times Q$$

Where: CA = Cost Adjustment, \$

FPI_P = Fuel Price Index, as published by the Department of Transportation for the month the work is performed, \$/gal (\$/liter)

FPI_L = Fuel Price Index, as published by the Department of Transportation for the month prior to the letting for work paid for at the contract price; or for the month the agreed unit price letter is submitted by the Contractor for extra work paid for by agreed unit price, \$/gal (\$/liter)

FUF = Fuel Usage Factor in the pay item(s) being adjusted

Q = Authorized construction Quantity, tons (metric tons) or cu yd (cu m)

The entire FUF indicated in paragraph (b) will be used regardless of use of trucking to perform the work.

Basis of Payment. Fuel cost adjustments may be positive or negative but will only be made when there is a difference between the FPI_L and FPI_P in excess of five percent, as calculated by:

$$\text{Percent Difference} = \{(FPI_L - FPI_P) \div FPI_L\} \times 100$$

Fuel cost adjustments will be calculated for each calendar month in which applicable work is performed; and will be paid or deducted when all other contract requirements for the items of work are satisfied. The adjustments shall not apply during contract time subject to liquidated damages for completion of the entire contract.

State of Illinois
DEPARTMENT OF TRANSPORTATION
Bureau of Local Roads & Streets
SPECIAL PROVISION
FOR
LOCAL QUALITY ASSURANCE/ QUALITY MANAGEMENT QC/QA
Effective: January 1, 2022

Replace the first five paragraphs of Article 1030.06 of the Standard Specifications with the following:

“1030.06 Quality Management Program. The Quality Management Program (QMP) will be Quality Control / Quality Assurance (QC/QA) according to the following.”

Delete Article 1030.06(d)(1) of the Standard Specifications.

Revise Article 1030.09(g)(3) of the Standard Specifications to read:

“(3) If core testing is the density verification method, the Contractor shall provide personnel and equipment to collect density verification cores for the Engineer. Core locations will be determined by the Engineer following the document “Hot-Mix Asphalt QC/QA Procedure for Determining Random Density Locations” at density verification intervals defined in Article 1030.09(b). After the Engineer identifies a density verification location and prior to opening to traffic, the Contractor shall cut a 4 in. (100 mm) diameter core. With the approval of the Engineer, the cores may be cut at a later time.”

Revise Article 1030.09(h)(2) of the Standard Specifications to read:

“(2) After final rolling and prior to paving subsequent lifts, the Engineer will identify the random density verification test locations. Cores or nuclear density gauge testing will be used for density verification. The method used for density verification will be as selected below.

Density Verification Method	
<input type="checkbox"/>	Cores
<input checked="" type="checkbox"/>	Nuclear Density Gauge (Correlated when paving \geq 3,000 tons per mixture)

Density verification test locations will be determined according to the document “Hot-Mix Asphalt QC/QA Procedure for Determining Random Density Locations”. The density testing interval for paving wider than or equal to 3 ft (1 m) will be 0.5 miles (800 m) for lift thicknesses of 3 in. (75 mm) or less and 0.2 miles (320 m) for lift thicknesses greater than 3 in. (75 mm). The density testing interval for paving less than 3 ft (1 m) wide will be 1 mile (1,600 m). If a day’s paving will be less than the prescribed density testing interval, the length of the day’s paving will be the interval for that day. The density testing interval for mixtures used for patching will be 50 patches with a minimum of one test per mixture per project.

If core testing is the density verification method, the Engineer will witness the Contractor coring, and secure and take possession of all density samples at the

density verification locations. The Engineer will test the cores collected by the Contractor for density according to Illinois Modified AASHTO T 166 or AASHTO T 275.

If nuclear density gauge testing is the density verification method, the Engineer will conduct nuclear density gauge tests. The Engineer will follow the density testing procedure detailed in the document "Illinois Modified ASTM D 2950, Standard Test Method for Density of Bituminous Concrete In-Place by Nuclear Method".

A density verification test will be the result of a single core or the average of the nuclear density tests at one location. The results of each density test must be within acceptable limits. The Engineer will promptly notify the Contractor of observed deficiencies."

Revise the seventh paragraph and all subsequent paragraphs in Section D. of the document "Hot-Mix Asphalt QC/QA Initial Daily Plant and Random Samples" to read:

"Mixtures shall be sampled from the truck at the plant by the Contractor following the same procedure used to collect QC mixture samples (Section A). This process will be witnessed by the Engineer who will take custody of the verification sample. Each sample bag with a verification mixture sample will be secured by the Engineer using a locking ID tag. Sample boxes containing the verification mixture sample will be sealed/taped by the Engineer using a security ID label."

**HIGHWAY STANDARD DRAWINGS
DuPAGE COUNTY DETAILS
IDOT DISTRICT ONE DETAILS**





ABV	ABOVE	CU YD	CUBIC YARD	HATCH	HATCHING	PMI	PAVEMENT MARKING	STD	STANDARD
A/C	ACCESS CONTROL	CULV	CULVERT	HD	HEAD	PED	PEDESTAL	SBI	STATE BOND ISSUE
AC	AGRE	G&G	CURB & GUTTER	HDW	HEADWALL	PNT	POINT	SR	STATION
ADJ	ADJUST	D	DEGREE OF CURVE	HDUY	HEAVY DUTY	PC	POINT OF INTERSECTION OF HORIZONTAL CURVE	STA	STEEL PLATE BEAM GUARDRAIL
AS	AERIAL SURVEYS	DC	DEPRESSOR	ha	HECTARE	PI	POINT OF INTERSECTION OF HORIZONTAL CURVE	SPBGR	STORM SEWER
AGG	AGGREGATE	DET	DETECTOR	HMA	HOT MIX ASPHALT	PRC	POINT OF REVERSE CURVE	SS	STORY
AH	AHEAD	DIA	DIAMETER	HORIZ	HORIZONTAL	PT	POINT ON TANGENT	ST	STREET
APT	APARTMENT	DIST	DISTRICT	HSE	HOUSE	PRC	POINT OF REVERSE CURVE	STR	STRUCTURE
ASPH	ASPHALT	DOM	DOMESTIC	IL	ILLINOIS	POT	POINT ON TANGENT	e	SUPERELEVATION RATE
AUX	AUXILIARY	DBL	DOUBLE	IMP	IMPROVEMENT	PCC	POLYETHYLENE	S.E. RUN	SUPERELEVATION RUNOFF LENGTH
AUX	AUXILIARY GAS VALVE (SERVICE)	DSEL	DOWNSTREAM ELEVATION	IN DIA	INCH DIAMETER	PP	PORTLAND CEMENT CONCRETE	SURF	SURFACE
AVE	AVENUE	DSFL	DOWNSTREAM FLOWLINE	INL	INLET	PRM	PRIVATE ENTRANCE	SHK	SURVEY MARKER
AX	AXIS OF ROTATION	DR	DRAINAGE OR DRIVE	INST	INSTALLATION	PE	PROFILE	T	TANGENT DISTANCE
BK	BACK	DRV	DRAINAGE INLET OR DROP INLET	IDS	INTERSECTION DESIGN STUDY	PROF	PROFILE	T.R.	TANGENT RUNOUT DISTANCE
BB	BACK TO BACK	DRV	DRAINAGE INLET OR DROP INLET	INVT	INVERT	POL	POLY GRADELINE	TEL	TELEPHONE
BBL	BARRIQUADE	FACT	FACTORY	IP	IRON PIPE	PROJ	PROPERTY CORNER	TEL	TELEPHONE BOX
BARR	BARRIQUADE	E	EASTBOUND	IR	IRON ROD	PCOI	PROPERTY CORNER	TP	TEMPORARY
BL	BASELINE	EG	EDGE OF PAVEMENT	IT	JOINT	PL	PROPOSED LINE	TEMP	TEMPORARY BENCH MARK
BGN	BEGIN	EOP	EDGE OF PAVEMENT	K	KILOGRAM	R	RADIUS OR RESIDENTIAL	TBM	TILE DRAIN
BLM	BENCHMARK	E-CL	EDGE TO CENTERLINE	km	KILOMETER	RR	RAILROAD SPIKE	TBR	TO BE EXTENDED
BM	BENCHMARK	E-E	EDGE TO EDGE	LN	LANE	RRS	RAILROAD SPIKE	TBE	TO BE EXTENDED
BND	BINDER	ELEC	ELECTRICAL	LS	LANDSCAPING	RPS	REFERENCE POINT STAKE	TBS	TO BE SAVED
BIT	BITUMINOUS	ELEV	ELEVATION	LN	LANE	REF	REFLECTIVE	TWP	TOWNSHIP
BTM	BOTTOM	ENTR	ENTRANCE	LT	LEFT	RCCP	REINFORCED CONCRETE CULVERT PIPE	TR	TOWNSHIP ROAD
BTD	BOULEVARD	EXC	EXCAVATION	LDAR	LIGHT DETECTION AND RANGING	REIN	REINFORCEMENT	TS	TRAFFIC SIGNAL
BRK	BRICK	EX	EXISTING	LGT	LIGHT POLE	REM	REMOVAL	TSCB	TRAFFIC SIGNAL CONTROL BOX
BROX	BROX	EXPWAY	EXPRESSWAY	LF	LITER OR LINEAR FEET	RC	REMOVE CROWN	TSC	TRAFFIC SYSTEMS CENTER
BULD	BUILDING	E	EXTERNAL DISTANCE OF HORIZONTAL CURVE	L	LITER OR LINEAR FEET	REP	REPLACEMENT	TRVS	TRANSVERSE
CABLE	CABLE	F-F	FACE TO FACE	LC	LONG CHORD	RESUR	RESURFACING	TRVL	TRAVEL
CB	CAST IRON PIPE	F	FEDERAL AID	LONG	LONGITUDINAL	REST	RESTAURANT	TRN	TURN
C-B	CATCH BASIN	F-A	FEDERAL AID INTERSTATE	L SUM	LUMP SUM	RET	RETAINING	TY	TYPE
C-C	CENTER TO CENTER	FAP	FEDERAL AID PRIMARY	MACH	MACHINE	RT	RIGHT-OF-WAY	T-A	TYPICAL
CL	CENTERLINE OR CLEARANCE	FAS	FEDERAL AID SECONDARY	MH	MANHOLE	ROW	ROAD	TYP	TYPICAL
CL-E	CENTERLINE TO EDGE	FAS	FEDERAL AID SECONDARY	MATL	MATERIAL	RD	ROADWAY	UNDGND	UNDERGROUND
CL-F	CENTERLINE TO FACE	FAUS	FEDERAL AID URBAN SECONDARY	MED	MEDIAN	RTE	ROUTE	USGS	U.S. GEOLOGICAL SURVEY
CTS	CENTERS	FAUS	FEDERAL AID URBAN SECONDARY	METH	METHOD	RDWY	ROADWAY	USEL	UPSTREAM ELEVATION
CERT	CERTIFIED	FP	FIBER POST	M	METER	SAN	SANITARY SEWER	UTIL	UTILITY
CHSLD	CHESEBROUGH	OPT	OPTIC	M	MILLIMETER	SEC	SECTION	VBOX	VALVE BOX
CS	CITY STREET	FE	FIELD ENTRANCE	mm	MILLIMETER	SEED	SEEDING	VV	VALVE VAULT
CP	CLAY PIPE	FF	FIRE HYDRANT	MIX	MIXTURE	S	SHAP	VLT	VAULT
CLD	CLOSED	FL	FLOW LINE	MBH	MOBILE HOME	SH	SHOULDER	VEH	VEHICLE
CLSD	CLOSED	FB	FOOT BRIDGE	MOD	MODIFIED	SHLD	SHOULDER	VENT	VENT PIPE
CLUD	CLOSED	FDN	FOUNDATION	MFT	MOTOR FUEL TAX	SW	SIDEWALK OR SOUTHWEST	VERT	VERTICAL
CT	COAT OR COURT	FR	FRAME	N & BC	NAIL & BOTTLE CAP	SIG	SIGNAL	VC	VERTICAL CURVE
COMB	COMBINATION	F&G	FRAME & GRATE	N & C	NAIL & CAP	SOD	SODDING	VPC	VERTICAL POINT OF INTERSECTION
C	COMMERCIAL BUILDING	GAL	GALLON	N & W	NAIL & WASHER	SB	SOLID MEDIUM	VPT	VERTICAL POINT OF TANGENCY
CE	CONCRETE	GALV	GALVANIZED	NC	NORTHBOUND	SE	SOUTHBOUND	WM	WATER METER
CONC	CONCRETE	G	GARAGE	NE	NORTHBOUND	SPL	SPECIAL	WV	WATER VALVE
CONST	CONSTRUCT	GM	GAS METER	NO	NORTHWEST	SO	SPECIAL	WMAIN	WATER MAIN
CONTD	CONTINUED	GIS	GEOGRAPHICAL INFORMATION SYSTEM	O/S	OFFSET	SD	SPECIAL	WB	WESTBOUND
CONT	CONTINUED	GR	GRATE	O&C	OIL AND CHIP	SQ FT	SQUARE FEET	W	WITHOUT
COR	CORNER	GRV	GRAVEL	OLID	OPEN LID	mm ²	SQUARE MILLIMETER	W	WITHOUT
CORR	CORRUGATED	GND	GROUND	PAT	PATTERN	mm ²	SQUARE MILLIMETER	W	WITHOUT
CMP	CORRUGATED METAL PIPE	GUT	GUTTER	PAVED	PAVED	mm ²	SQUARE MILLIMETER	W	WITHOUT
CNTY	COUNTY	GW	GUY WIRE	PVMT	PAVEMENT	STB	STABILIZED	W	WITHOUT
CH	COUNTY HIGHWAY	HH	HANDHOLE						
CSE	COURSE								
CSE	COURSE								
XSECT	CROSS SECTION								
mm	CUBIC METER								
mm ³	CUBIC MILLIMETER								

STANDARD SYMBOLS, ABBREVIATIONS AND PATTERNS

(Sheet 1 of 9)

DATE	REVISIONS
1-1-21	Updated fonts, abbreviations and symbols.
1-1-19	Added new symbols.

 Illinois Department of Transportation	ISSUED 1-1-07
	PASSED January 1, 2021  ENGINEER OF POLICY AND PROCEDURES
	APPROVED January 1, 2021  ENGINEER OF DESIGN AND ENVIRONMENT
	STANDARD 000001-08

<u>ADJUSTMENT ITEMS</u>	<u>EX</u>	<u>PR</u>
Structure To Be Adjusted		
Structure To Be Cleaned		
Main Structure To Be Filled		
Structure To Be Filled		
Structure To Be Filled Special		
Structure To Be Removed		
Structure To Be Reconstructed		
Structure To Be Reconstructed Special		
Frame and Grate To Be Adjusted		
Frame and Lid To Be Adjusted		
Domestic Service Box To Be Adjusted		
Valve Vault To Be Adjusted		
Special Adjustment		
Item To Be Abandoned		
Item To Be Moved		
Item To Be Relocated		
Pavement Removal and Replacement		

<u>ALIGNMENT ITEMS</u>	<u>EX</u>	<u>PR</u>
Baseline		
Centerline		
Centerline Break Circle		
Baseline Symbol		
Centerline Symbol		
PI Indicator		
Point Indicator		
Horizontal Curve Data (Half Size)	EX CURVE P.L. STA= A.L. STA= D= R= L= E= T= S.E. RUN= P.C. STA= P.T. STA= PR CURVE P.L. STA= A.L. STA= D= R= L= E= T= S.E. RUN= P.C. STA= P.T. STA=	

<u>BOUNDARIES ITEMS</u>	<u>EX</u>	<u>PR</u>
Dashed Property Line		
Solid Property/Lot Line		
Section/Grant Line		
Quarter Section Line		
Quarter/Quarter Section Line		
County/Township Line		
State Line		
Chiseled Square Found		
Iron Pipe Found		
Iron Pipe Set		
Survey Marker		
Property Line Symbol		
Same Ownership Symbol (Half Size)		
Northwest Quarter Corner (Half Size)		
Section Corner (Half Size)		
Southeast Quarter Corner (Half Size)		

<u>DRAINAGE ITEMS</u>	<u>EX</u>	<u>PR</u>
Channel or Stream Line		
Culvert Line		
Grading & Shaping Ditches		
Drainage Boundary Line		
Paved Ditch		
Aggregate Ditch		
Pipe Underdrain		
Storm Sewer		
Flowline		
Ditch Check		
Headwall		
Inlet		
Manhole		
Summit		
Roadway Ditch Flow		
Swale		
Catch Basin		
Culvert End Section		
Water Surface Indicator		
Riprap		

<u>HYDRAULICS ITEMS</u>	<u>EX</u>	<u>PR</u>
Overflow		
Sheet Flow		
Hydrant Outlet		

STANDARD SYMBOLS, ABBREVIATIONS AND PATTERNS
(Sheet 2 of 9)

ILLINOIS Department of Transportation
 PASSED January 1, 2021
 APPROVED January 1, 2021
 ENGINEER OF POLICY AND PROCEDURES
 ENGINEER OF DESIGN AND ENVIRONMENT

ISSUED 1-1-07

STANDARD 000001-08

EROSION & SEDIMENT CONTROL ITEMS

Cleaning & Grading Limits

Dike

Erosion Control Fence

Perimeter Erosion Barrier

Temporary Fence

Ditch Check Temporary

Ditch Check Permanent

Inlet & Pipe Protection

Sediment Basin

Erosion Control Blanket

Fabric Formed Concrete
Revetment Mat

Turf Reinforcement Mat

Mulch Temporary

Mulch Method 1

Mulch Method 2 Stabilized

Mulch Method 3 Hydraulic

CONTOUR ITEMS

Approx. Index Line

Approx. Intermediate Line

Index Contour

Intermediate Contour

EX

PR

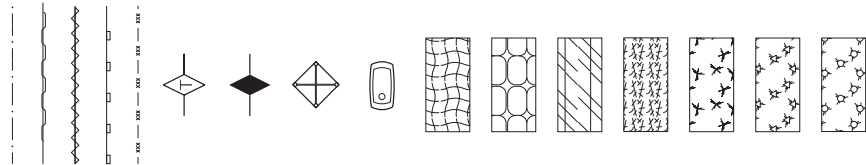

EX

PR

NON-HIGHWAY IMPROVEMENT ITEMS

Noise Attm./Levee

Field Line

Fence

Base of Levee

Mailbox

Multiple Mailboxes

Pay Telephone

Advertising Sign

ITS Camera

Wind Turbine

Cellular Tower

*Intelligent Transportation Systems

LANDSCAPING ITEMS

Contour Mounding Line

Fence

Fence Post

Shrubs

Mowline

Perennial Plants

Seeding Class 2

Seeding Class 2A

Seeding Class 4

Seeding Class 4 & 5 Combined

EX

PR



EX

PR

EXISTING LANDSCAPING ITEMS (contd.)

Seeding Class 5

Seeding Class 7

Seedlings Type 1

Seedlings Type 2

Sodding

Mowstake w/Sign

Tree Trunk Protection

Evergreen Tree

Shade Tree

LIGHTING

Duct

Conduit

Electrical Aerial Cable

Electrical Burled Cable

Controller

Underpass Luminaire

Power Pole

EX

PR

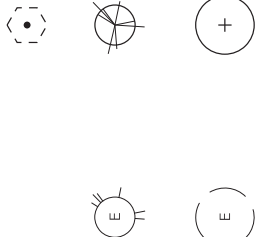
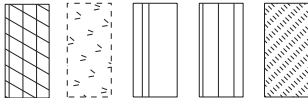

**STANDARD SYMBOLS,
ABBREVIATIONS
AND PATTERNS**
(Sheet 3 of 9)
STANDARD 000001-08

Illinois Department of Transportation
PASSED January 1, 2021
ENGINEER OF POLICY AND PROCEDURES
APPROVED January 1, 2021
ENGINEER OF DESIGN AND ENVIRONMENT

ISSUED 1-1-07

**LIGHTING
(contd.)**

Pull Point		
Handhole		
Heavy Duty Handhole		
Junction Box		
Light Unit Comb.		
Electrical Ground		
Traffic Flow Arrow		
High Mast Pole (Half Size)		
Light Unit-1		

PAVEMENT MARKINGS

Handicap Symbol		
RR Crossing		
Raised Marker Amber 1 Way		
Raised Marker Amber 2 Way		
Raised Marker Crystal 1 Way		
Two Way Turn Left		
Shoulder Diag. Pattern		
Skip-Dash White		
Skip-Dash Yellow		
Stop Line		
Solid Line		
Double Centerline		
Dotted Lines		

PR

EX

PAVEMENT (MISC.)

PR

EX

Keyed Long. Joint		
Keyed Long. Joint w/Tie Bars		
Sawed Long. Joint w/Tie Bars		
Bituminous Shoulder		
Bituminous Taper		
Stabilized Driveway		
Widening		

**STANDARD SYMBOLS,
ABBREVIATIONS
AND PATTERNS**
(Sheet 4 of 9)
STANDARD 000001-08

Illinois Department of Transportation
PASSED January 1, 2021
APPROVED January 1, 2021
ENGINEER OF POLICY AND PROCEDURES
ENGINEER OF DESIGN AND ENVIRONMENT

PAVEMENT MARKINGS
(contd.)

EX

PR

CL 2Ln 2Way
RRPW 12.2 m (40') o.c.



CL 2Ln 2Way
RRPW 80' (24.4 m) o.c.



CL Multilane Div.
RRPW 40' (12.2 m) o.c.



CL Multilane Div.
RRPW 80' (24.4 m) o.c.



CL Multilane Div. Dbl.
RRPW 80' (24.4 m) o.c.



CL Multilane Undiv.



Two Way Turn Left Line



Urban Combination Left



Urban Combination Right



Urban Left Turn Arrow



Urban Right Turn Arrow



Urban Left Turn Only



ONLY



Urban Right Turn Only



ONLY



Urban Thru Only



ONLY



Illinois Department of Transportation

PASSED January 1, 2021
 APPROVED January 1, 2021
 ENGINEER OF POLICY AND PROCEDURES
 ENGINEER OF DESIGN AND ENVIRONMENT

Urban LT & RT Turn Arrow

Urban Thru Arrow

ISSUED 1-1-07

RAILROAD ITEMS

PR

EX

Abandoned Railroad



Railroad

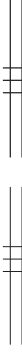

Railroad Point



Control Box



Crossing Gate



Flashing Signal



Railroad Cant. Mast Arm



Crossbuck



REMOVAL ITEMS

PR

EX

Removal Tic



Bituminous Removal



Hatch Pattern



Tree Removal Single



RIGHT OF WAY ITEMS

PR

EX

Future ROW Corner Monument



ROW Marker



ROW Line



Easement



Temporary Easement



**STANDARD SYMBOLS,
ABBREVIATIONS
AND PATTERNS**
(Sheet 5 of 9)

STANDARD 000001-08

PAVEMENT MARKINGS
(contd.)

Urban U-Turn				
Urban Combined U-Turn				
Rural Combination Left				
Rural Combination Right				
Rural Left Turn Arrow				
Rural Right Turn Arrow				
Rural Left Turn Only				
Rural Right Turn Only				
Rural Thru Only				
Rural Thru Arrow				
Rural Lt. & Rt Turn Arrow				
Bike Lane Symbol				
Bike Lane Text				
Bike Path Shared				
Bike Shared Roadway				
Lane Drop Symbol				

PR



ONLY ONLY ONLY

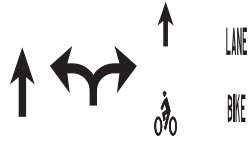

LANE
BWE



**STANDARD SYMBOLS,
ABBREVIATIONS
AND PATTERNS**
(Sheet 6 of 9)
STANDARD 000001-08

PAVEMENT MARKINGS
(contd.)

EX



Illinois Department of Transportation
PASSED January 1, 2021
[Signature]
ENGINEER OF POLICY AND PROCEDURES
APPROVED January 1, 2021
[Signature]
ENGINEER OF DESIGN AND ENVIRONMENT

Wrong Way Arrow

ISSUED 1-1-07

RIGHT OF WAY ITEMS
(contd.)

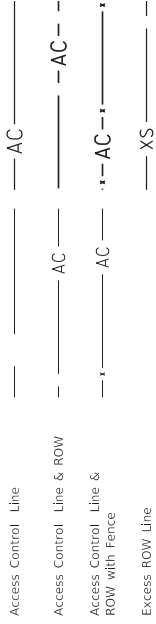

ROADWAY PLAN ITEMS

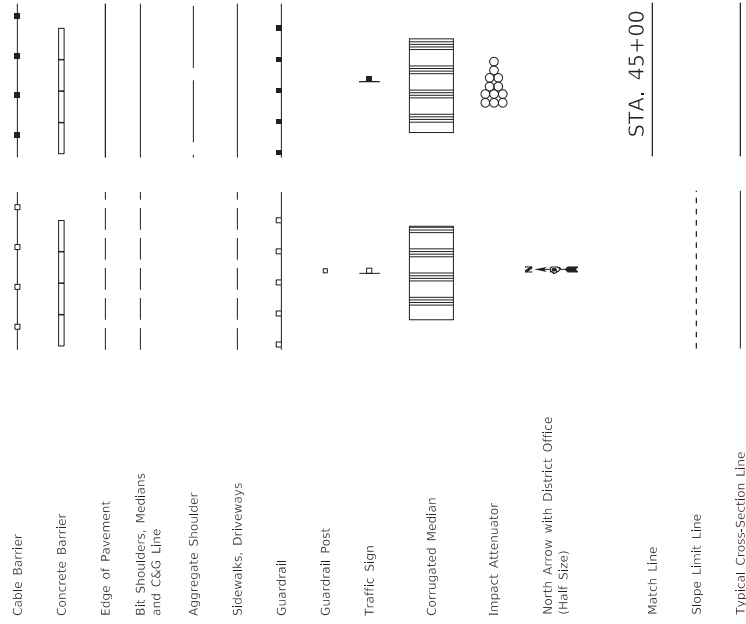

ROADWAY PROFILES

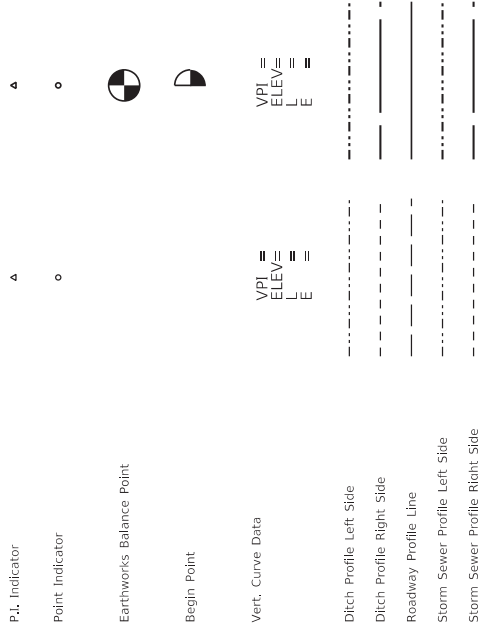

SIGNING ITEMS

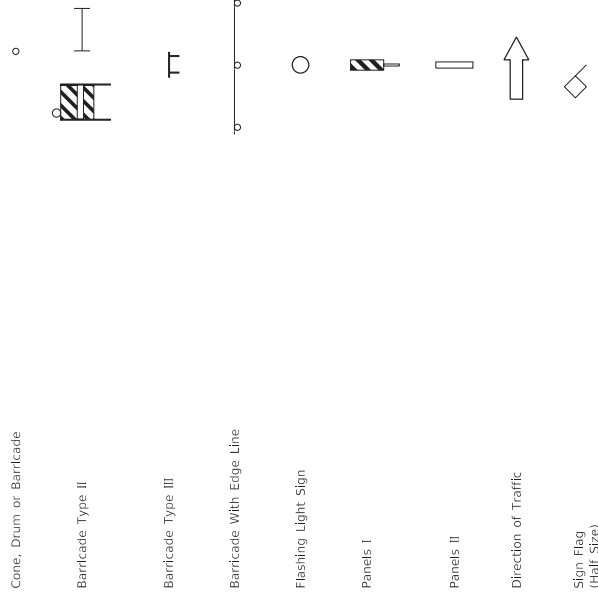

SIGNING ITEMS
(contd.)



ILLINOIS Department of Transportation
 PASSED January 1, 2021
 ENGINEER OF POLICY AND PROCEDURES
 APPROVED January 1, 2021
 ENGINEER OF DESIGN AND ENVIRONMENT

STANDARD SYMBOLS, ABBREVIATIONS AND PATTERNS
 (Sheet 7 of 9)
STANDARD 000001-08

SIGNING ITEMS
(contd.)

One Way Arrow Upr. W1-6-(O)
(Half Size)

Two Way Arrow Large W1-7-(O)
(Half Size)

Detour M4-10L-(O)
(Half Size)

Detour M4-10R-(O)
(Half Size)

One Way Left R6-1L
(Half Size)

One Way Right R6-1R
(Half Size)

Left Turn Lane R3-100L
(Half Size)

Keep Left R4-7AL
(Half Size)

Keep Left R4-7BL
(Half Size)

Keep Right R4-7AR
(Half Size)

Keep Right R4-7BR
(Half Size)

Stop Here On Red R10-6-AL
(Half Size)

Stop Here On Red R10-6-AR
(Half Size)

No Left Turn R3-2
(Half Size)

No Right Turn R3-1
(Half Size)

Road Closed R11-2
(Half Size)

Road Closed Thru Traffic R11-2
(Half Size)

STRUCTURES ITEMS

Box Culvert Barrel

Box Culvert Headwall

Bridge Pier

Bridge

Retaining Wall

Temporary Sheet Piling

TRAFFIC SHEET ITEMS

Cable Number

Left Turn Green

Left Turn Yellow

Signal Backplate

Signal Section 8" (200 mm)

Signal Section 12" (300 mm)

Walk/Don't Walk Letters

Walk/Don't Walk Symbols

TRAFFIC SIGNAL ITEMS

Galv. Steel Conduit

Underground Cable

Detector Loop Line

Detector Loop Large

Detector Loop Small

Detector Loop Quadrupole

PR



PR

EX



EX

EX



PR



PR



EX



**STANDARD SYMBOLS,
ABBREVIATIONS
AND PATTERNS**
(Sheet 8 of 9)
STANDARD 000001-08

Illinois Department of Transportation
ISSUED 1-1-07

PASSED January 1, 2021
[Signature]
ENGINEER OF POLICY AND PROCEDURES

APPROVED January 1, 2021
[Signature]
ENGINEER OF DESIGN AND ENVIRONMENT

TRAFFIC SIGNAL ITEMS (contd.)

	<u>EX</u>	<u>PR</u>
Detector Raceway		
Aluminum Mast Arm		
Steel Mast Arm		
Veh. Detector Magnetic		
Conduit- Splice		
Controller		
Gulfbbox Junction		
Wood Pole		
Temp. Signal Head		
Handhole		
Double Handhole		
Heavy Duty Handhole		
Junction Box		
Ped. Pushbutton Detector		
Ped. Signal Head		
Power Pole Service		
Priority Veh. Detector		
Signal Head		
Signal Head w/Backplate		
Signal Post		
Closed Circuit TV		
Video Detector System		

UNDERGROUND UTILITY ITEMS

	<u>EX</u>	<u>PR</u>	<u>ABANDONED</u>
Cable TV			
Electric Cable			
Fiber Optic			
Gas Pipe			
Oil Pipe			
Sanitary Sewer			
Telephone Cable			
Water Pipe			

UTILITIES ITEMS

	<u>EX</u>	<u>PR</u>
Controller		
Double Handhole		
Fire Hydrant		
GuyWire or Deadman Anchor		
Handhole		
Heavy Duty Handhole		
Junction Box		
Light Pole		
Manhole		
Monitoring Well (Gasoline)		
Pipeline Warning Sign		
Power Pole		
Power Pole with Light		
Sanitary Sewer Cleanout		
Splice Box Above Ground		
Telephone Splice Box Above Ground		
Telephone Pole		

UTILITY ITEMS (contd.)

	<u>EX</u>	<u>PR</u>
Traffic Signal		
Traffic Signal Control Box		
Water Meter		
Water Meter Valve Box		
Profile Line		
Aerial Power Line		

VEGETATION ITEMS

	<u>EX</u>	<u>PR</u>
Deciduous Tree		
Bush or Shrub		
Evergreen Tree		
Stump		
Orchard/Nursery Line		
Vegetation Line		
Woods & Bush Line		

WATER FEATURE ITEMS

	<u>EX</u>	<u>PR</u>
Stream or Drainage Ditch		
Waters Edge		
Water Surface Indicator		
Water Point		
Disappearing Ditch		
Marsh		
Marsh/Swamp Boundary		

Illinois Department of Transportation
 January 1, 2021
 PASSED

 ENGINEER OF POLICY AND PROCEDURES
 APPROVED
 January 1, 2021

 ENGINEER OF DESIGN AND ENVIRONMENT

**STANDARD SYMBOLS,
 ABBREVIATIONS
 AND PATTERNS**
 (Sheet 9 of 9)
STANDARD 000001-08

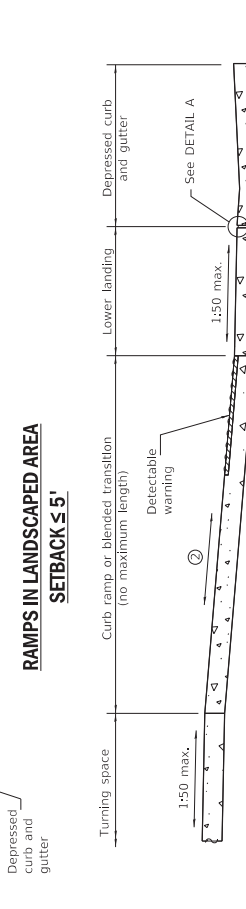
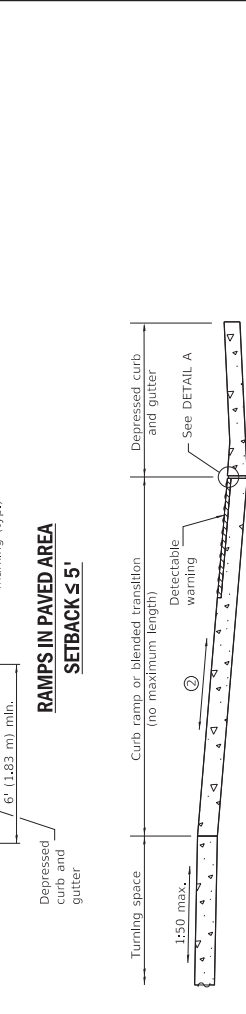
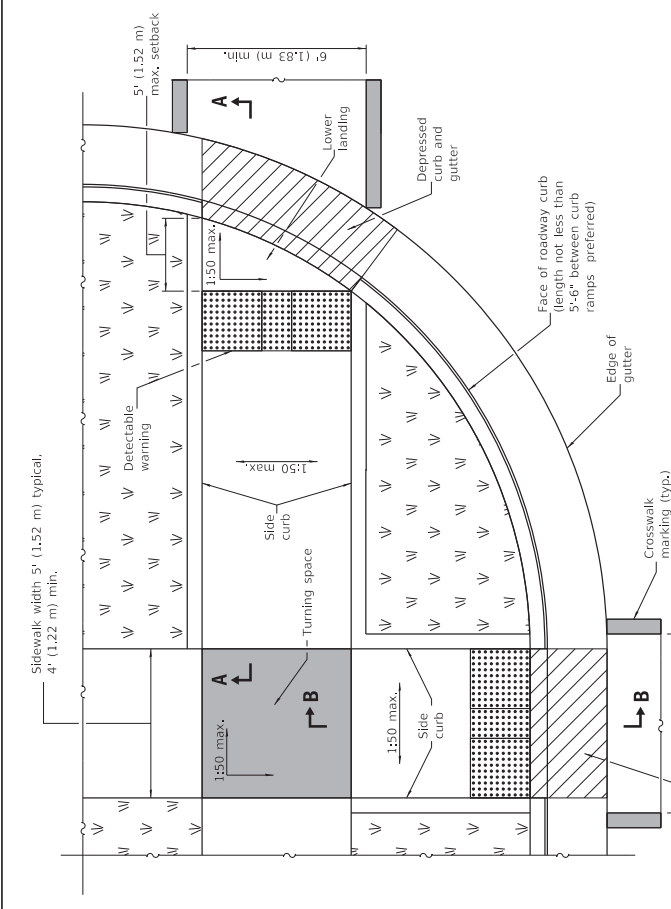
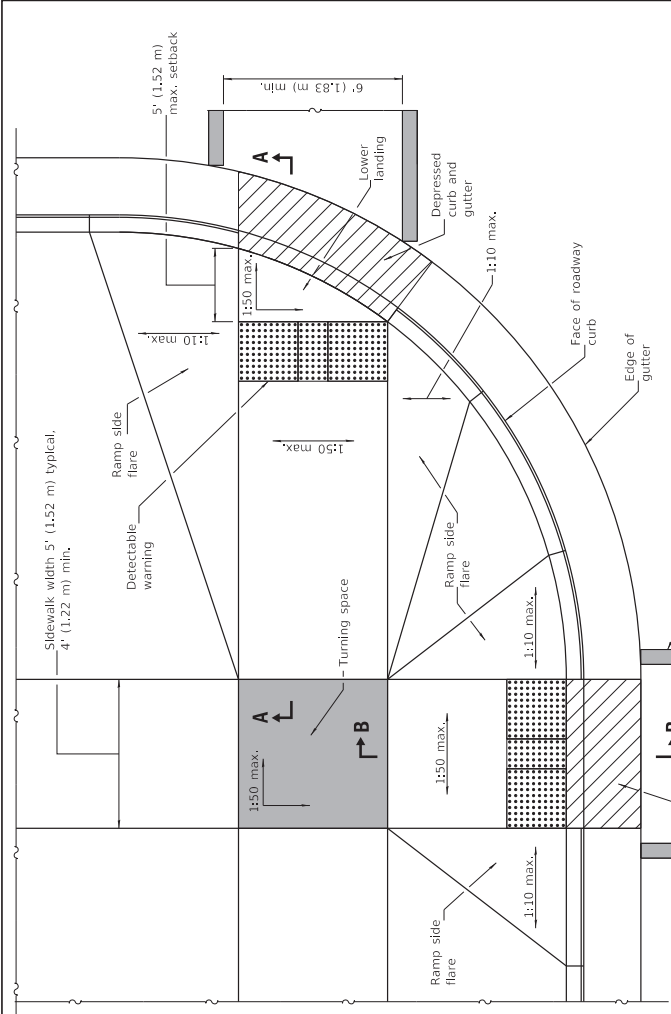

**RAMPS IN LANSCAPED AREA
SETBACK ≤ 5'**

② The running slope of a curb ramp shall be 1:20 min. and 1:12 max. The running slope of a blended transition shall be 1:20 max.

SECTION A-A

② The running slope of a curb ramp shall be 1:20 min. and 1:12 max. The running slope of a blended transition shall be 1:20 max.

SECTION B-B

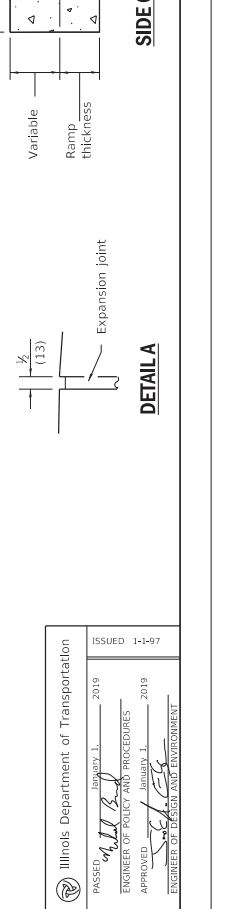
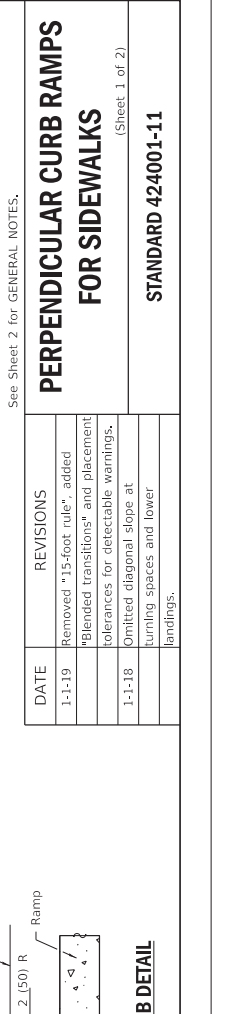

See Sheet 2 for GENERAL NOTES.

DATE	REVISIONS
1-1-19	Removed "15-foot rule", added "Blended transitions" and placement tolerances for detectable warnings.
1-1-18	Omitted diagonal slope at turning spaces and lower landings.

PERPENDICULAR CURB RAMPS FOR SIDEWALKS
(Sheet 1 of 2)

STANDARD 424001-11

PASSED JUNE 13, 2019 ENGINEER OF POLICY AND PROCEDURES APPROVED JUNE 13, 2019 ENGINEER OF DESIGN AND ENVIRONMENT	ISSUED 1-1-07
	Illinois Department of Transportation JUNE 13, 2019 ENGINEER OF POLICY AND PROCEDURES APPROVED JUNE 13, 2019 ENGINEER OF DESIGN AND ENVIRONMENT

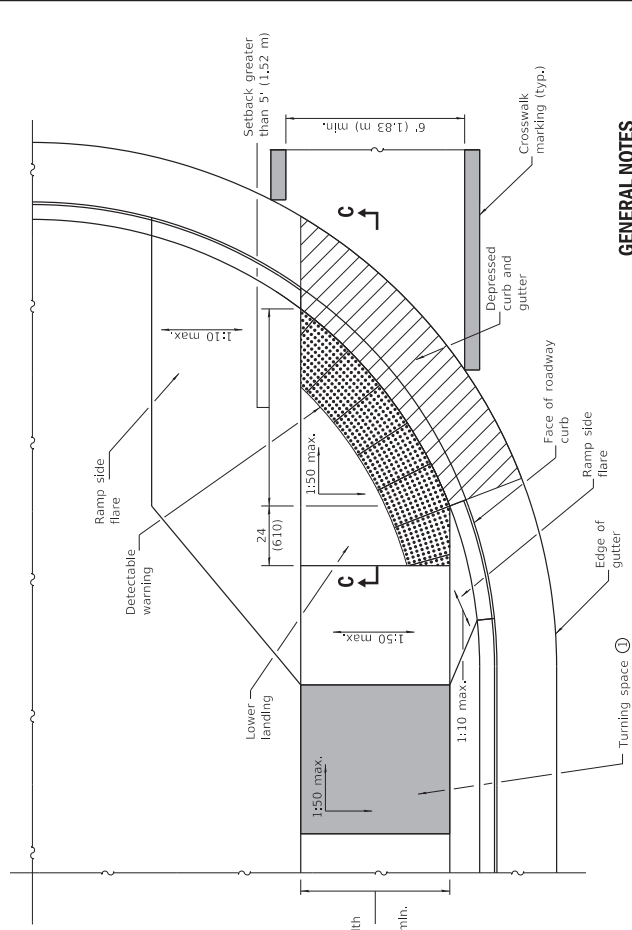

**RAMP IN LANDSCAPED AREA
SETBACK > 5'**

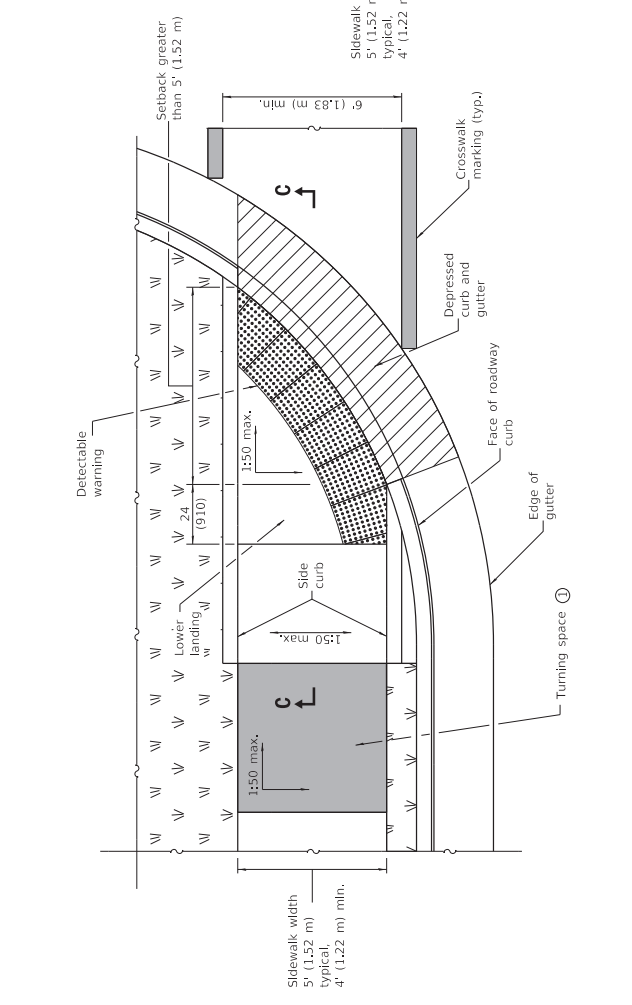

**RAMP IN PAVED AREA
SETBACK > 5'**

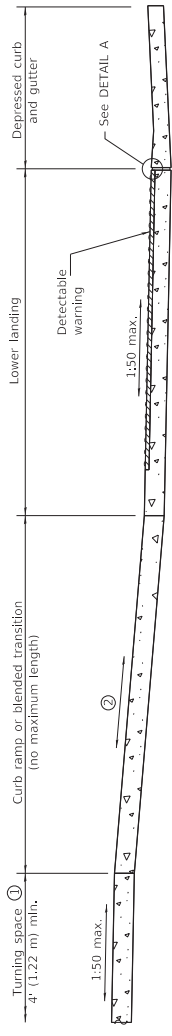

SECTION C-C

- ① This turning space not required for blended transitions.
- ② The running slope of a curb ramp shall be 1:20 min. and 1:12 max. The running slope of a blended transition shall be 1:20 max.

GENERAL NOTES

All slope ratios are expressed as units of vertical displacement to units of horizontal displacement (V/H).

Where the turning space is constrained on a side opposite a ramp, the minimum length of the turning space in the direction of the ramp-run shall be 5' (1.52 m).

Where 1:50 maximum slope is shown, 1:64 is preferred.

Detectable warnings are shown in their ideal locations but the following placement tolerances are allowed.

Side Border - Detectable warnings should extend the full width of the walking surface (excluding flared sides) but a border along each side up to 2 in. (50 mm) in width is allowed.

Curb Set-Back - Detectable warnings located at the back of curb should closely align with the curb but a gap up to 6 in. (150 mm) behind the curb is allowed.

See Standard 606001 for details of depressed curb adjacent to curb ramp.

All dimensions are in inches (millimeters) unless otherwise shown.

**PERPENDICULAR CURB RAMPS
FOR SIDEWALKS**
(Sheet 2 of 2)

STANDARD 424001-11

Illinois Department of Transportation
 PASSED: *[Signature]* January 1, 2019
 ENGINEER OF POLICY AND PROCEDURES
 APPROVED: *[Signature]* January 1, 2019
 ENGINEER OF DESIGN AND ENVIRONMENT

ISSUED 1-1-07

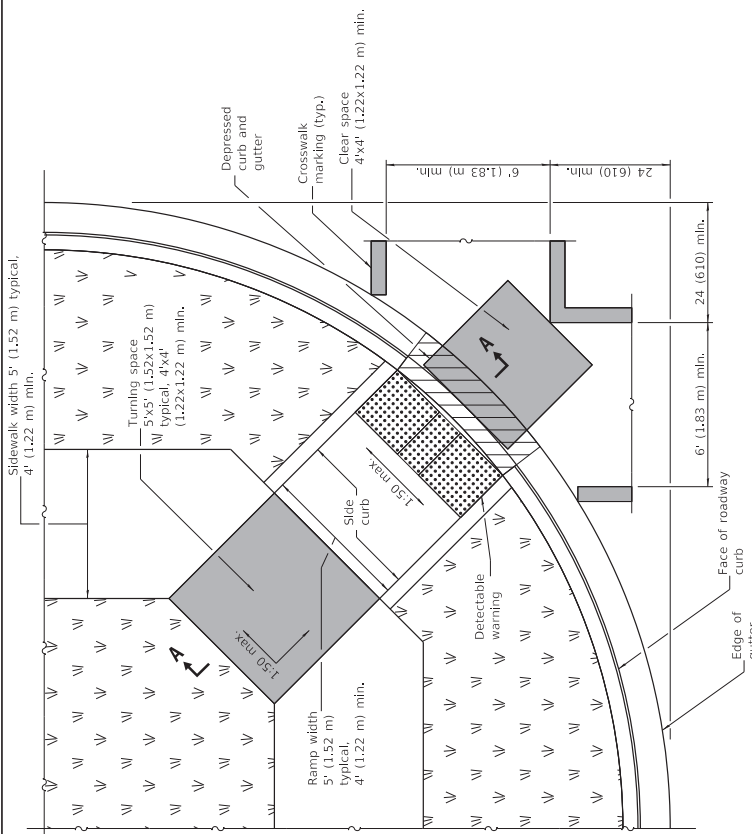

RAMP IN LANDSCAPED AREA

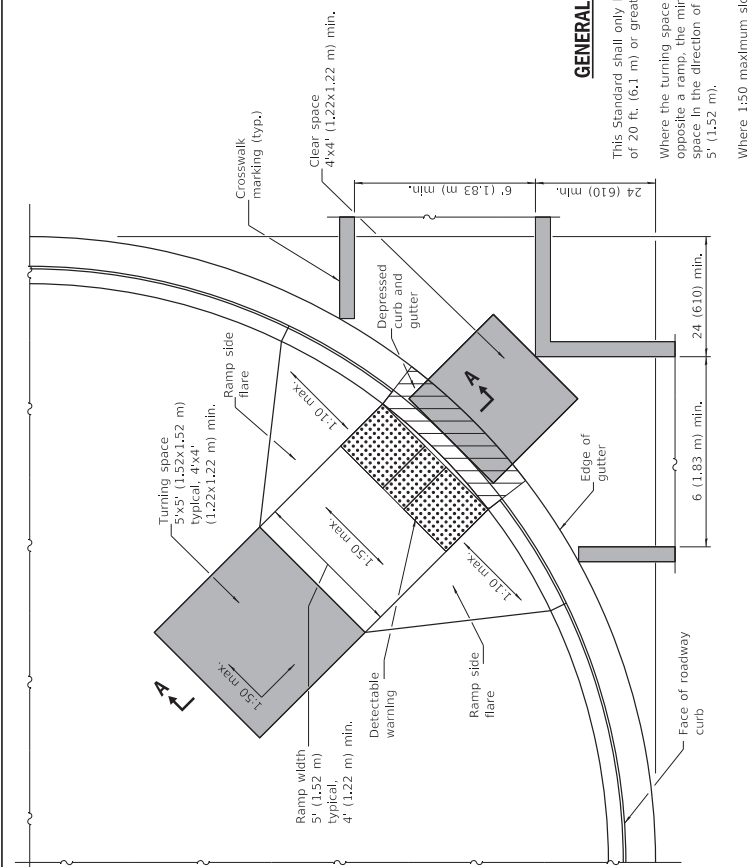

RAMP IN PAVED AREA

GENERAL NOTES

This Standard shall only be used for curb radii of 20 ft. (6.1 m) or greater.
 Where the turning space is constrained on a side opposite a ramp, the minimum length of the turning space in the direction of the ramp-run shall be 5' (1.52 m).
 Where 1:50 maximum slope is shown, 1:64 is preferred.
 Detectable warnings are shown in their ideal locations but the following placement tolerances are allowed.
 Side Border - Detectable warnings should extend the full width of the walking surface (excluding flared sides) but a border along each side up to 2 in. (50 mm) in width is allowed.
 Curb Set-Back - Detectable warnings located at the back of curb should closely align with the curb but a gap up to 6 in. (150 mm) behind the curb is allowed.
 All slope ratios are expressed as units of vertical displacement to units of horizontal displacement (V:H).
 See Standard 606001 for details of depressed curb adjacent to curb ramp.
 All dimensions are in inches (millimeters) unless otherwise shown.

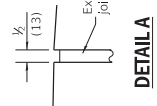

DETAIL A

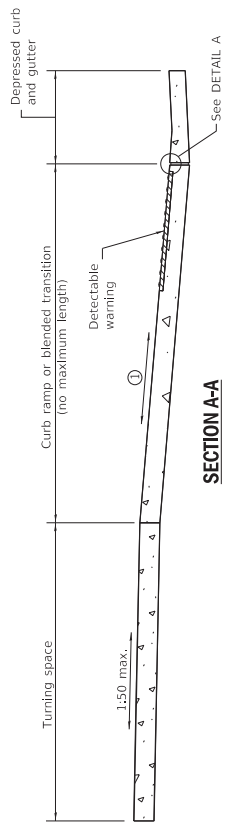

SECTION A-A

① The running slope of a curb ramp shall be 1:20 min. and 1:12 max. The running slope of a blended transition shall be 1:20 max.

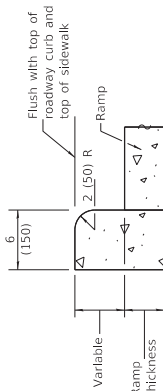

SIDE CURB DETAIL

Illinois Department of Transportation
 PASSED: [Signature] January 1, 2021
 ENGINEER OF POLICY AND PROCEDURES
 APPROVED: [Signature] January 1, 2021
 ENGINEER OF DESIGN AND ENVIRONMENT

DATE	REVISIONS
1-1-21	Clarified minimum crosswalk width and locations.
1-1-19	Removed "15-foot rule", added "blended transitions", and placement tolerances for detectable warnings.

DIAGONAL CURB RAMPS FOR SIDEWALKS
STANDARD 424006-05

Sidewalk width $\geq 7'$ (2.13 m)
 Typical, pedestrian access
 route width 4' (1.22 m) min.

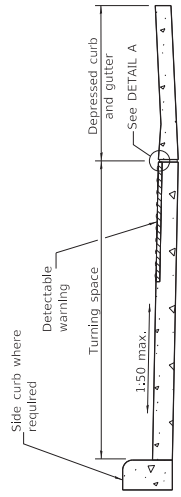

SECTION B-B

Side curb where required

Turning space
 5'x5' (1.52x1.52 m)
 typical, 4'x4'
 (1.22x1.22 m) min.

Crosswalk
 marking (typ.)

Depressed curb
 and gutter

Clear space
 4'x4' (1.22x1.22 m)
 min.

1:50 max.

Detectable
 warning

1:50 max.

Edge of
 gutter

Face of
 roadway

CORNER PARALLEL CURB RAMP

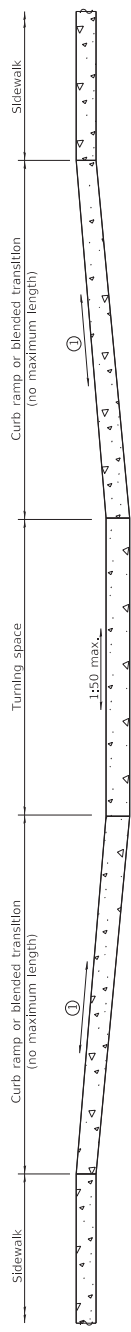

SECTION A-A

① The running slope of a curb ramp shall be 1:20 min, and 1:12 max. The running slope of a blended transition shall be 1:20 max.

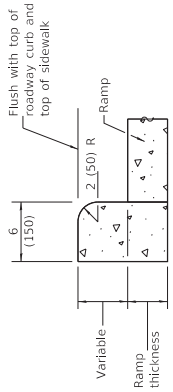

SIDE CURB DETAIL

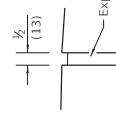

DETAIL A

GENERAL NOTES

All slope ratios are expressed as units of vertical displacement to units of horizontal displacement (V:H).

Where the turning space is constrained on a side opposite a ramp, the minimum length of the turning space in the direction of the ramp-on shall be 5' (1.52 m).

Where 1:50 maximum slope is shown, 1:64 is preferred.

Detectable warnings are shown in their ideal locations but the following placement tolerances are allowed.

Side Border - Detectable warnings should extend the full width of the walking surface (excluding flared slides) but a border along each side up to 2 in. (50 mm) in width is allowed.

Curb Set-Back - Detectable warnings located at the back of curb should closely align with the curb but a gap up to 6 in. (150 mm) behind the curb is allowed.

See Standard 606001 for details of depressed curb adjacent to curb ramp.

All dimensions are in inches (millimeters) unless otherwise shown.

DATE	REVISIONS
1-1-19	Removed upper landing, added blended transition and detectable warning tolerances.
1-1-17	Revised sidewalk width to include 24 (610) buffer behind curb.

CORNER PARALLEL CURB RAMPS FOR SIDEWALKS

STANDARD 424011-04

Illinois Department of Transportation

PASSED: *[Signature]* January 1, 2019
 ENGINEER OF POLICY AND PROCEDURES
 APPROVED: *[Signature]* January 1, 2019
 ENGINEER OF DESIGN AND ENVIRONMENT

ISSUED 1-1-12

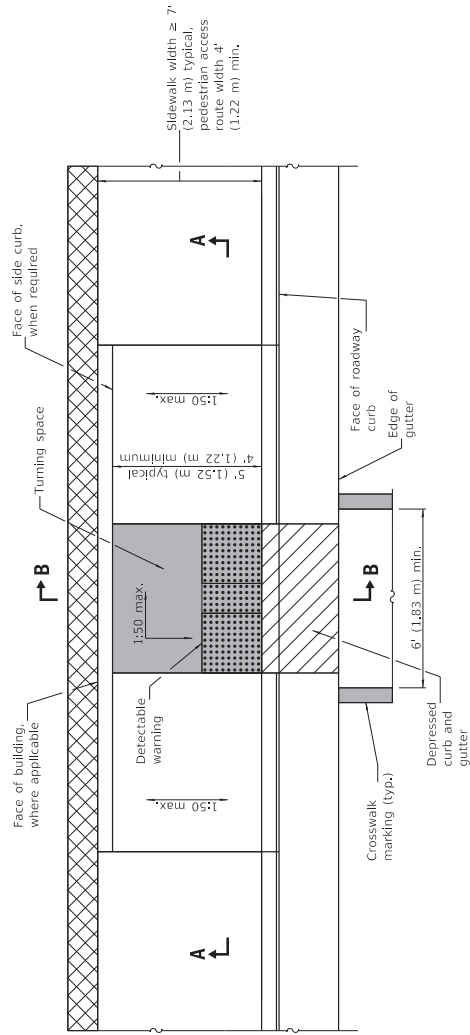

PARALLEL MID-BLOCK CURB RAMP

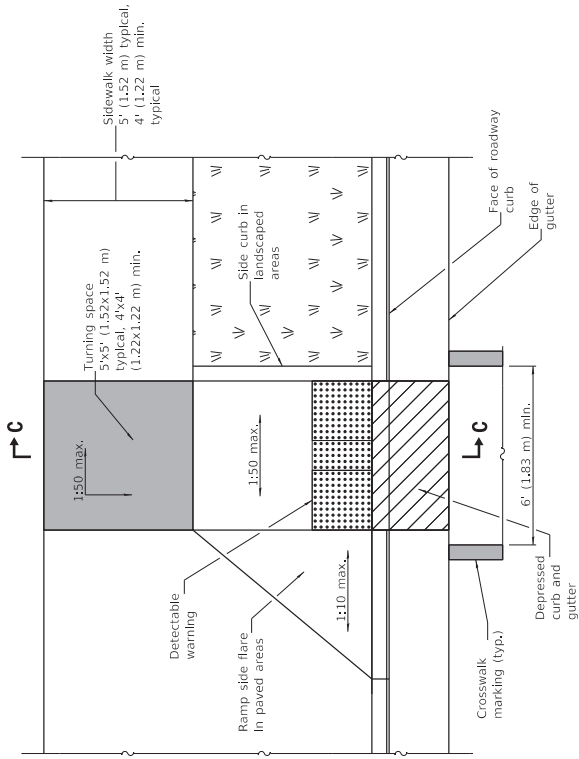

PERPENDICULAR MID-BLOCK CURB RAMP

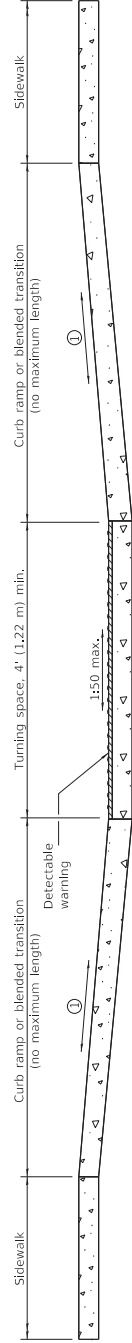

SECTION A-A

① The running slope of a curb ramp shall be 1:20 min. and 1:12 max. The running slope of a blended transition shall be 1:20 max.

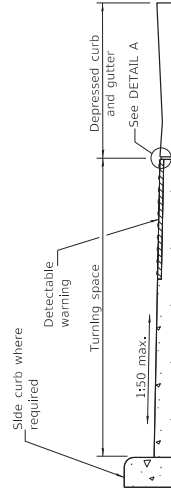

SECTION B-B

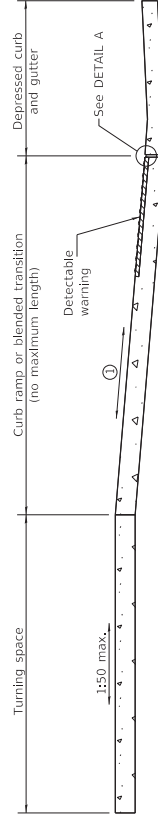

SECTION C-C

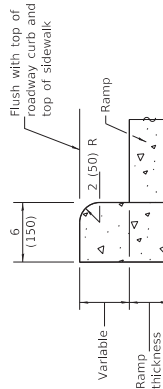

SIDE CURB DETAIL

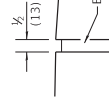

DETAIL A

GENERAL NOTES

All slope ratios are expressed as units of vertical displacement to units of horizontal displacement (V:H).

Where the turning space is constrained on a side opposite a ramp, the minimum length of the turning space in the direction of the ramp-run shall be 5' (1.52 m).

Where 1:50 maximum slope is shown, 1:64 is preferred.

Detectable warnings are shown in their ideal locations but the following placement tolerances are allowed.

Side Border - Detectable warnings should extend the full width of the walking surface (excluding flared slides) but a border along each side up to 2 in. (50 mm) in width is allowed.

Curb Set-Back - Detectable warnings located at the back of curb should closely align with the curb but a gap up to 6 in. (150 mm) behind the curb is allowed.

See Standard 606001 for details of depressed curb adjacent to curb ramp.

All dimensions are in inches (millimeters) unless otherwise shown.

DATE	REVISIONS
1-1-19	Removed upper landing, added blended transitions and detectable warning tolerances.
1-1-18	Omitted diagonal slope at turning spaces and upper landings.

MID-BLOCK CURB RAMPS FOR SIDEWALKS

STANDARD 424016-05

PASSED January 1, 2019
 APPROVED January 1, 2019
 ENGINEER OF POLICY AND PROCEDURES
 ENGINEER OF DESIGN AND ENVIRONMENT

ISSUED 1-1-12

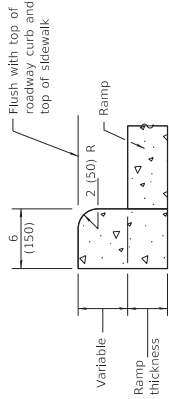
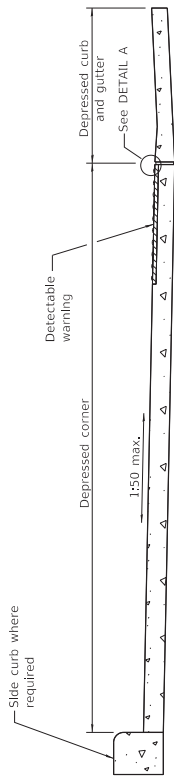
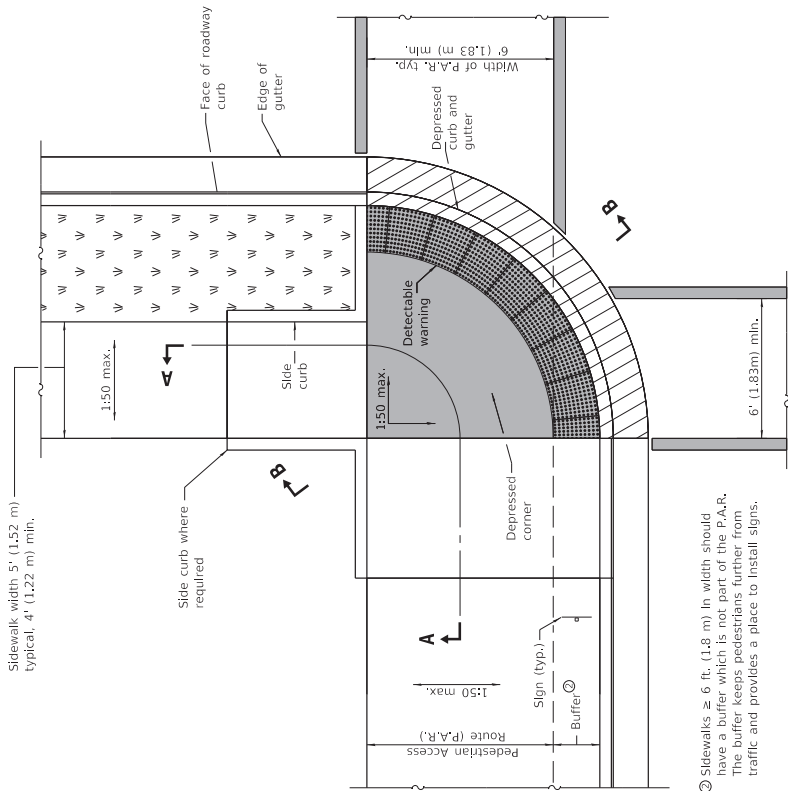

DETAIL A

GENERAL NOTES

This standard shall only be used for curb radii of 6 ft. (1.83 m) or greater.

All slope ratios are expressed as units of vertical displacement to units of horizontal displacement (V:H).

Where 1:50 maximum slope is shown, 1:64 is preferred.

Detectable warnings are shown in their ideal tolerances but the following placement tolerances are allowed.

Side Border - Detectable warnings should extend the full width of the walking surface (excluding flared sides) but a border along each side up to 2 in. (50 mm) in. width is allowed.

Curb Set-Back - Detectable warnings located at the back of curb should closely align with the curb but a gap up to 6 in. (150 mm) behind the curb is allowed.

See Standard 606001 for details of depressed curb adjacent to curb ramp.

All dimensions are in inches (millimeters) unless otherwise shown.

DEPRESSED CORNER FOR SIDEWALKS

STANDARD 424021-06

DATE	REVISIONS
1-1-21	Added crosswalk striping and a "buffer" for wide sidewalks.
1-1-19	Removed upper landings; added blended transition and detectable warning tolerances.

DEPRESSED CORNER



Illinois Department of Transportation
 PASSED: [Signature] January 1, 2021
 ENGINEER OF POLICY AND PROCEDURES
 APPROVED: [Signature] January 1, 2021
 ENGINEER OF DESIGN AND ENVIRONMENT

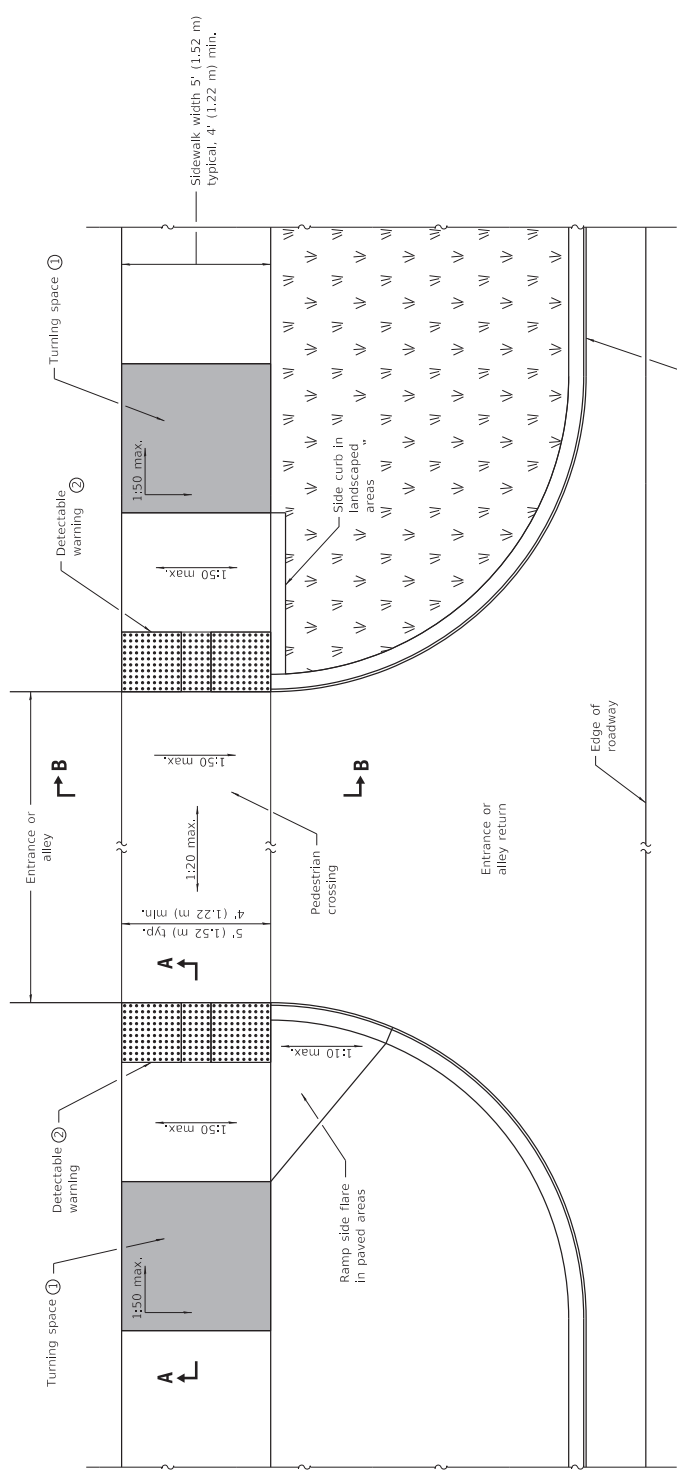

- ② Detectable warning shall only be installed at entrances/alleys with permanent traffic control devices (i.e. stop signs, signals).
- ③ Where possible, maintain the grade of the sidewalk across the entrance/alley to avoid the need for ramps and turning spaces.

ENTRANCE / ALLEY PEDESTRIAN CROSSING

GENERAL NOTES
All slope ratios are expressed as units of vertical displacement to units of horizontal displacement (V:H).

Where 1:50 maximum slope is shown, 1:64 is preferred.

Detectable warnings are shown in their ideal locations but the following placement tolerances are allowed.

Side Border - Detectable warnings should extend the full width of the walking surface (excluding flared sides) but a border along each side up to 2 in. (50 mm) in width is allowed.

Curb Setback - Detectable warnings located at the back of curb should closely align with the curb but a gap up to 6 in. (150 mm) behind the curb is allowed.

All dimensions are in inches (millimeters) unless otherwise shown.

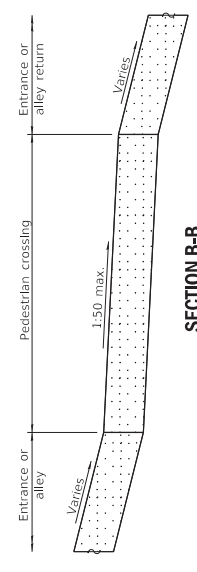

SECTION B-B

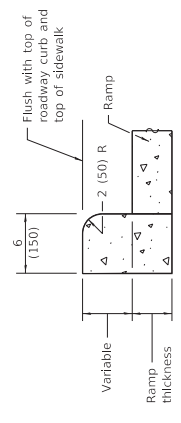

SIDE CURB DETAIL

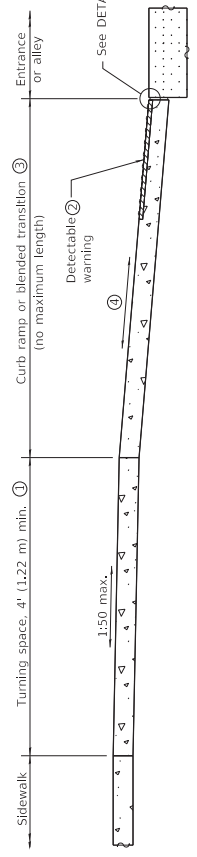

SECTION A-A

① Turning space not required for blended transitions.

④ The running slope of a curb ramp shall be 1:20 min and 1:12 max. The running slope of a blended transition shall be 1:20 max.

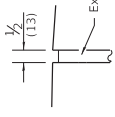

DETAIL A

DATE	REVISIONS
1-1-19	Added blended transitions and placement tolerances for detectable warnings.
1-1-18	Omitted diagonal slope at upper landings.

Illinois Department of Transportation
 PASSED: [Signature] January 1, 2019
 ENGINEER OF POLICY AND PROCEDURES
 APPROVED: [Signature] January 1, 2019
 ENGINEER OF DESIGN AND ENVIRONMENT

ENTRANCE / ALLEY PEDESTRIAN CROSSINGS

STANDARD 424026-03

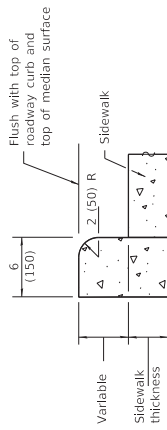

SIDE CURB DETAIL

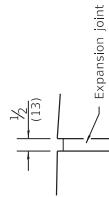

DETAIL A

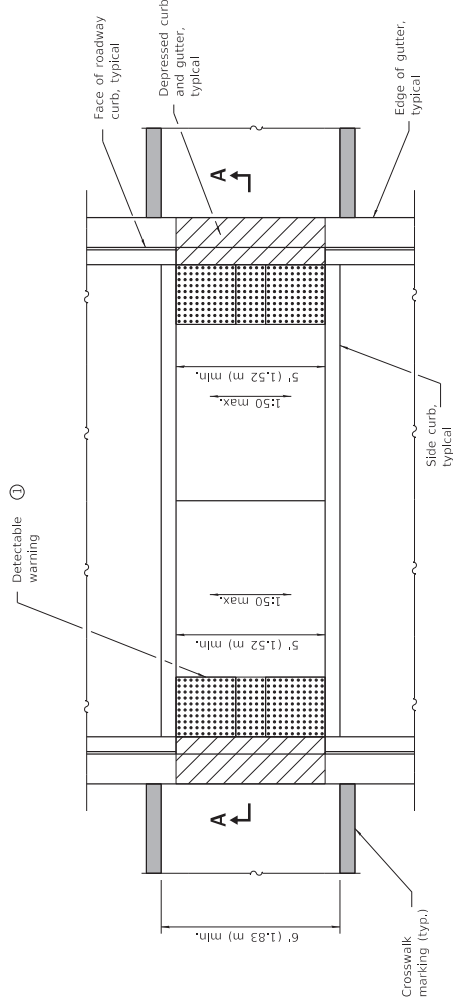

MEDIAN PEDESTRIAN CROSSING

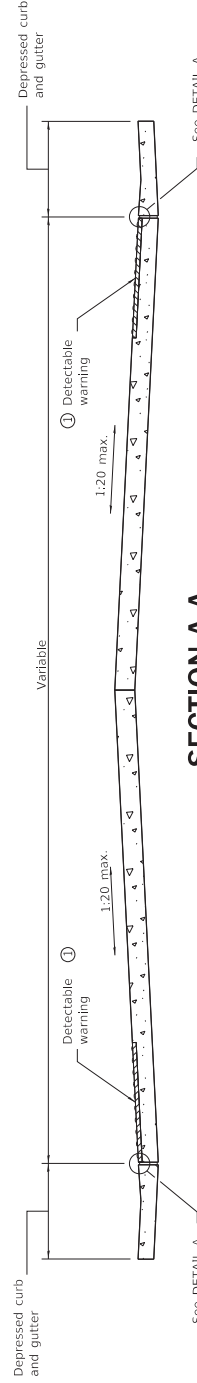

SECTION A-A

① Omit detectable warnings when distance between back of curbs is less than 6' (1.83 m).

GENERAL NOTES

All slope ratios are expressed as units of vertical displacement to units of horizontal displacement (V:H).

Where 1:50 maximum slope is shown, 1:64 is preferred.

Detectable warnings are shown in their ideal locations but the following placement tolerances are allowed.

Side Border - Detectable warnings should extend the full width of the walking surface (excluding flared sides) but a border along each side up to 2 in. (50 mm) in width is allowed.

Curb Set-Back - Detectable warnings located at the back of curb should closely align with the curb but a gap up to 6 in. (150 mm) behind the curb is allowed.

See Standard 606001 for details of depressed curb adjacent to curb ramp.

All dimensions are in inches (millimeters) unless otherwise shown.

Illinois Department of Transportation PASSED ENGINEER OF POLICY AND PROCEDURES APPROVED ENGINEER OF DESIGN AND ENVIRONMENT	JANUARY 1, 2019
	ISSUED 1-1-12 JANUARY 1, 2019

DATE	REVISIONS
1-1-19	Added placement tolerances for detectable warnings.
1-1-12	Widened crosswalk to 6' (1.83 m) min. inside dimension.
	Revised General Notes.

MEDIAN PEDESTRIAN CROSSINGS

STANDARD 424031-02

CLASS C

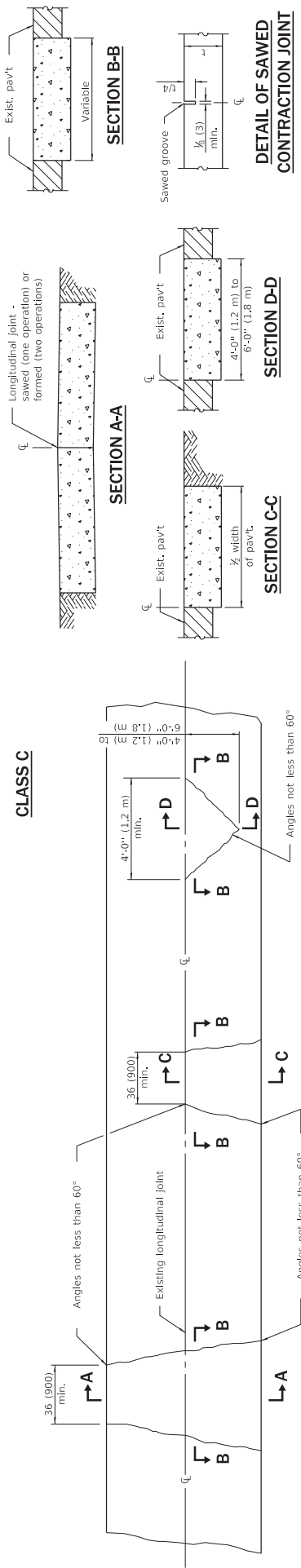

Note:
Longitudinal joints shall be as detailed on Standard 420001, except tie bars are not required for patches 20'-0" (6.0 m) or less in length.

CLASS D

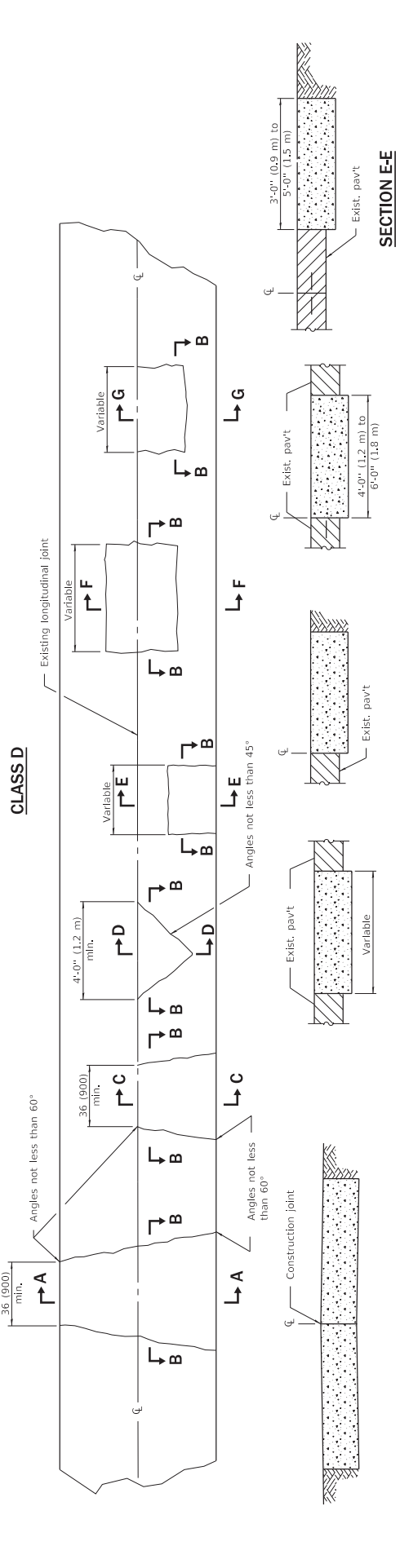

GENERAL NOTES
Existing tie bars shall be either cut or removed. Marginal bars shall be cut.
All dimensions are in inches (millimeters) unless otherwise shown.

SECTION A-A
(Built in two operations)

SECTION B-B

SECTION C-C

SECTION D-D

SECTION E-E

SECTION F-F
(Built in two operations)

SECTION G-G

Illinois Department of Transportation PASSED January 1, 2008 ENGINEER OF POLICY AND PROCEDURES APPROVED January 1, 2008 ENGINEER OF DESIGN AND ENVIRONMENT	ISSUED 1-1-07
	[Signature] [Signature]

DATE	REVISIONS
1-1-08	Switched units to English (metric).
1-1-07	Revised Note for Class C patches.

CLASS C and D PATCHES

STANDARD 442201-03

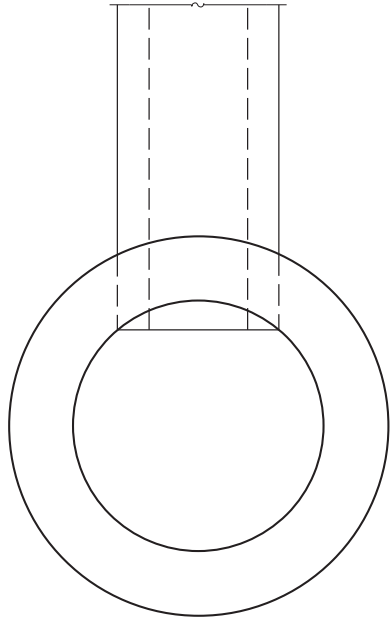

PLAN

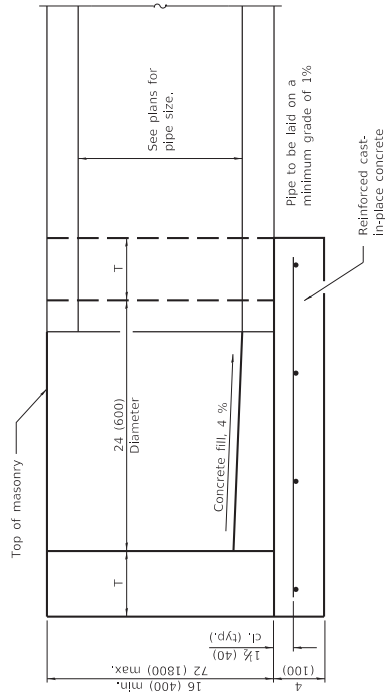

ELEVATION

ALTERNATE MATERIALS FOR WALLS	T
BRICK MASONRY	8 (200)
CAST-IN-PLACE CONCRETE	6 (150)
CONCRETE MASONRY UNIT	5 (125)
PRECAST REINFORCED CONCRETE SECTION	3 (75)

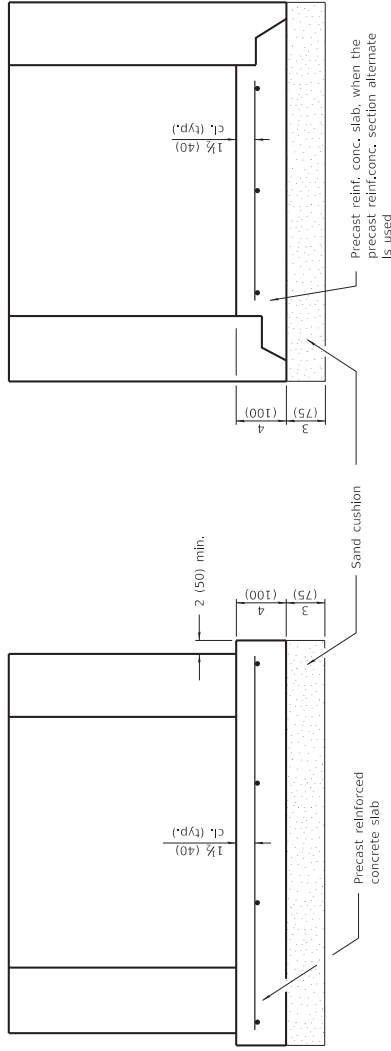

ALTERNATE METHODS

GENERAL NOTES

Bottom slabs shall be reinforced with a minimum of 0.24 sq. in./ft. (510 sq. mm/m) in both directions with a maximum spacing of 10 (250).

Bottom slabs may be connected to the riser as determined by the fabricator; however, only a single row of reinforcement around the perimeter may be utilized.

All dimensions are in inches (millimeters) unless otherwise shown.

DATE	REVISIONS
1-1-14	Increased height to 72 (1800) maximum.
1-1-11	Detailed reinf. in slabs. Added max. limit to height.
	Added general notes.

INLET - TYPE A

STANDARD 602301-04

Illinois Department of Transportation
 PASSED January 1, 2014
 Michael Bond
 ENGINEER OF POLICY AND PROCEDURES
 APPROVED January 1, 2014
 ENGINEER OF DESIGN AND ENVIRONMENT

6 Gussets shown
10 permitted

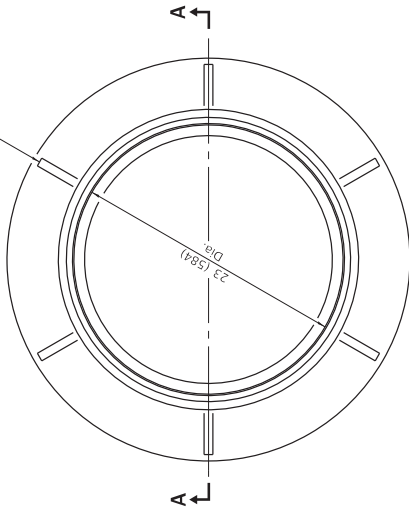

CAST FRAME

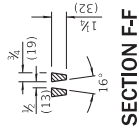
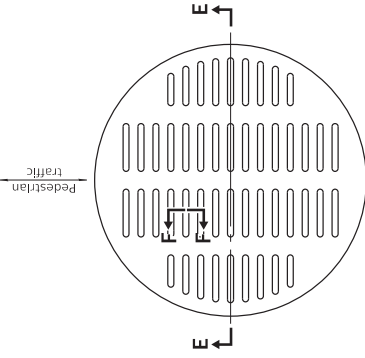

SECTION F-F

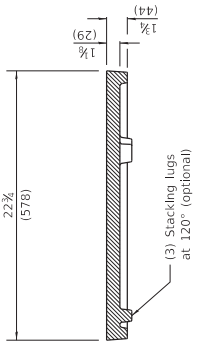
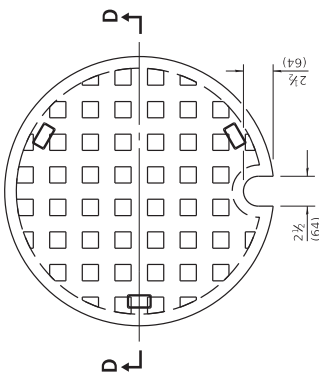

SECTION D-D

CAST CLOSED LID
Gray Iron Lid

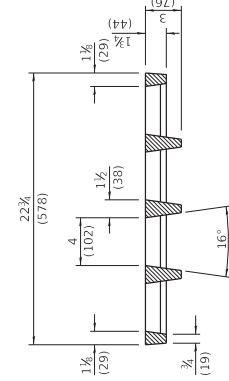

SECTION E-E

**ADA COMPLIANT
CAST OPEN LID**

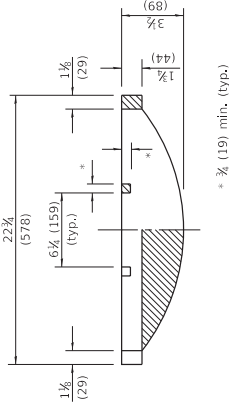

SECTION B-B

CAST OPEN LID

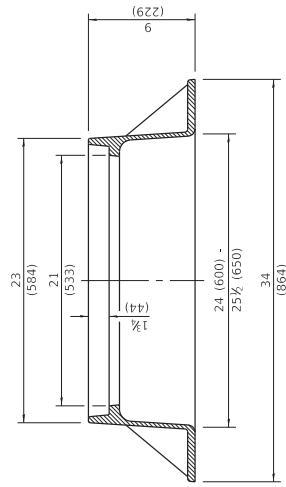

SECTION A-A
Gray Iron

All dimensions are in inches (millimeters) unless otherwise shown.

DATE	REVISIONS
1-1-20	Revised dimension in Section B-B of cast open lid.
1-1-15	Revised dimensioning of frame. Added ADA compliant open lid.
1-1-09	Switched units to English (metric).

**FRAME AND LIDS
TYPE 1**

STANDARD 604001-05

Illinois Department of Transportation
ISSUED 1-1-07

PASSED
January 1, 2020
ENGINEER OF POLICY AND PROCEDURES

APPROVED
January 1, 2020
ENGINEER OF DESIGN AND ENVIRONMENT

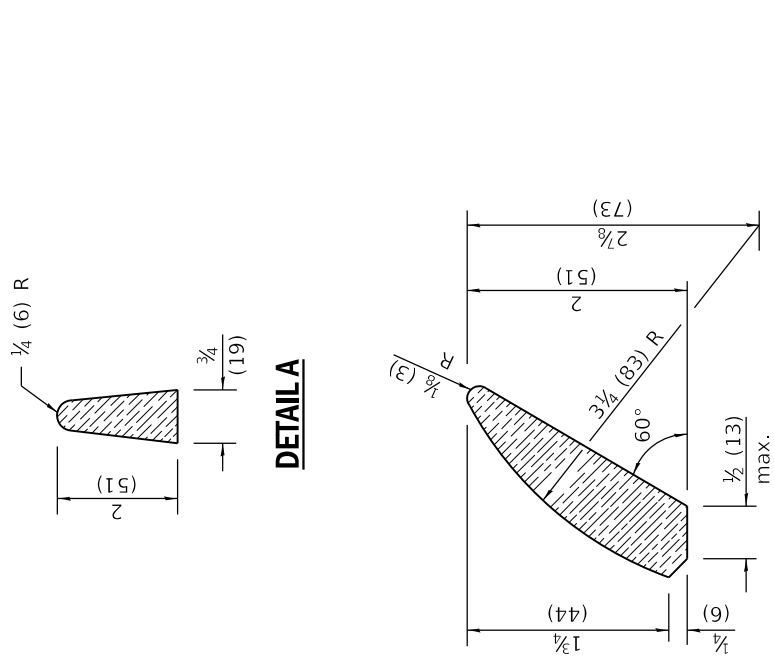

DETAIL A

DETAIL B

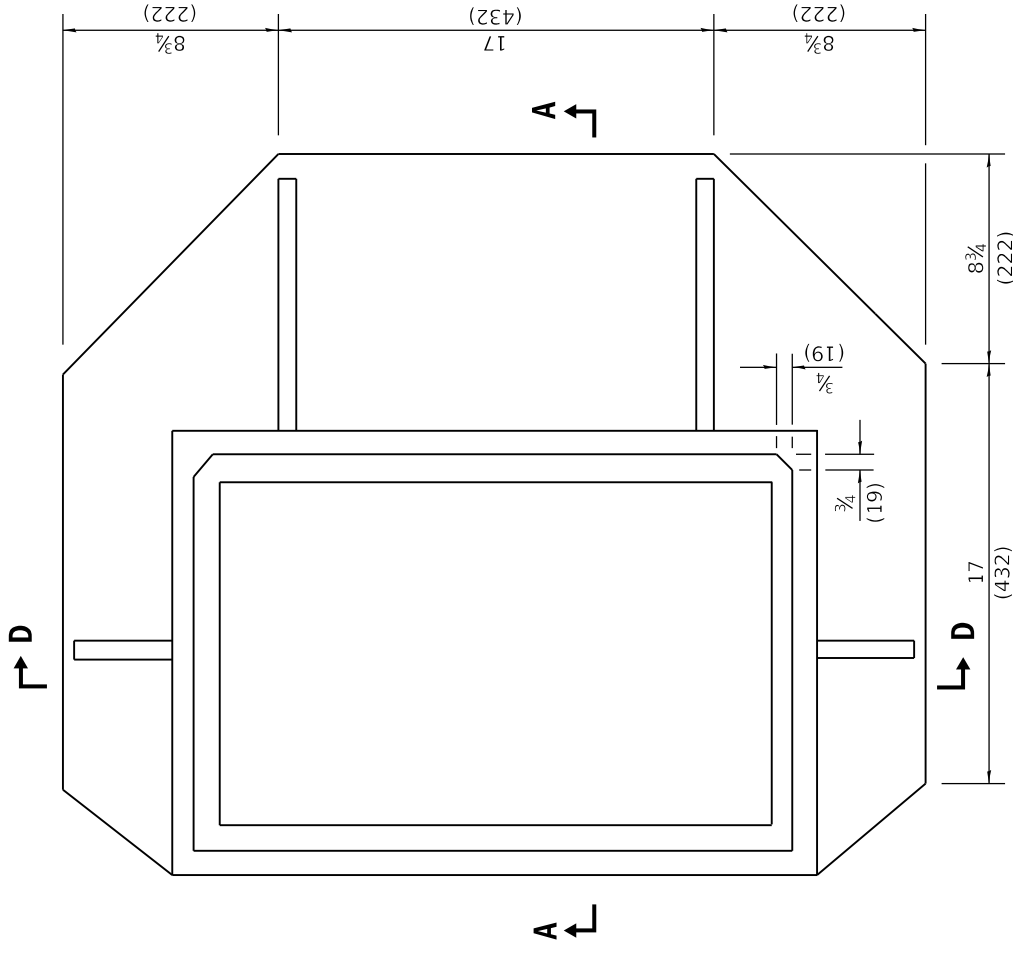

PLAN - FRAME

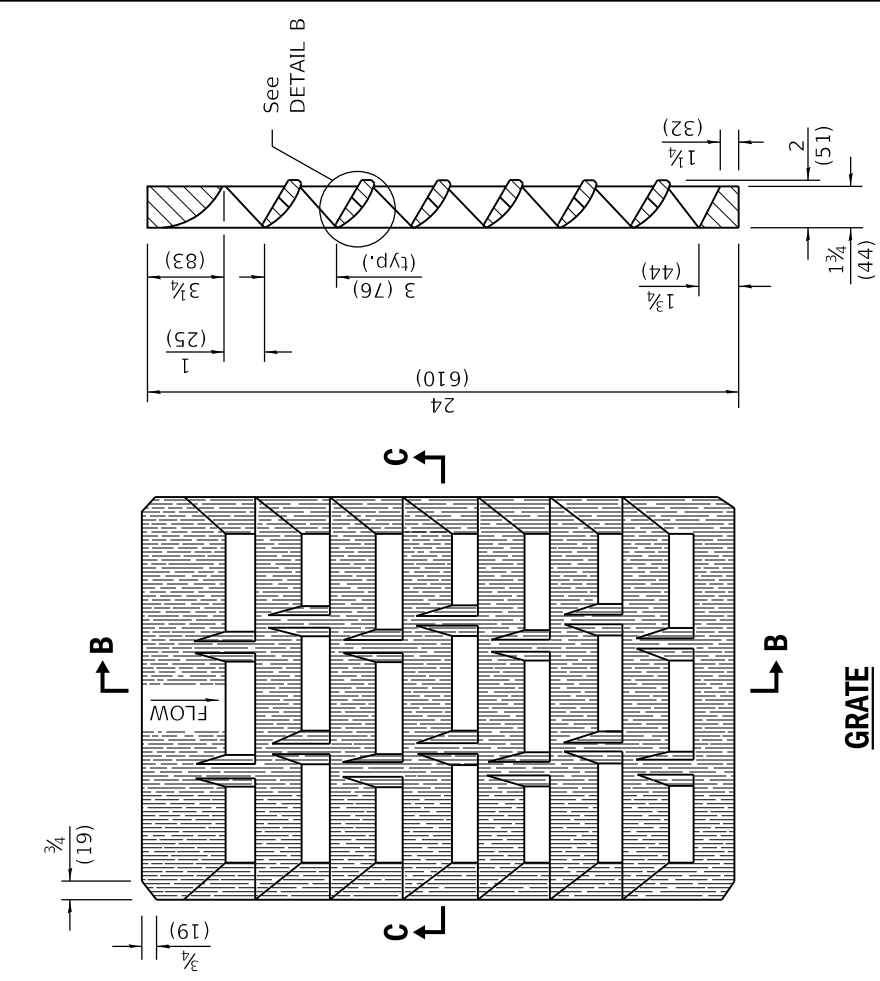

GRATE

SECTION B-B

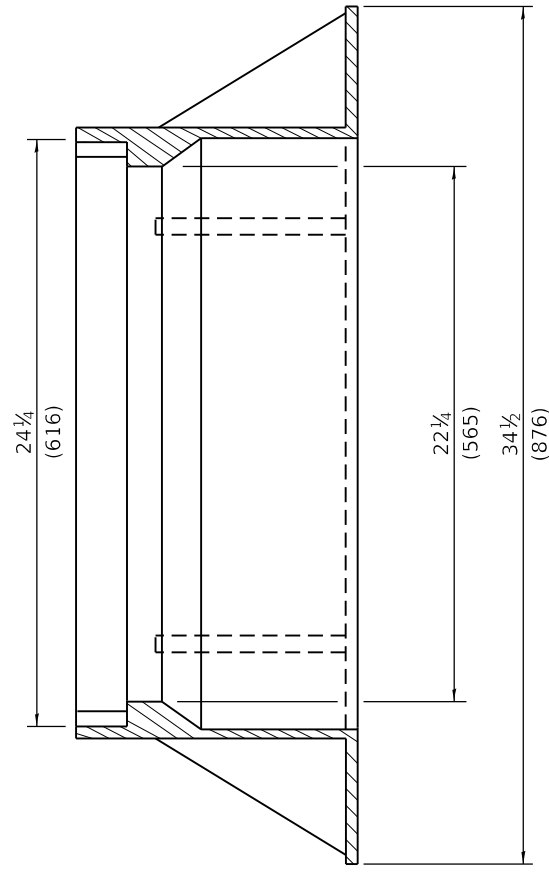

SECTION D-D

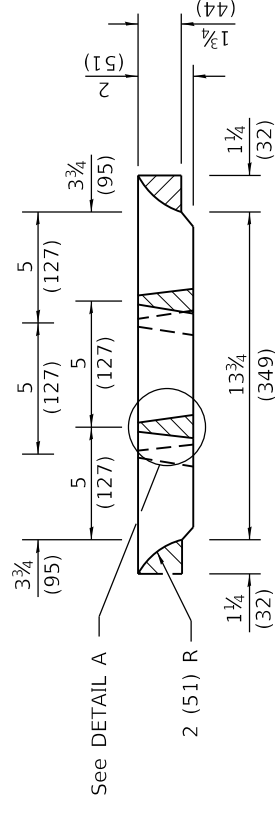

SECTION C-C

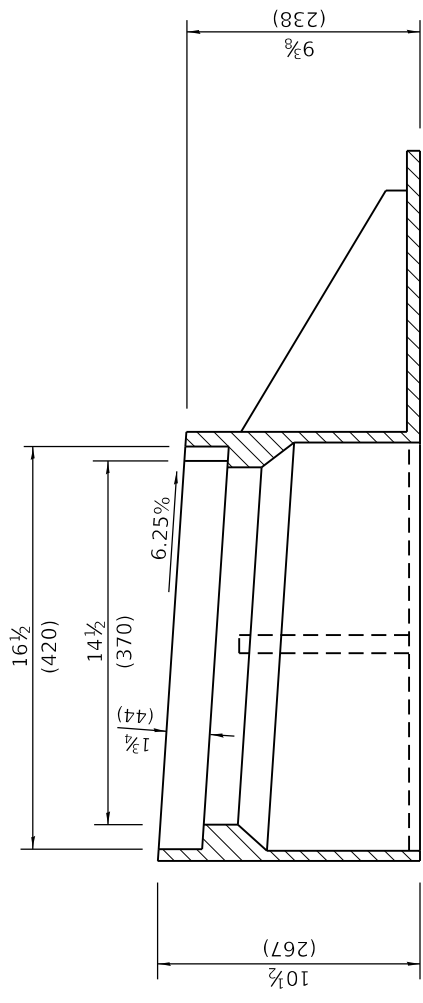

SECTION A-A

All dimensions are in inches (millimeters) unless otherwise shown.

Illinois Department of Transportation
 PASSED January 1, 2022
Michael Brand
 ENGINEER OF POLICY AND PROCEDURES
 APPROVED January 1, 2022
Seth Cole
 ENGINEER OF DESIGN AND ENVIRONMENT

ISSUED 1-1-97

DATE	REVISIONS
1-1-22	Removed slots in frame which held the "safety bars".
1-1-21	Removed "safety bars" from frame.

**FRAME AND GRATE
 TYPE 23**

STANDARD 604086-05

Doweled contraction joint
(Placed in prolongation with pavement joints)
construction option:

1. Form with 1/8 (3) thick steel template
2 (50) deep, and seal.
2. Saw at 4 to 24 hours, and seal.

Short radius curve
(Such as entrances,
side streets and
ramp returns).

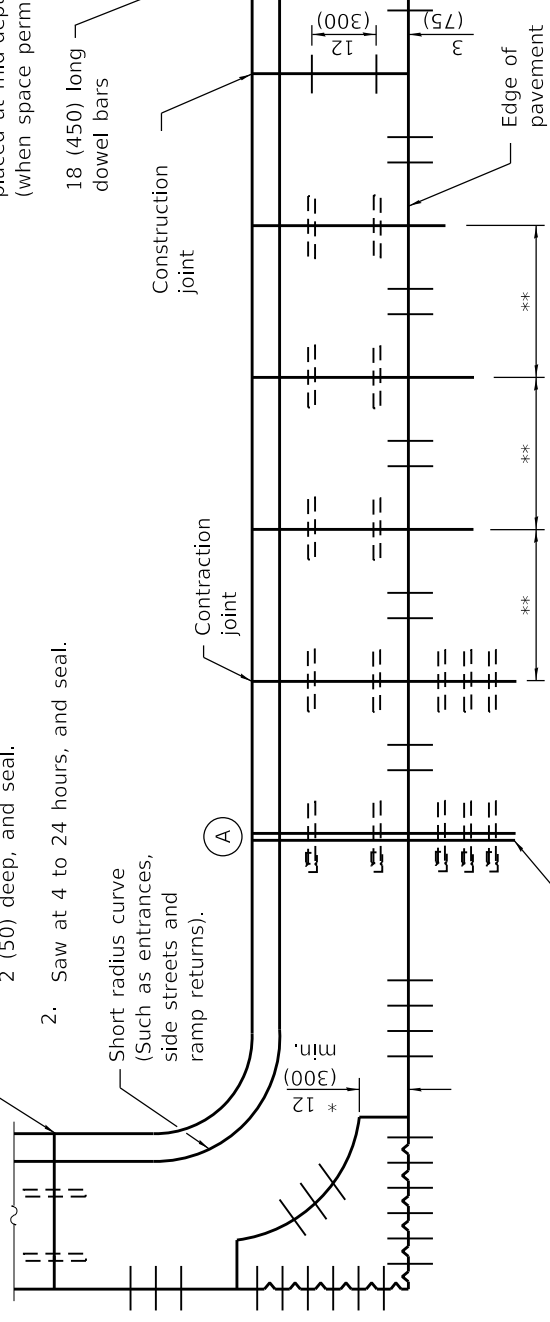

Pavement expansion joint with (or without) dowels

PLAN

ADJACENT TO PCC PAVEMENT OR PCC BASE COURSE

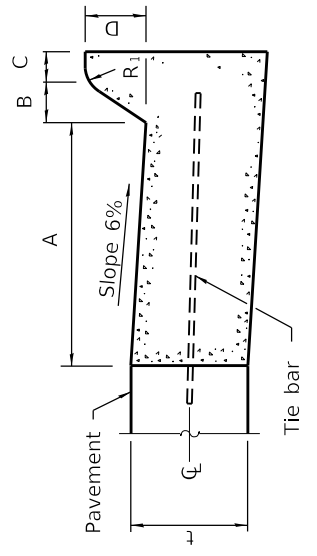
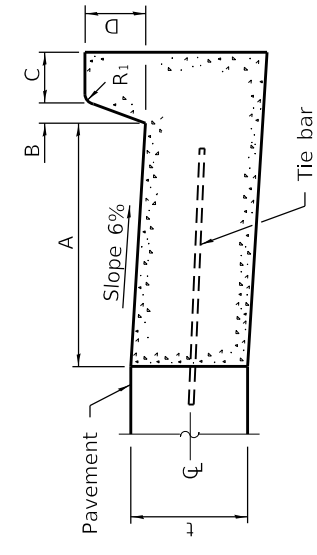

BARRIER CURB

TYPE	A	B	C	D	R ₁
B-6.06 *	6	1	6	6	1
(B-15.15)	(150)	(25)	(150)	(150)	(25)
B-6.12	12	1	6	6	1
(B-15.3)	(300)	(25)	(150)	(150)	(25)
B-6.18	18	1	6	6	1
(B-15.45)	(450)	(25)	(150)	(150)	(25)
B-6.24	24	1	6	6	1
(B-15.60)	(600)	(25)	(150)	(150)	(25)
B-9.12	12	2	5	9	1
(B-22.30)	(300)	(50)	(125)	(225)	(25)
B-9.18	18	2	5	9	1
(B-22.45)	(450)	(50)	(125)	(225)	(25)
B-9.24	24	2	5	9	1
(B-22.60)	(600)	(50)	(125)	(225)	(25)

* For corner islands only.

MOUNTABLE CURB

TYPE	A	B	C	D	R ₁	R ₂
M-2.06	6	2	4	2	3	2
(M-5.15)	(150)	(50)	(100)	(50)	(75)	(50)
M-2.12	12	2	4	2	3	2
(M-5.30)	(300)	(50)	(100)	(50)	(75)	(50)
M-4.06	6	4	3	4	3	NA
(M-10.15)	(150)	(100)	(75)	(100)	(75)	NA
M-4.12	12	4	3	4	3	NA
(M-10.30)	(300)	(100)	(75)	(100)	(75)	NA
M-4.18	18	4	3	4	3	NA
(M-10.45)	(450)	(100)	(75)	(100)	(75)	NA
M-4.24	24	4	3	4	3	NA
(M-10.60)	(600)	(100)	(75)	(100)	(75)	NA
M-6.06	6	6	2	6	2	NA
(M-15.15)	(150)	(150)	(50)	(150)	(50)	NA
M-6.12	12	6	2	6	2	NA
(M-15.30)	(300)	(150)	(50)	(150)	(50)	NA
M-6.18	18	6	2	6	2	NA
(M-15.45)	(450)	(150)	(50)	(150)	(50)	NA
M-6.24	24	6	2	6	2	NA
(M-15.60)	(600)	(150)	(50)	(150)	(50)	NA

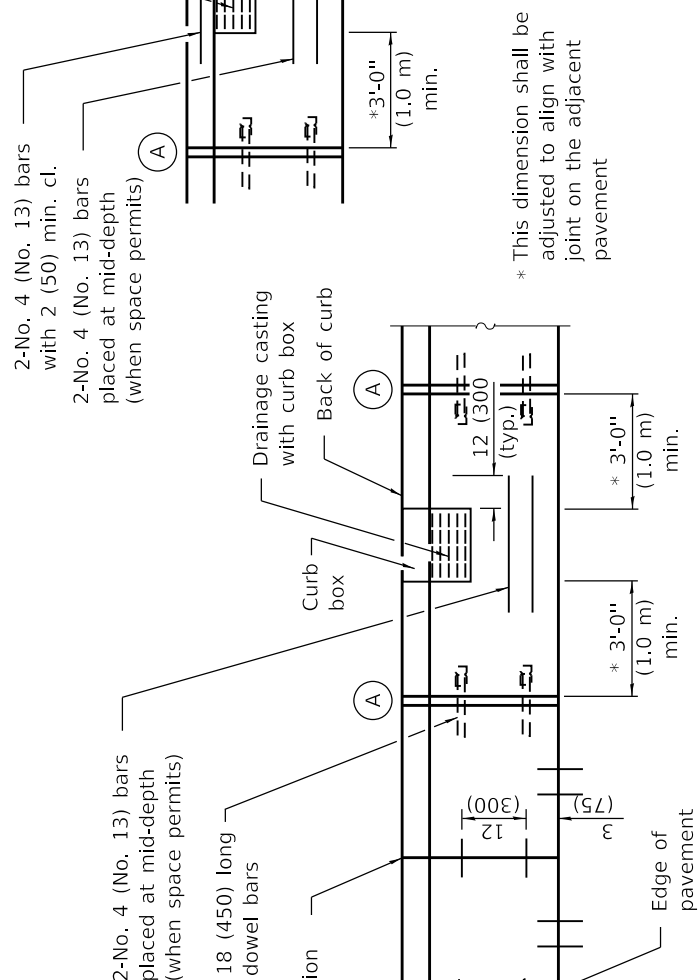

* This dimension shall be adjusted to align with joint on the adjacent pavement

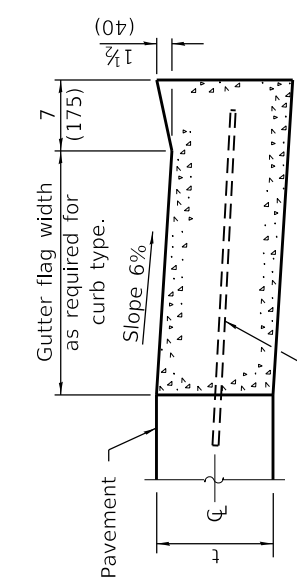

DEPRESSED CURB (TYPICAL)

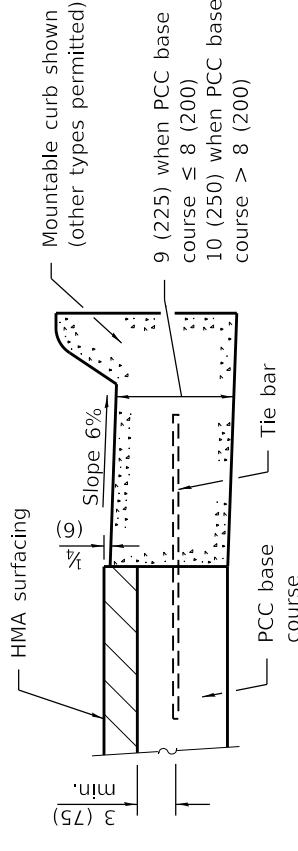

ADJACENT TO PCC BASE COURSE WITH HMA SURFACING

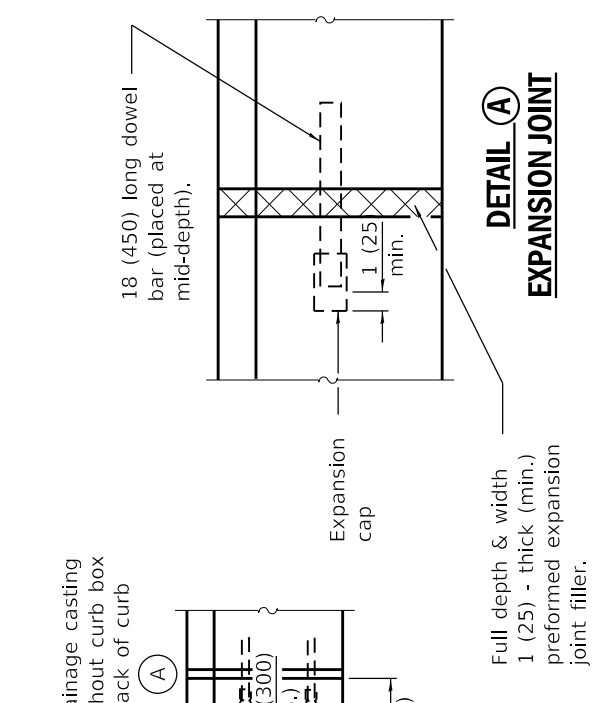
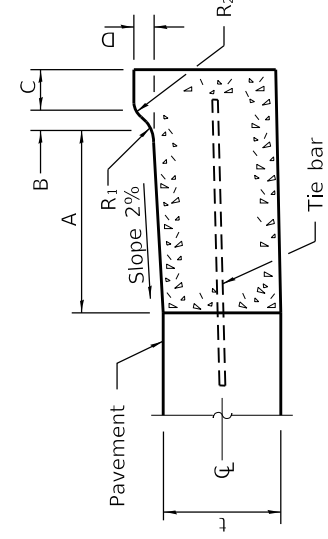

DETAIL (A) EXPANSION JOINT

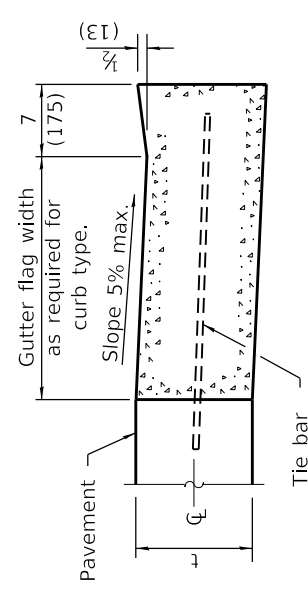

DEPRESSED CURB ADJACENT TO CURB RAMP ACCESSIBLE TO THE DISABLED

GENERAL NOTES

The bottom slope of combination curb and gutter constructed adjacent to pcc pavement shall be the same slope as the subbase or 6% when subbase is omitted.

t = Thickness of pavement.

Longitudinal joint tie bars shall be No. 6 (No. 19) at 36 (900) centers in accordance with details for longitudinal construction joint shown on Standard 420001.

A minimum clearance of 2 (50) between the end of the tie bar and the back of the curb shall be maintained.

The dowel bars shown in contraction joints will only be required for monolithic construction.

See Standard 606301 for details of corner islands.

All dimensions are in inches (millimeters) unless otherwise shown.

CONCRETE CURB TYPE B AND COMBINATION CONCRETE CURB AND GUTTER	
DATE	REVISIONS
1-1-22	Revised contraction joint spacing adjacent to pcc pavement.
1-1-18	Revised General Note for tie bar spacing to 36 (900) cts.

M-2.06 (M-5.15) and M-2.12 (M-5.30)

STANDARD 606001-08

ISSUED 1-1-97

PASSED January 1, 2022
 Michael B. Bond
 ENGINEER OF POLICY AND PROCEDURES

APPROVED January 1, 2022
 Soldo
 ENGINEER OF DESIGN AND ENVIRONMENT

Illinois Department of Transportation

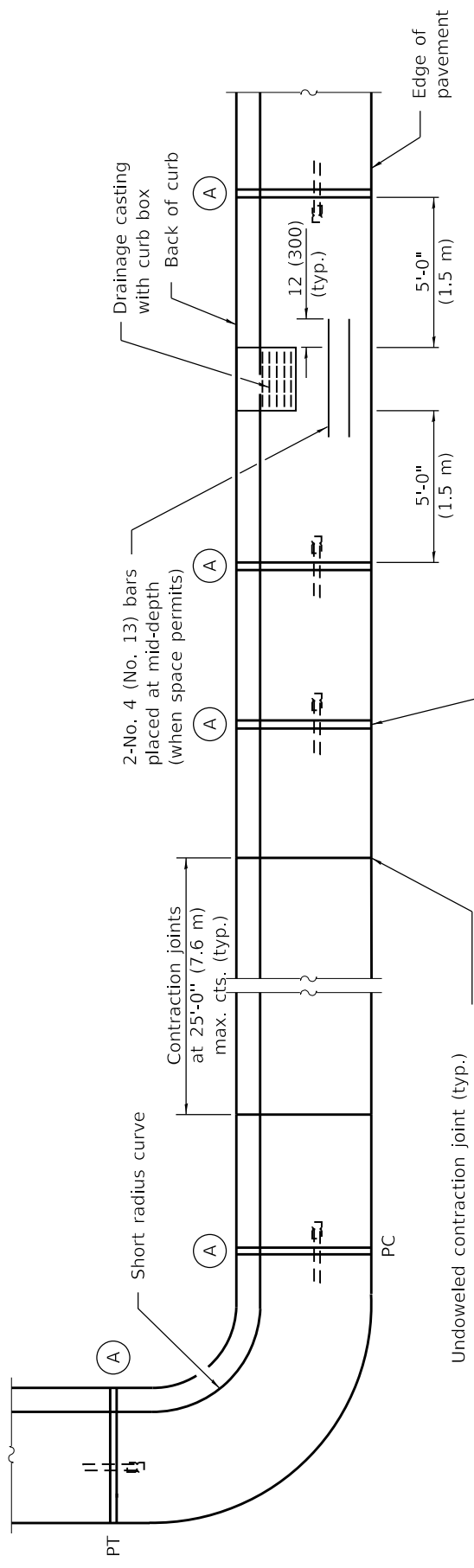

Undoweled contraction joint (typ.) construction options:

1. Form with $\frac{1}{8}$ (3) thick steel template
2 (50) deep, and seal.
2. Saw 2 (50) deep at 4 to 24 hours, and seal.
3. Insert $\frac{3}{4}$ (20) thick preformed joint filler full depth and width.

Construction joint
2-No. 4 (No. 13) bars with 2 (50) min. cl.

2-No. 4 (No. 13) bars placed at mid-depth (when space permits)

Drainage casting with curb box
Back of curb

Drainage casting without curb box
Back of curb

PLAN

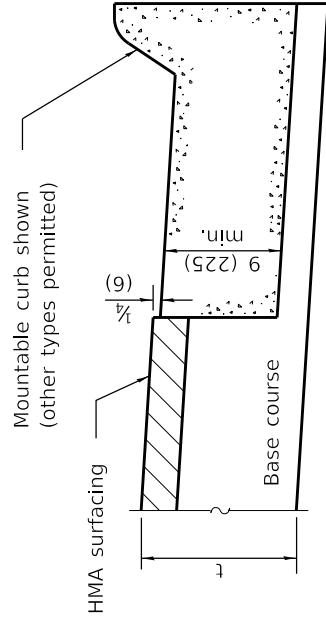

ON DISTURBED SUBGRADE

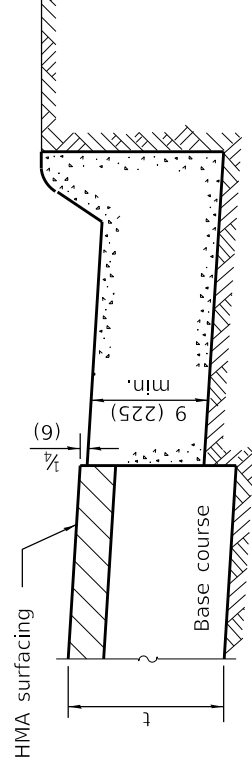

ON UNDISTURBED SUBGRADE

Illinois Department of Transportation

PASSED January 1, 2022
Michael Beard
 ENGINEER OF POLICY AND PROCEDURES

APPROVED January 1, 2022
Sally Cole
 ENGINEER OF DESIGN AND ENVIRONMENT

ISSUED 1-1-97

ADJACENT TO FLEXIBLE PAVEMENT

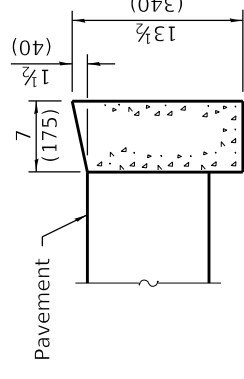

DEPRESSED CURB

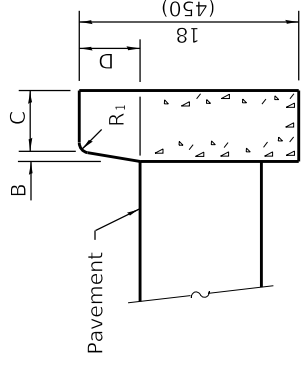

BARRIER CURB

ADJACENT TO FLEXIBLE PAVEMENT

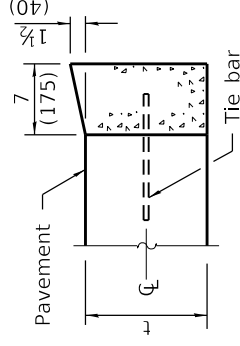

DEPRESSED CURB

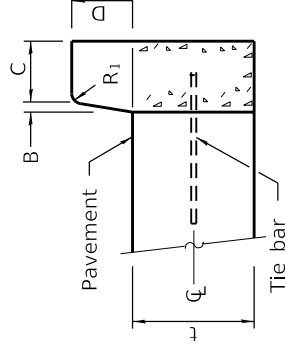

BARRIER CURB

ADJACENT TO PCC PAVEMENT OR PCC BASE COURSE

CONCRETE CURB TYPE B

**CONCRETE CURB TYPE B
AND COMBINATION
CONCRETE CURB AND GUTTER**

(Sheet 2 of 2)

STANDARD 606001-08

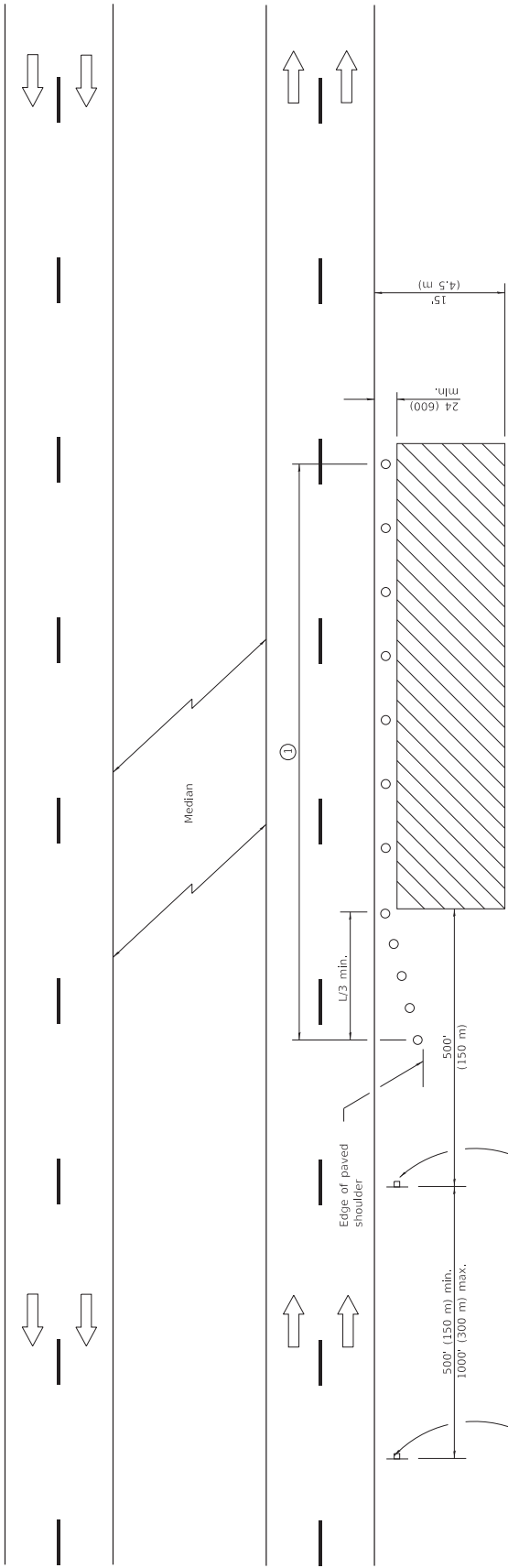

For contract construction projects



W20-1103(0)-48

For maintenance and utility projects



W20-110-48

W21-110-48

TYPICAL APPLICATIONS

- Utility operations
- Culvert extensions
- Side slope changes
- Guardrail installation and maintenance
- Delineator installation
- Landscaping operations
- Shoulder repair
- Sign installation and maintenance

① When the work operation exceeds one hour, cones, drums or barricades shall be placed at 25' (8 m) centers for L/3 distance, and at 50' (15 m) centers through the remainder of the work area.

GENERAL NOTES

This Standard is used where any vehicles, equipment, workers or their activities will encroach in the area 15' (4.5 m) to 24' (600) from the edge of pavement.

Calculate L as follows:

SPEED LIMIT	English	FORMULAS (Metric)
	40 mph (70 km/h) or less:	$L = \frac{WS^2}{60}$
45 mph (80 km/h) or greater:	$L = \frac{WS^2}{150}$	$L = 0.65(W)(S)$

W = Width of offset in feet (meters).
 S = Normal posted speed mph (km/h).

All dimensions are in inches (millimeters) unless otherwise shown.

DATE	REVISIONS
4-1-16	Corrected typo in title.
1-1-14	Revised workers sign number to agree with current MUTCD.

SYMBOLS

- Work area
- Sign
- Cone, drum or barricade

OFF-RD OPERATIONS, MULTILANE, 15' (4.5 m) TO 24" (600 mm) FROM PAVEMENT EDGE

STANDARD 701101-05

Illinois Department of Transportation

PASSED April 1, 2016

APPROVED April 1, 2016

ENGINEER OF SAFETY ENGINEERING

ENGINEER OF DESIGN AND ENVIRONMENT

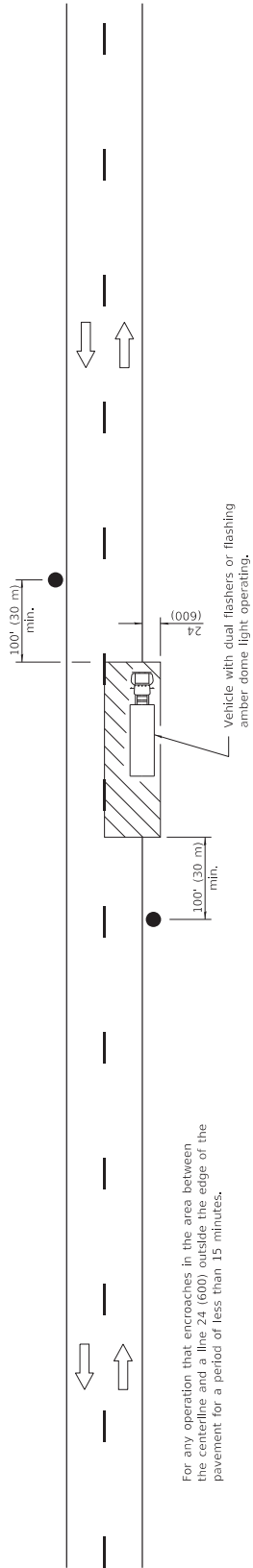

For any operation that encroaches in the area between the centerline and a line 24 (600) outside the edge of the pavement for a period of less than 15 minutes.

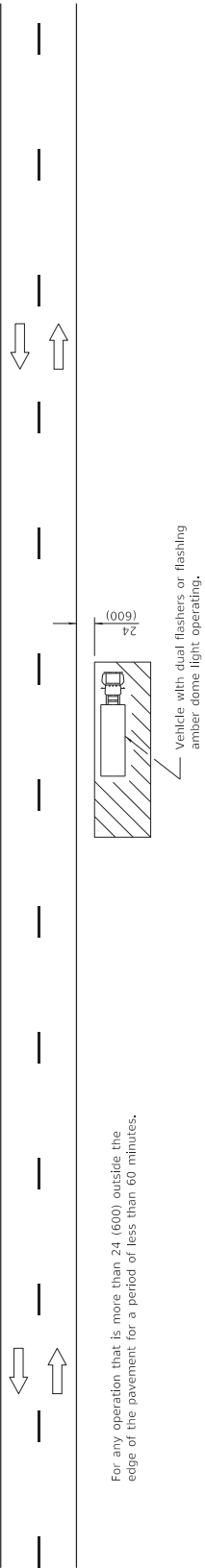

For any operation that is more than 24 (600) outside the edge of the pavement for a period of less than 60 minutes.

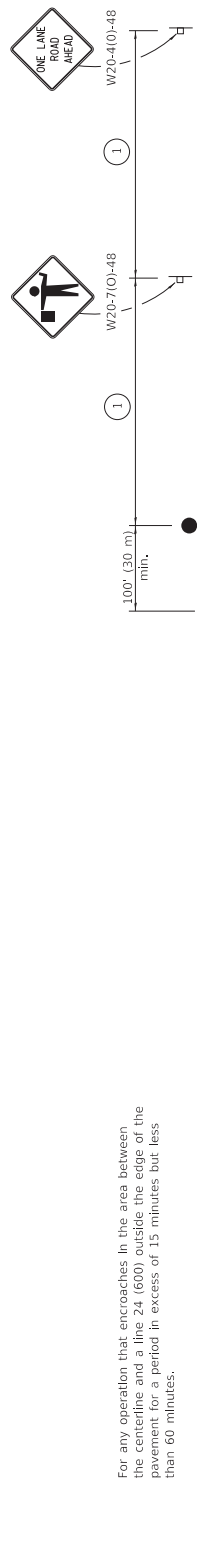

For any operation that encroaches in the area between the centerline and a line 24 (600) outside the edge of the pavement for a period in excess of 15 minutes but less than 60 minutes.

SIGN SPACING	
Posted Speed	Sign Spacing
55	500' (150 m)
50-45	350' (100 m)
<45	200' (60 m)

① = Refer to SIGN SPACING table for distances.

SYMBOLS

- Work area
- Sign on portable or permanent support
- Flagger with traffic control sign

TYPICAL APPLICATIONS

- Marking patches
- Field survey
- String line
- Utility operations
- Cleaning up debris on pavement

All dimensions are in inches (millimeters) unless otherwise shown.

LANE CLOSURE, 2L, 2W, SHORT TIME OPERATIONS

STANDARD 701301-04

DATE	REVISIONS
1-1-11	Revised flagger sign.
1-1-09	Switched units to English (metric).

Illinois Department of Transportation
 PASSED January 1, 2011
 ENGINEER OF SAFETY ENGINEERING
 APPROVED January 1, 2011
 ENGINEER OF DESIGN AND ENVIRONMENT

ISSUED 1-1-07

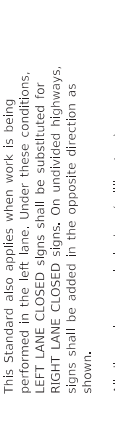
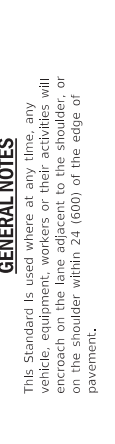
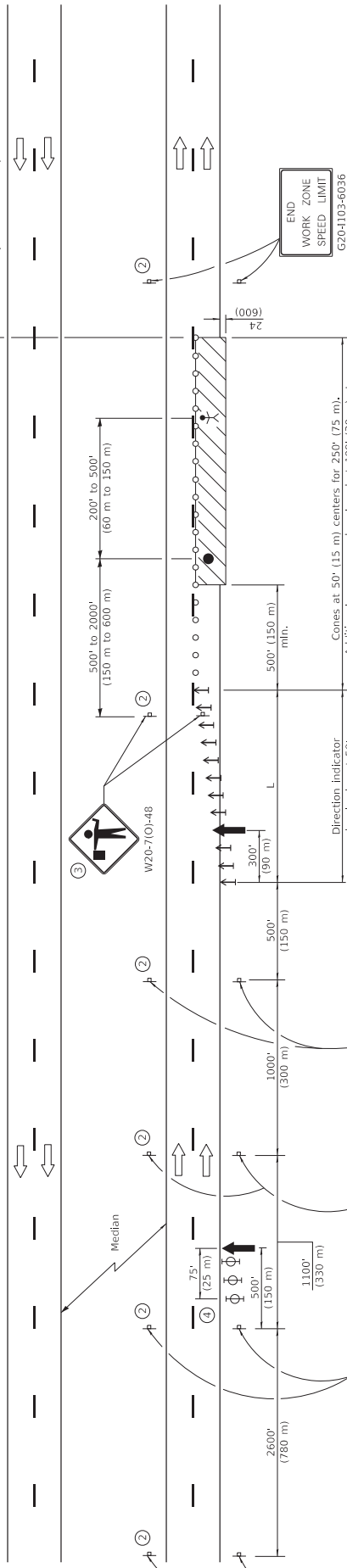
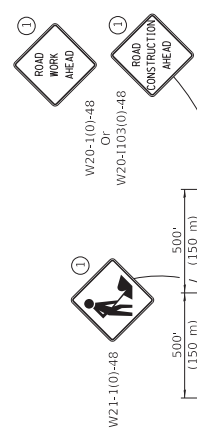

For contract construction projects

For maintenance and utility projects

Direction indicator barrels at 50' (15 m) centers

Cones at 50' (15 m) centers for 250' (75 m). Additional cones may be placed at 100' (30 m) ctrs.

When drums or barricades are used, the 50' (15 m) spacing may be doubled.

When drums or barricades are used, the 50' (15 m) spacing may be doubled.

When drums or barricades are used, the 50' (15 m) spacing may be doubled.

When drums or barricades are used, the 50' (15 m) spacing may be doubled.

When drums or barricades are used, the 50' (15 m) spacing may be doubled.

When drums or barricades are used, the 50' (15 m) spacing may be doubled.

WORK ZONE SPEED LIMIT 45

PHOTO ENFORCED

SXXX FINE MINIMUM

W21-105(0)-3618

R2-1-3648

R10-1106p-3618

R2-1106p-3618

W42-2R(0)-48

W42-5(0)-48

W20-103(0)-48

W20-10(0)-48

W20-103(0)-48

W20-10(0)-48

G20-103-6036

G20-103-6036

W20-103(0)-48

W20-10(0)-48

G20-103-6036

G20-103-6036

W20-103(0)-48

W20-10(0)-48

G20-103-6036

G20-103-6036

W20-103(0)-48

W20-10(0)-48

G20-103-6036

G20-103-6036

GENERAL NOTES

This Standard is used where at any time, any vehicle, equipment, workers or their activities will encroach on the lane adjacent to the shoulder, or on the shoulder within 24 (600) of the edge of pavement.

This Standard also applies when work is being performed in the left lane. Under these conditions, LEFT LANE CLOSED signs shall be substituted for RIGHT LANE CLOSED signs. On unidirectional highways, signs shall be added in the opposite direction as shown.

All dimensions are in inches (millimeters) unless otherwise shown.

① Unidirectional roadway only with left lane closure in opposite direction.

② Omitted when median is less than 10' (3 m).

③ FLAGGER signs shall be moved as necessary to maintain the required spacing between the sign and each separate work activity.

④ These Type II barricades, drums, or vertical barricades at 25' (8 m) centers.

TYPICAL APPLICATIONS

Pavement patch
Utility operations
Bituminous resurfacing

Normal Posted Speed	Taper Ratio
mph	
55	55/1
45	45/1

SYMBOLS

- ↑ Arrow board
- ▨ Work area
- ⊥ Sign
- ↑ Direction indicator barricade
- Cone, drum or barricade
- Flagger with traffic control sign
- ⋈ Worker
- ⊕ Type II barricade, drum, or vertical barricade with monodirectional flashing light

LANE CLOSURE, MULTILANE, DAY OPERATIONS ONLY, FOR SPEEDS ≥ 45 MPH TO 55 MPH

STANDARD 701421-08

DATE	REVISIONS
1-1-17	Rev. END WORK ZONE SPEED LIMIT sign. Changed device spacing at first arr. bnd.
1-1-15	Revised END WORK ZONE SPEED LIMIT sign dimensions.

Illinois Department of Transportation
PASSED January 1, 2017
ENGINEER OF SAFETY PROG. AND ENGINEERING
APPROVED January 1, 2017
ENGINEER OF DESIGN AND ENVIRONMENT

ISSUED 4-1-04

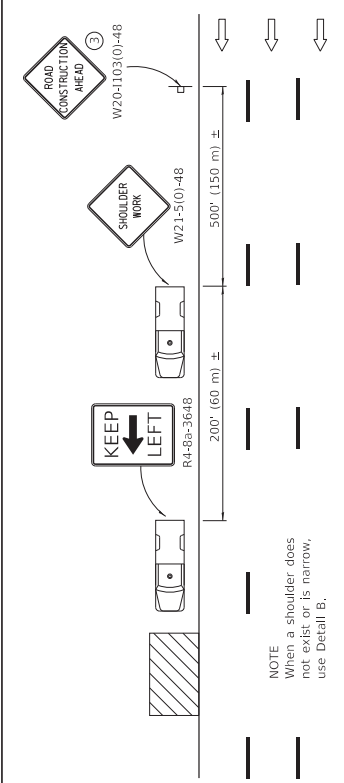

NOTE
When a shoulder does not exist or is narrow, use Detail B.

DETAIL A

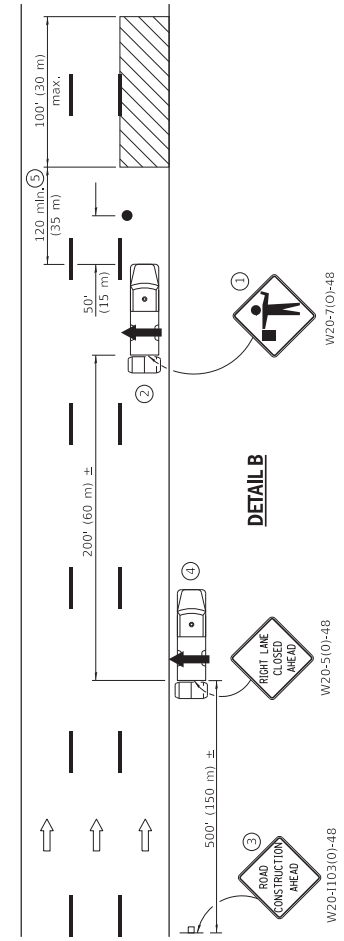

DETAIL B

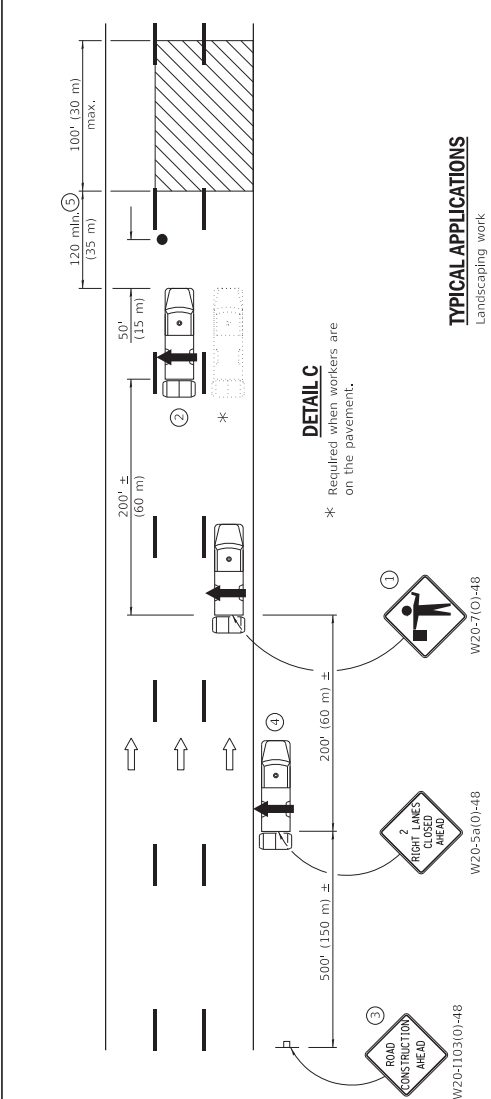

DETAIL C

* Required when workers are on the pavement.

TYPICAL APPLICATIONS

- Landscape work
- Utility work
- Pavement marking
- Weed spraying
- Roadmeter measurements
- Debris cleanup
- Crack pouring

- 1) Flaggers are required when workers are on the pavement.
- 2) For striping operations only. See sign arrow detail on this standard.
- 3) For stationary operations which are on the roadway or shoulder, greater than 15 minutes and up to 1 hour.
- 4) Omit truck, attenuator and arrow board when no shoulder exists due to curb and gutter.
- 5) The distance between the work and the lead truck may vary according to terrain or pain/crack sealing time.



C20-101-2430
(appropriate arrow)
② (when striping only)

GENERAL NOTES

This Standard is used where any vehicle, equipment, workers or their activities will require:
1) stationary operations up to 1 hour, or 2) a continuous or intermittent moving operation where the average speed of movement is greater than 1 mph (2 km/h).

This Standard is also applicable when work is being performed in the left lane(s) or on the median shoulder. Under these conditions, KEEP RIGHT signs shall be substituted for KEEP LEFT signs and arrow board indications shall be directed to the right.

All dimensions are in inches (millimeter) unless otherwise shown.

SYMBOLS

- ↑ Arrow board
- ▨ Work area
- Truck with flashing amber light
- Truck/Trailer mounted attenuator
- Flagger with traffic control sign
- ⊥ Sign

DATE	REVISIONS
1-1-17	Revised 'NOTE' on DETAIL A to use DETAIL B in lieu of DETAIL C.
4-1-16	Rev. gen. notes, Added note ⑤, Rev. dist. between work and lead truck.

Illinois Department of Transportation PASSED <i>Paul S. ...</i> ENGINEER OF SAFETY PROC. AND ENGINEERING APPROVED <i>Michael ...</i> ENGINEER OF DESIGN AND ENVIRONMENT	ISSUED 1-1-11 2017 2017
---	-------------------------------

LANE CLOSURE, MULTILANE, INTERMITTENT OR MOVING OPER., FOR SPEEDS ≤ 40 MPH

STANDARD 701427-05

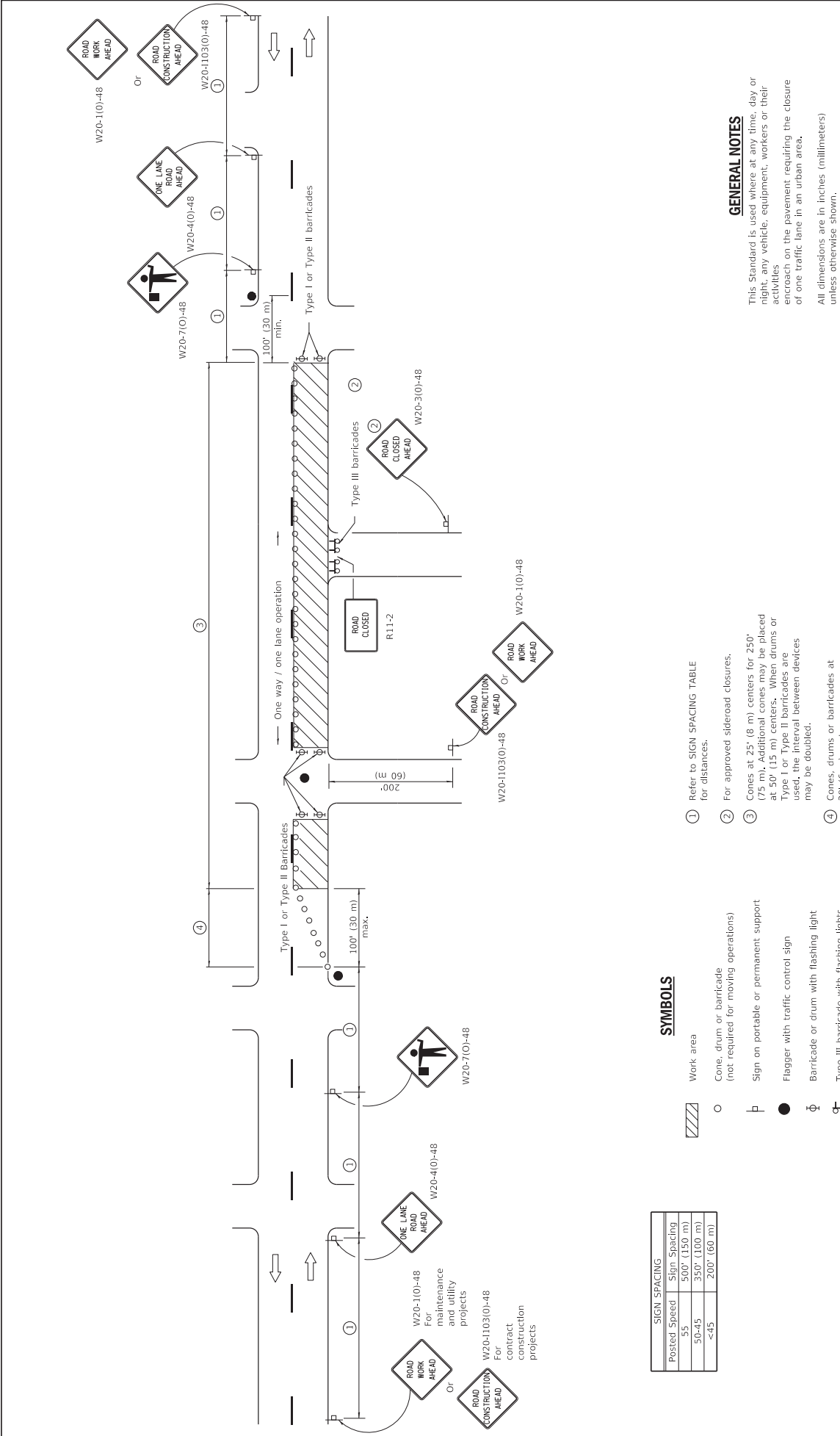

SIGN SPACING	
Posted Speed	Sign Spacing
55	500' (150 m)
50-45	350' (100 m)
<45	200' (60 m)

SYMBOLS

- Work area
- Cone, drum or barricade (not required for moving operations)
- Sign on portable or permanent support
- Flagger with traffic control sign
- Barricade or drum with flashing light
- Type III barricade with flashing lights

- ① Refer to SIGN SPACING TABLE for distances.
- ② For approved sideroad closures.
- ③ Cones at 25' (8 m) centers for 250' (75 m). Additional cones may be placed at 50' (15 m) centers. When drums or Type I or Type II barricades are used, the interval between devices may be doubled.
- ④ Cones, drums or barricades at 20' (6 m) centers.

GENERAL NOTES

This Standard is used where at any time, day or night, any vehicle, equipment, workers or their activities encroach on the pavement requiring the closure of one traffic lane in an urban area.

All dimensions are in inches (millimeters) unless otherwise shown.

URBAN LANE CLOSURE, 2L, 2W, UNDIVIDED	
STANDARD 701501-06	
DATE	REVISIONS
1-1-11	Revised flagger sign.
1-1-09	Switched units to English (metric).
	Corrected sign No.'s.

Illinois Department of Transportation
 PASSED January 1, 2011
 ENGINEER OF SAFETY ENGINEERING
 APPROVED January 1, 2011
 ENGINEER OF DESIGN AND ENVIRONMENT

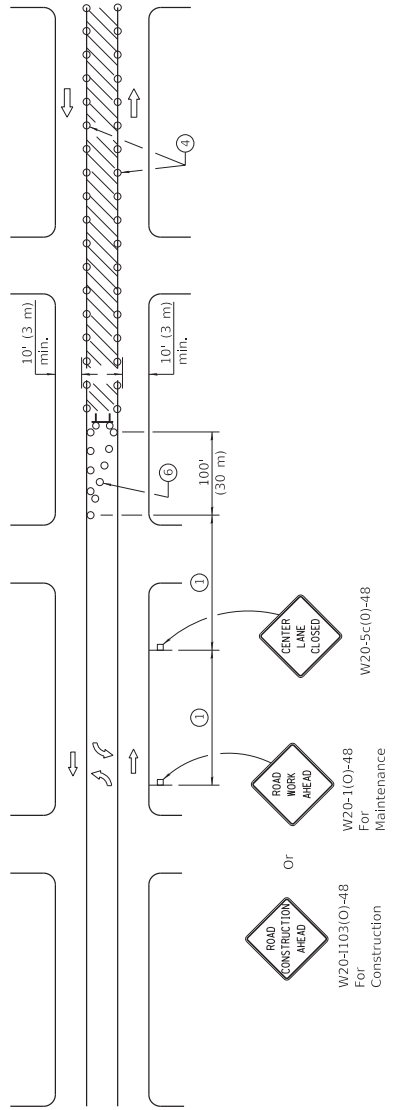

SIGN SPACING	
Posted Speed	Sign Spacing
55	500' (150 m)
50-45	350' (100 m)
<45	200' (60 m)

CASE I

(Signs required for both directions)

- ① Refer to SIGN SPACING TABLE for distances.
- ② Required for speeds > 40 mph (70 km/h).
- ③ Required if work exceeds 500' (164 m) or 1 block.
- ④ Cones at 25' (8 m) centers for 250' (75 m) on approach. Additional cones may be placed at 50' (15 m) centers. When drums or type I or II barricades are used, the interval between devices may be doubled.
- ⑤ For approved sideroad closures.
- ⑥ Cones, drums or barricades at 20' (6 m) centers in taper.
- ⑦ Use flagger sign only when flagger is present.

SYMBOLS

- Work area
- Barricade or drum with flashing light
- Flagger with traffic control sign
- Cone, drum or barricade
- Sign on portable or permanent support
- Type III barricade with flashing lights

GENERAL NOTES

This Standard is used to close one lane of an urban, two lane, two way roadway with a bidirectional turn lane.

Case I applies when no workers are present. When workers are present, two lanes shall be closed and traffic control shall be according to Standard 701501.

Calculate L as follows:

SPEED LIMIT

English (Metric)

$L = \frac{WS^2}{60}$ $L = \frac{WS^2}{150}$

$L = (W)(S)$ $L = 0.65(W)(S)$

40 mph (70 km/h) or less: $L = \frac{WS^2}{60}$ $L = (W)(S)$ $L = 0.65(W)(S)$

45 mph (80 km/h) or greater: $L = \frac{WS^2}{150}$

W = Width of offset in feet (meters).

S = Normal posted speed mph (km/h).

All dimensions are in inches (millimeters) unless otherwise shown.

URBAN LANE CLOSURE, 2L, 2W, WITH BIDIRECTIONAL LEFT TURN LANE

(Sheet 1 of 2)

STANDARD 701502-09

DATE	REVISIONS
1-1-19	Revised to allow cones at night.
1-1-18	Corrected sign number for TWO WAY TRAFFIC sign for CASE II.

Illinois Department of Transportation

APPROVED January 1, 2019

Cynthia C. ...
ENGINEER OF SAFETY PROC. AND ENGINEERING

APPROVED January 1, 2019

... ..
ENGINEER OF DESIGN AND ENVIRONMENT

ISSUED 1-1-01

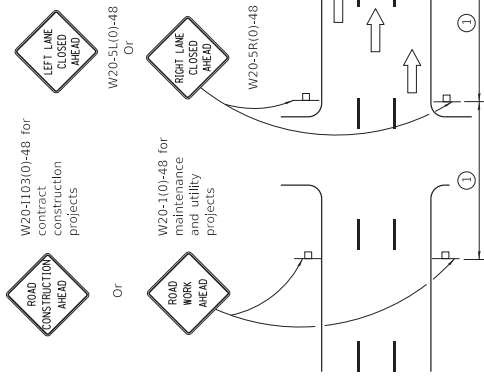

Posted Speed	Sign Spacing
55	500' (150 m)
50-45	350' (100 m)
<45	200' (60 m)

SYMBOLS

- ↑ Arrow board
- Cone, drum or barricade
- ⊥ Sign on portable or permanent support
- ▨ Work area
- ⊕ Barricade or drum with flashing light
- ⊕ Type III barricade with flashing lights
- Flagger with traffic control sign.

- 1 Refer to SIGN SPACING TABLE for distances.
- 2 Required for speeds > 40 MPH
- 3 Cones at 25' (8 m) centers for 250' (75 m). Additional cones may be placed at 50' (15 m) centers. When drums or Type I or Type II barricades are used, the interval between devices may be doubled.
- 4 Use flagger sign only when flagger is present.
- 5 For approved sideroad closures.
- 6 Cones, drums or barricades at 20' (6 m) in taper.

GENERAL NOTES

This Standard is used where at any time, day or night, any vehicle, equipment, workers or their activities encroach on the pavement during shoulder operations or where construction requires lane closures in urban areas.

Calculate L as follows:

SPEED LIMIT	FORMULAS
English	(Metric)
40 mph (70 km/h)	$L = \frac{WS^2}{60}$
or less:	$L = 150$
45 mph (80 km/h)	$L = \frac{W(S)}{15}$
or greater:	$L = 0.65(W)(S)$

W = Width of offset
In feet (meters).

S = Normal posted speed
mph (km/h).

All dimensions are in inches (millimeters) unless otherwise shown.

DATE	REVISIONS
1-1-14	Revised workers sign number to agree with current MUTCD.
1-1-13	Omitted text: 'WORKERS' sign.

URBAN LANE CLOSURE, MULTILANE, 1W OR 2W WITH NONTRAVERSABLE MEDIAN
(Sheet 1 of 2)

STANDARD 701601-09

Illinois Department of Transportation

PASSED January 2014
 APPROVED January 2014
 ENGINEER OF SAFETY ENGINEERING
 ENGINEER OF DESIGN AND ENVIRONMENT

ISSUED 1-1-07

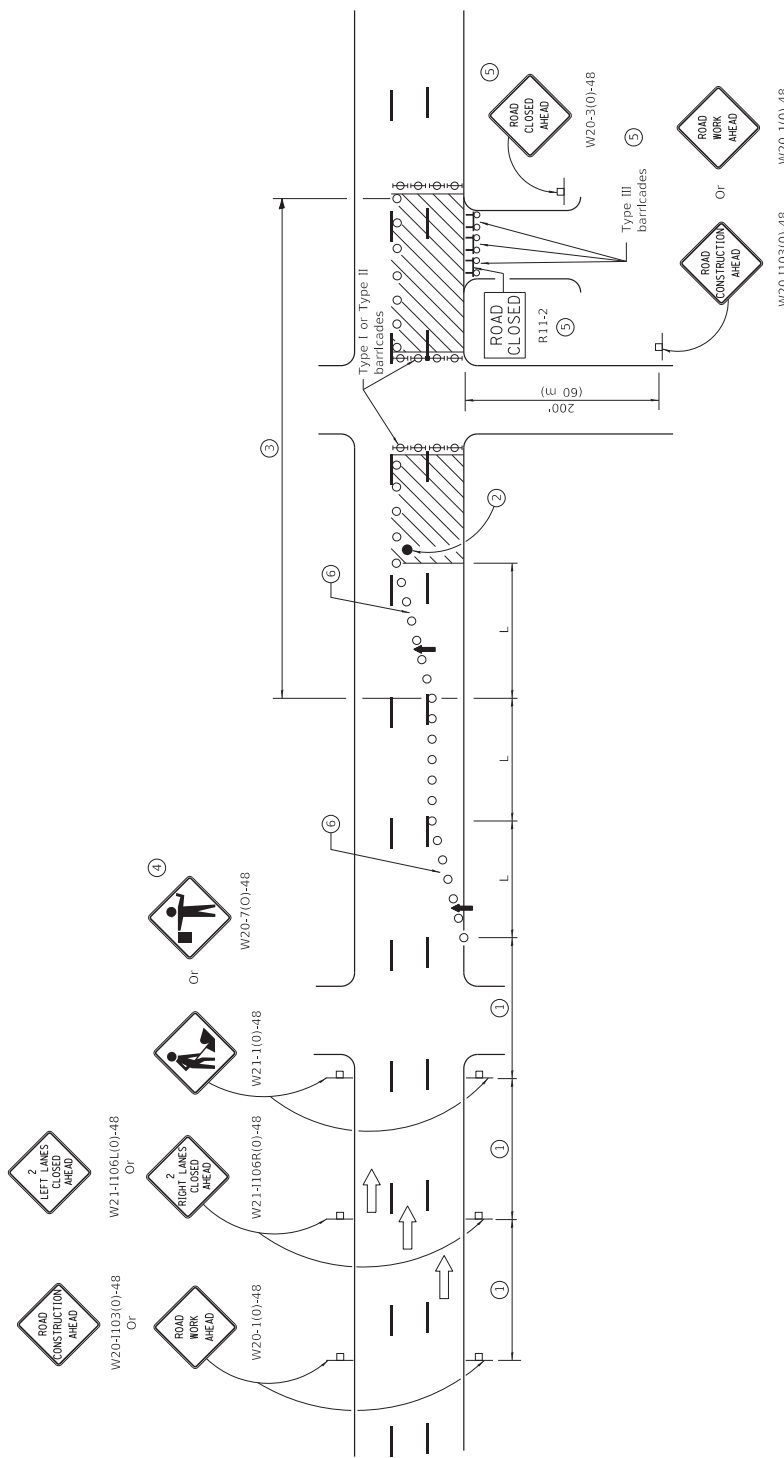

**URBAN LANE CLOSURE,
MULTILANE, 1W OR 2W WITH
NONTRAVERSABLE MEDIAN**
(Sheet 2 of 2)

STANDARD 701601-09

Illinois Department of Transportation PASSED ENGINEER OF SAFETY ENGINEERING APPROVED ENGINEER OF DESIGN AND ENVIRONMENT	ISSUED 1-1-97
	2014 2014 2014

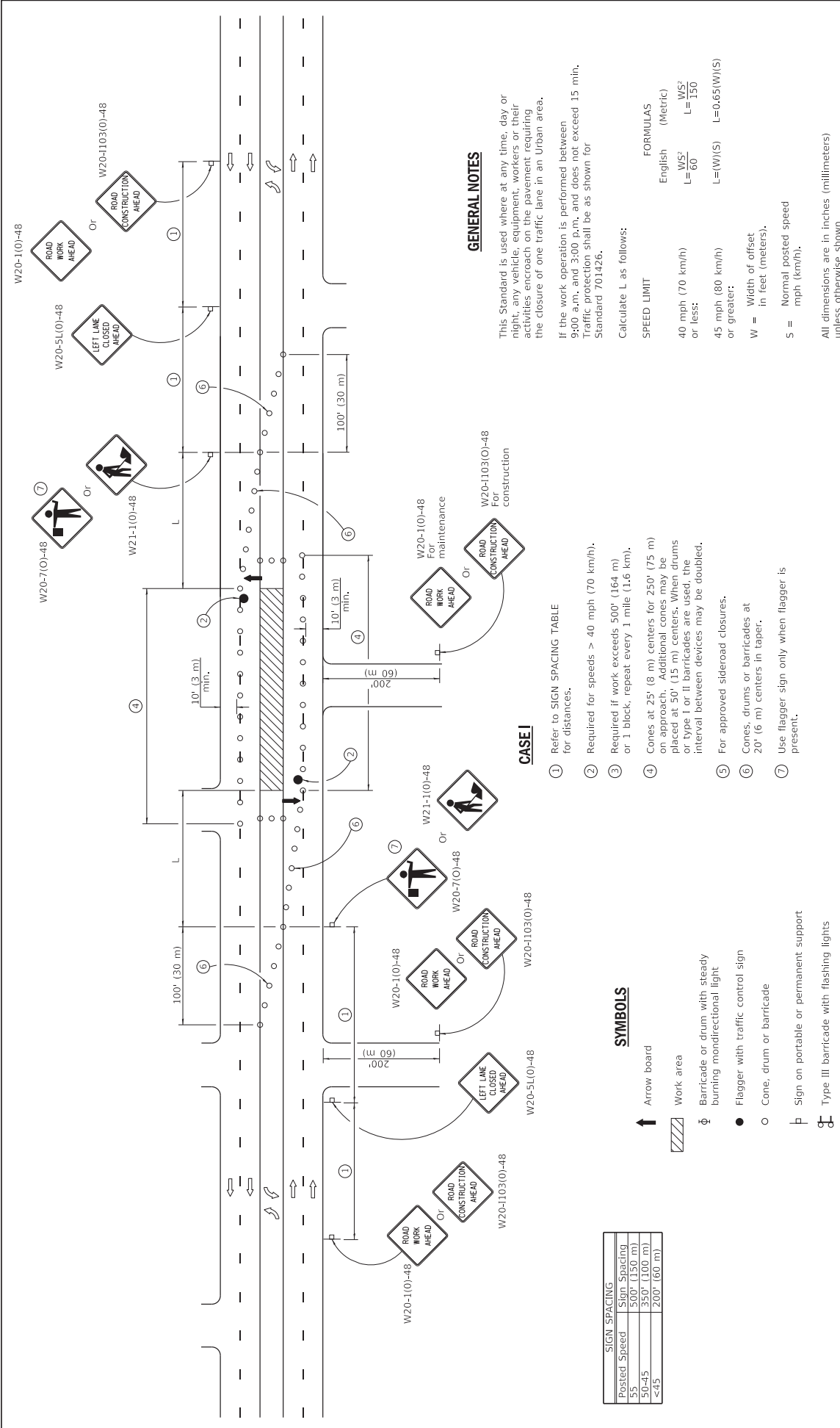

W20-1(0)-48

W20-5L(0)-48

W20-7(O)-48

W20-1(0)-48

W20-1(0)-48

W20-1(0)-48

W20-1(0)-48

W20-1(0)-48

W20-1(0)-48

GENERAL NOTES

This Standard is used where at any time, day or night any vehicle, equipment, workers or their activities encroach on the pavement requiring the closure of one traffic lane in an Urban area.

If the work operation is performed between 9:00 a.m. and 3:00 p.m., and does not exceed 15 min. Traffic protection shall be as shown for Standard 701426.

Calculate L as follows:

SPEED LIMIT

English (Metric)

40 mph (70 km/h)

or less: $L = \frac{WS^2}{60}$

45 mph (80 km/h)

or greater: $L = \frac{WS^2}{60}$

$W =$ Width of offset in feet (meters).

$S =$ Normal posted speed mph (km/h).

FORMULAS

English (Metric)

$L = \frac{WS^2}{60}$

$L = 0.65(W)(S)$

CASE I

- Refer to SIGN SPACING TABLE for distances.
- Required for speeds > 40 mph (70 km/h).
- Required if work exceeds 500' (164 m) or 1 block, repeat every 1 mile (1.6 km).
- Cones at 25' (8 m) centers for 250' (75 m) on approach. Additional cones may be placed at 50' (15 m) centers. When drums or Type I or II barricades are used, the interval between devices may be doubled.
- For approved sideroad closures.
- Cones, drums or barricades at 20' (6 m) centers in taper.
- Use flagger sign only when flagger is present.

SYMBOLS

- ↑ Arrow board
- ▨ Work area
- ⊠ Barricade or drum with steady burning mondirectional light
- Flagger with traffic control sign
- Cone, drum or barricade
- ⏏ Sign on portable or permanent support
- ⊠ Type III barricade with flashing lights

SIGN SPACING	
Posted Speed	Sign Spacing
35	500' (150 m)
30-45	350' (100 m)
<45	200' (60 m)

<p>URBAN LANE CLOSURE, MULTILANE, 2W WITH BIDIRECTIONAL LEFT TURN LANE</p> <p>(Sheet 1 of 4)</p>		
DATE	REVISIONS	
1-1-19	Revised to allow cones at night.	
1-1-18	Moved arrow boards into closed lanes for CASE I.	
<p>STANDARD 701602-10</p>		

APPROVED

Cynthia D. ...
ENGINEER OF SAFETY PROC. AND ENGINEERING

APPROVED

...
ENGINEER OF DESIGN AND ENVIRONMENT

Illinois Department of Transportation

January 1, 2019

ISSUED 1-1-13

**URBAN LANE CLOSURE,
MULTILANE, 2W WITH
BIDIRECTIONAL LEFT TURN LANE**
(Sheet 2 of 4)

STANDARD 701602-10

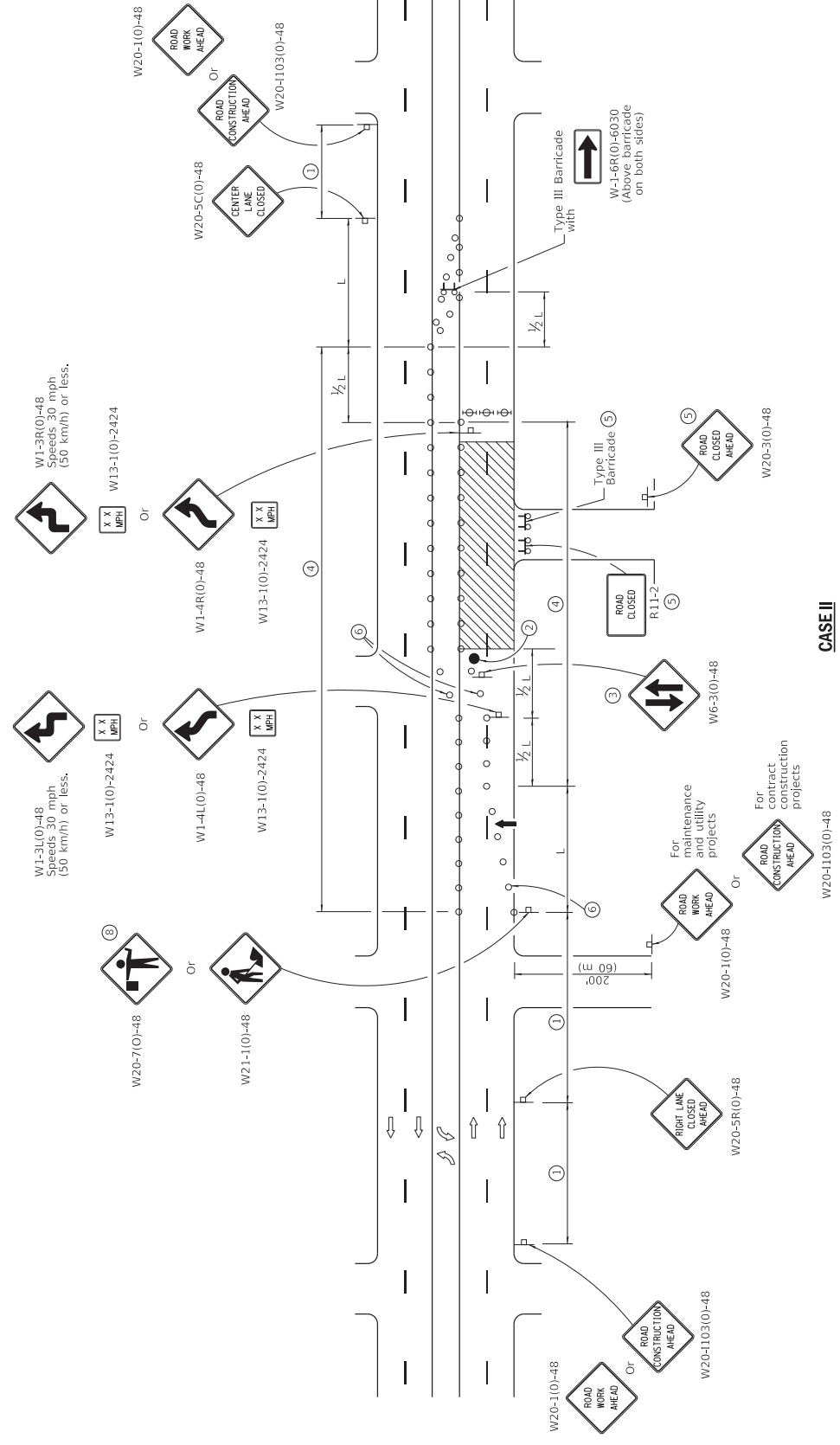

Illinois Department of Transportation
 APPROVED January 1, 2019
 ENGINEER OF SAFETY PROC. AND ENGINEERING
 APPROVED January 1, 2019
 ENGINEER OF DESIGN AND ENVIRONMENT

ISSUED 1-1-13

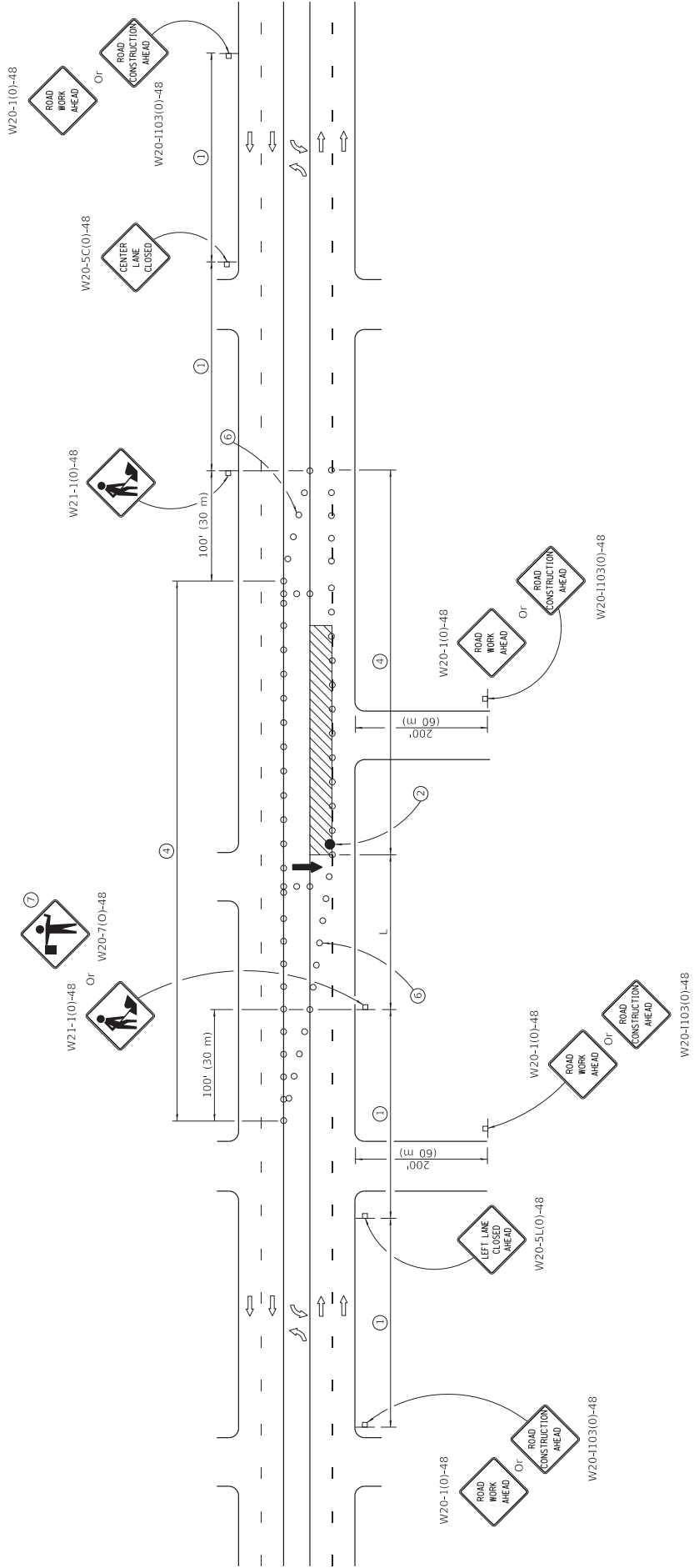

CASE III

**URBAN LANE CLOSURE,
MULTILANE, 2W WITH
BIDIRECTIONAL LEFT TURN LANE**
(Sheet 3 of 4)

STANDARD 701602-10

Illinois Department of Transportation 	ISSUED 1-1-13
	APPROVED January 1, 2019 CYNTHIA OTT ENGINEER OF SAFETY PROC. AND ENGINEERING
	APPROVED January 1, 2019 ROBERT E. SELLS ENGINEER OF DESIGN AND ENVIRONMENT

**URBAN LANE CLOSURE,
MULTILANE, 2W WITH
BIDIRECTIONAL LEFT TURN LANE**
(Sheet 4 of 4)

STANDARD 701602-10

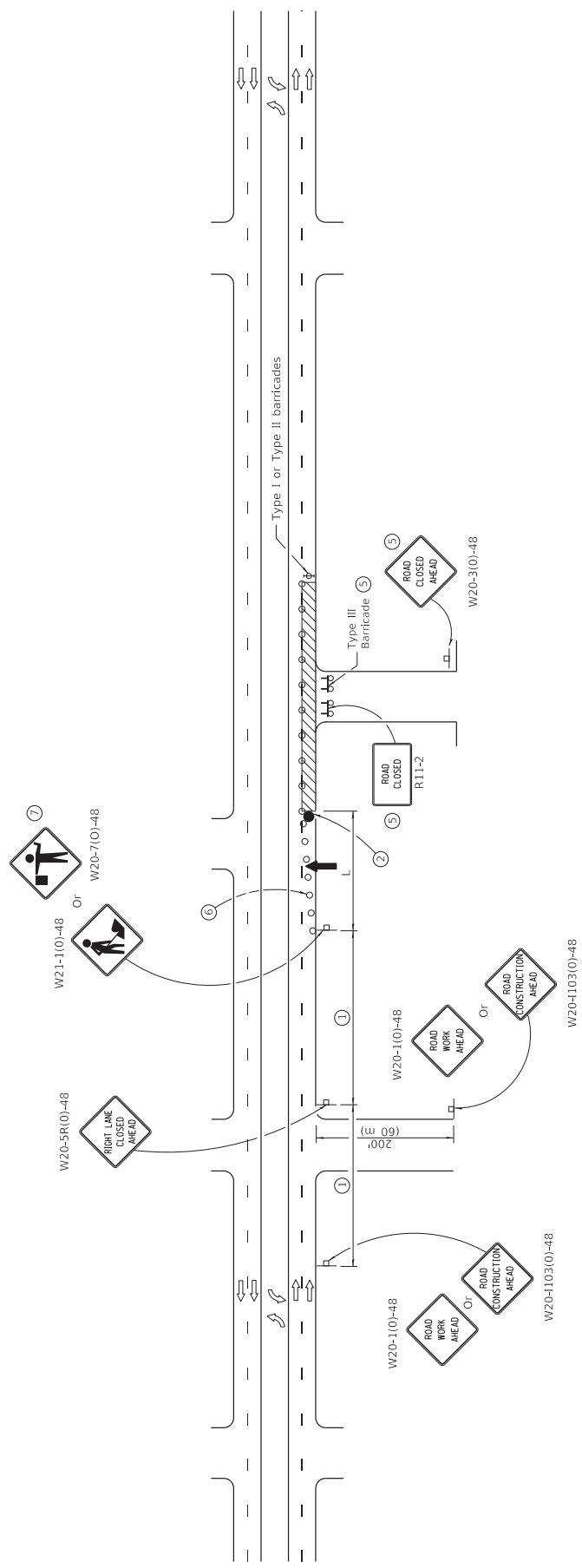

Illinois Department of Transportation
 APPROVED January 1, 2019
 ENGINEER OF SAFETY PROC. AND ENGINEERING
 APPROVED January 1, 2019
 ENGINEER OF DESIGN AND ENVIRONMENT

ISSUED 1-1-13

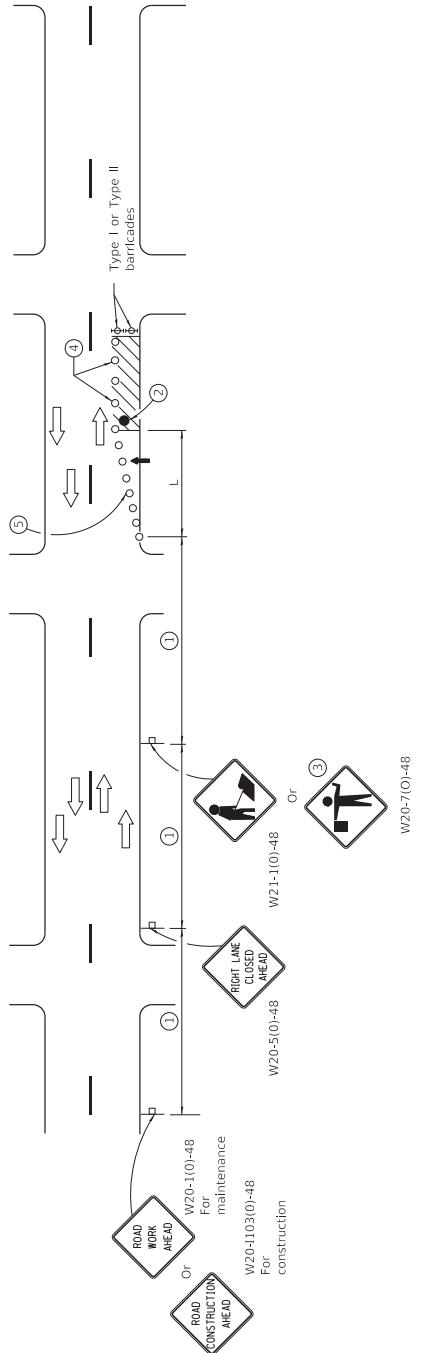

GENERAL NOTES

This Standard is used where at any time, day or night, any vehicle, equipment, workers or their activities encroach on the pavement requiring the closure of one traffic lane in an Urban area.

Calculate L as follows:

SPEED LIMIT	FORMULAS
40 mph (70 km/h) or less:	English (Metric) $L = \frac{WS^2}{60}$ $L = \frac{WS^2}{150}$
45 mph (80 km/h) or greater:	$L = W(V)(S)$ $L = 0.65(W)(S)$

W = Width of offset in feet (meters).
S = Normal posted speed mph (km/h).

All dimensions are in inches (millimeters) unless otherwise shown.

TABLE FOR SIGN SPACING

- Refer to SIGN SPACING TABLE for distances.
- Required for speeds > 40 mph.
- Use flagger sign only when flagger is present.
- Cones at 25' (8 m) centers for 250' (75 m). Additional cones may be placed at 50' (15 m) centers. When drums or Type I or Type II barricades are used, the interval between devices may be doubled.
- Cones, drums or barricades at 20' (6 m) centers in taper.

SYMBOLS

- ↑ Arrow board
- Cone, drum or barricade
- ⊥ Sign on portable or permanent support
- ▨ Work area
- ⊕ Barricade or drum with flashing light
- Flagger with traffic control sign.

Posted Speed	Sign Spacing
55	500' (150 m)
50-45	350' (100 m)
<45	200' (60 m)

URBAN SINGLE LANE CLOSURE, MULTILANE, 2W WITH MOUNTABLE MEDIAN

STANDARD 701606-10

DATE	REVISIONS
1-1-15	Renamed standard. Moved case on Sheet 2 to new Highway Standard.
1-1-14	Revised workers sign number to agree with current MUTCD.

Illinois Department of Transportation

PASSED January 2015
 APPROVED January 1, 2015
 ENGINEER OF SAFETY ENGINEERING
 ENGINEER OF DESIGN AND ENVIRONMENT

ISSUED 1-1-07

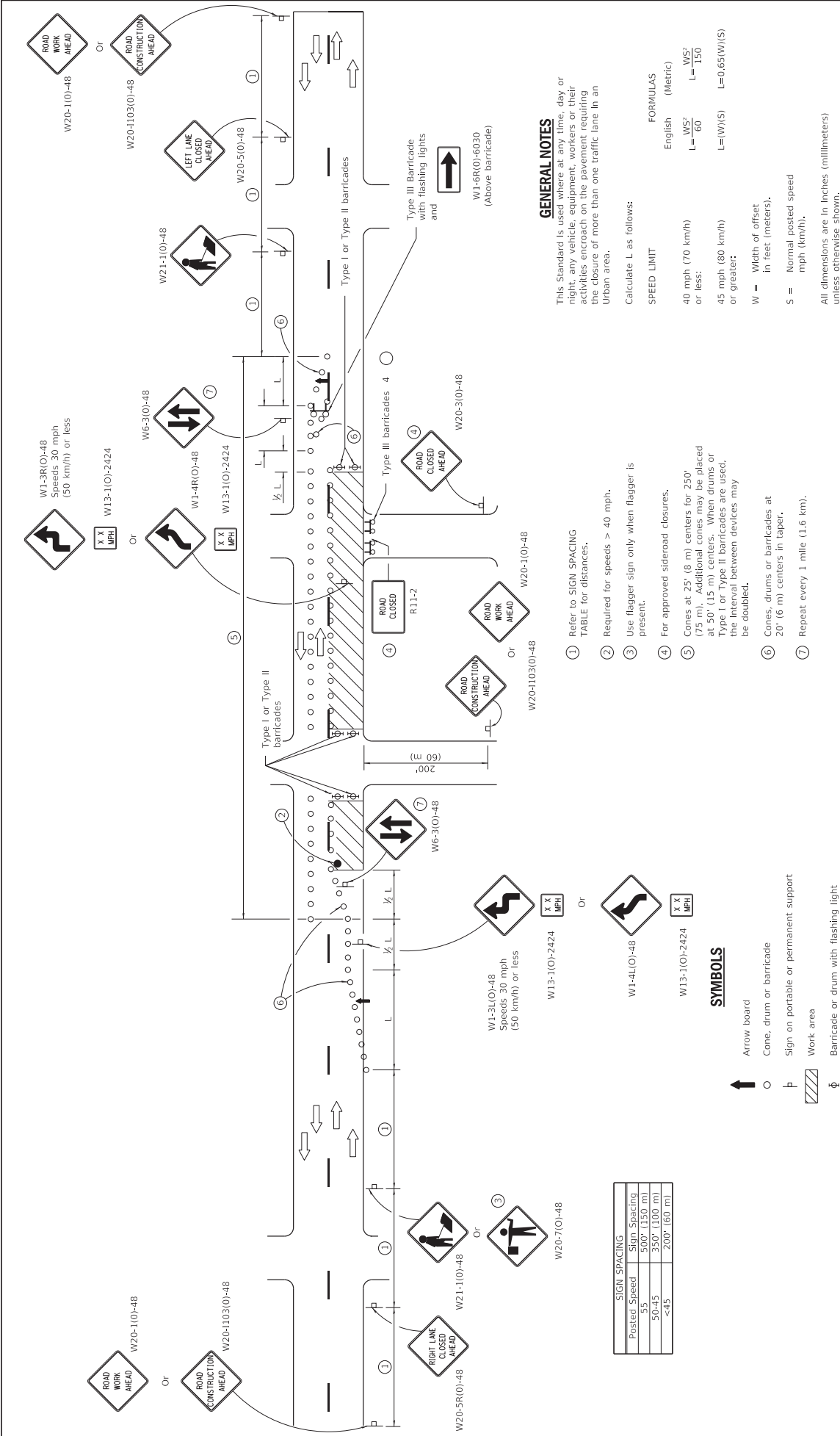

GENERAL NOTES
 This Standard is used where at any time, day or night, any vehicle, equipment, workers or their activities encroach on the pavement requiring the closure of more than one traffic lane in an Urban area.

Calculate L as follows:

SPEED LIMIT	FORMULAS
English	(Metric)
40 mph (70 km/h) or less:	$L = \frac{WS^2}{60}$ $L = 150$
45 mph (80 km/h) or greater:	$L = W(S)$ $L = 0.65(W)(S)$

W = Width of offset in feet (meters).
 S = Normal posted speed mph (km/h).

All dimensions are in inches (millimeters) unless otherwise shown.

- 1 Refer to SIGN SPACING TABLE for distances.
- 2 Required for speeds > 40 mph.
- 3 Use flagger sign only when flagger is present.
- 4 For approved sideroad closures.
- 5 Cones at 25' (8 m) centers for 250' (75 m). Additional cones may be placed at 50' (15 m) centers. When drums or Type I or Type II barricades are used, the interval between devices may be doubled.
- 6 Cones, drums or barricades at 20' (6 m) centers in taper.
- 7 Repeat every 1 mile (1.6 km).

SYMBOLS

- ↑ Arrow board
- Cone, drum or barricade
- ⊥ Sign on portable or permanent support
- ▨ Work area
- ⊕ Barricade or drum with flashing light
- ⊕ Type III barricade with flashing lights
- ⊕ Flagger with traffic control sign.

URBAN HALF ROAD CLOSURE, MULTILANE, 2W WITH MOUNTABLE MEDIAN

DATE	REVISIONS
4-1-16	Moved first reverse curve/turn sign to middle of tangent.
1-1-15	New Standard.

STANDARD 701611-01

Illinois Department of Transportation

PASSED APRIL 1, 2016
 ENGINEER OF SAFETY ENGINEERING

APPROVED APRIL 1, 2016
 ENGINEER OF DESIGN AND ENVIRONMENT

ISSUED 1-1-15

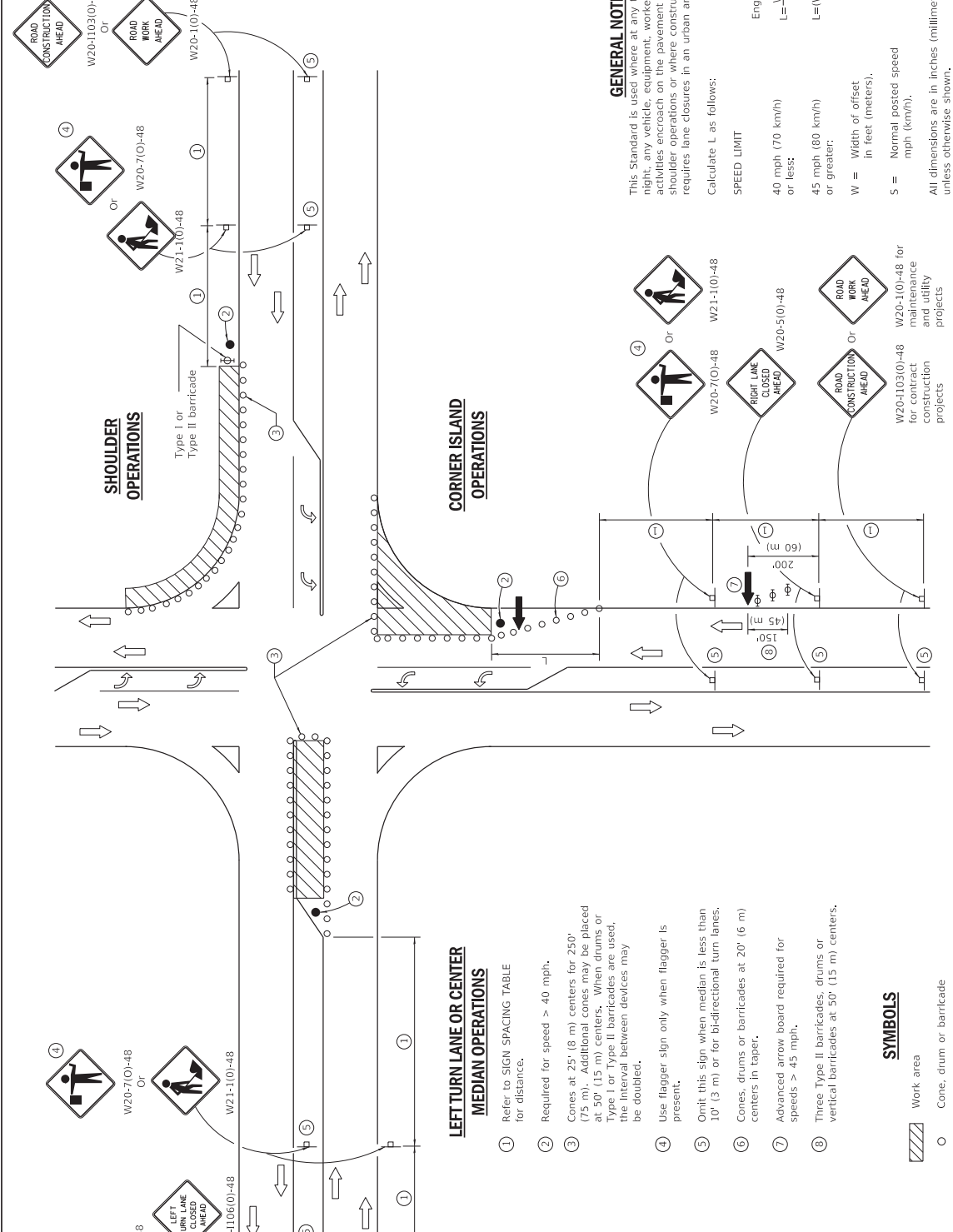

LEFT TURN LANE OR CENTER MEDIAN OPERATIONS

1 Refer to SIGN SPACING TABLE for distance.

2 Required for speed > 40 mph.

3 Cones at 25' (8 m) centers for 250' (75 m). Additional cones may be placed at 50' (15 m) centers. When drums or Type I or Type II barricades are used, the interval between devices may be doubled.

4 Use flagger sign only when flagger is present.

5 Omit this sign when median is less than 10' (3 m) or for bi-directional turn lanes.

6 Cones, drums or barricades at 20' (6 m) centers in taper.

7 Advanced arrow board required for speeds > 45 mph.

8 Three Type II barricades, drums or vertical barricades at 50' (15 m) centers.

SIGN SPACING	
Posted Speed	Sign Spacing
55	500' (150 m)
50-45	350' (100 m)
<45	200' (60 m)

SYMBOLS

- Work area
- Cone, drum or barricade
- Sign on portable or permanent support
- Arrow board
- Barricade or drum with flashing light
- Flagger with traffic control sign

GENERAL NOTES

This Standard is used where at any time, day or night, any vehicle, equipment, workers or their activities encroach on the pavement during shoulder operations or where construction requires lane closures in an urban area.

Calculate L as follows:

SPEED LIMIT	FORMULAS
	(Metric)
English	$L = WS^2 / 60$
Metric	$L = WS^2 / 150$
40 mph (70 km/h) or less:	$L = (W)(S) / 0.65$
45 mph (80 km/h) or greater:	$L = (W)(S) / 0.65$

W = Width of offset in feet (meters).

S = Normal posted speed in mph (km/h).

All dimensions are in inches (millimeters) unless otherwise shown.

DATE	REVISIONS
4-1-16	Corrected sign number for LEFT TURN LANE CLOSED AHEAD.
1-1-14	Added devices at arrow board upstream from taper.
	Rev. workers sign number.

URBAN LANE CLOSURE, MULTILANE INTERSECTION

ILLINOIS Department of Transportation

ISSUED 1-1-07

PASSED April 1, 2016

APPROVED April 1, 2016

ENGINEER OF SAFETY ENGINEERING

ENGINEER OF DESIGN AND ENVIRONMENT

STANDARD 701701-10

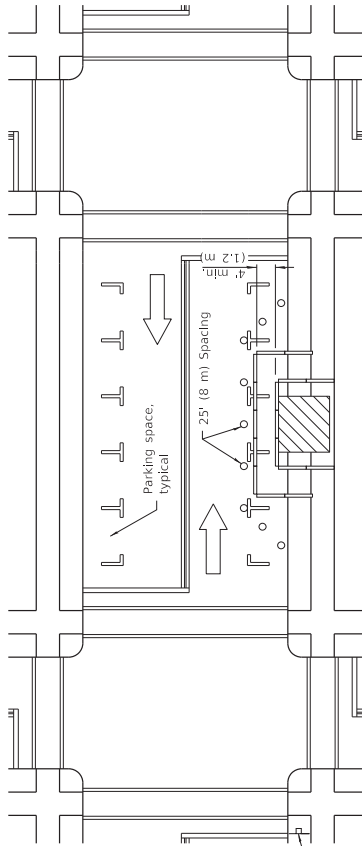

① W20-1103(10)-48 for contract construction projects

Or

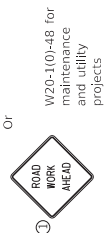

① W20-110-48 for maintenance and utility projects

SIDEWALK DIVERSION

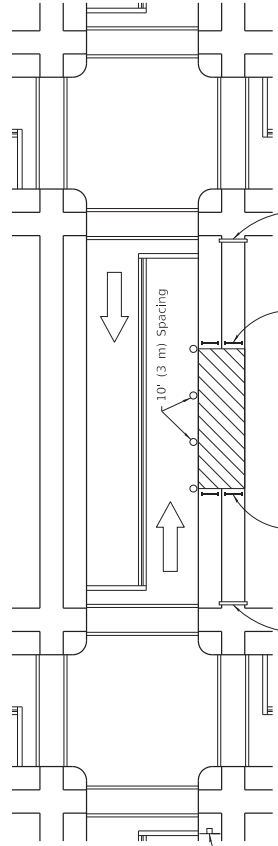

① W20-1103(10)-48 for contract construction projects







Or



① W20-110-48 for maintenance and utility projects

SIDEWALK CLOSURE

SYMBOLS

-  Work area
-  Sign on portable or permanent support
-  Barricade or drum
-  Cone, drum or barricade
-  Type III barricade
-  Detectable pedestrian channelizing barricade

GENERAL NOTES

- The Standard is used where, at any time, pedestrian traffic must be rerouted due to work being performed.
- This Standard must be used in conjunction with other Traffic Control & Protection Standards when roadway traffic is affected.
- Temporary facilities shall be detectable and accessible.
- The temporary pedestrian facilities shall be provided on the same side of the closed facilities whenever possible.
- The SIDEWALK CLOSED / USE OTHER SIDE sign shall be placed at the nearest crosswalk or intersection to each end of the closure. Where the closure occurs at a corner, the signs shall be erected on the corners of the street from the closure. The SIDEWALK CLOSED signs shall be used at the ends of the actual closures.
- Type III barricades and R11-2-4830 signs shall be positioned as shown in "ROAD CLOSED TO ALL TRAFFIC" detail on Standard 701901.
- All dimensions are in inches (millimeters) unless otherwise shown.

① Omit whenever duplicated by road work traffic control.

DATE	REVISIONS
4-1-16	Omitted orange safety fence from standard as this is covered in the std. spec.
1-1-12	Added SIDEWALK DIVERSION, Modified appearance of plan views, Renamed Std.

SIDEWALK, CORNER OR CROSSWALK CLOSURE

(Sheet 1 of 2)

STANDARD 701801-06

Illinois Department of Transportation
 PASSED April 1, 2016
 ENGINEER OF SAFETY ENGINEERING
 APPROVED April 1, 2016
 ENGINEER OF DESIGN AND ENVIRONMENT

ISSUED 1-1-07

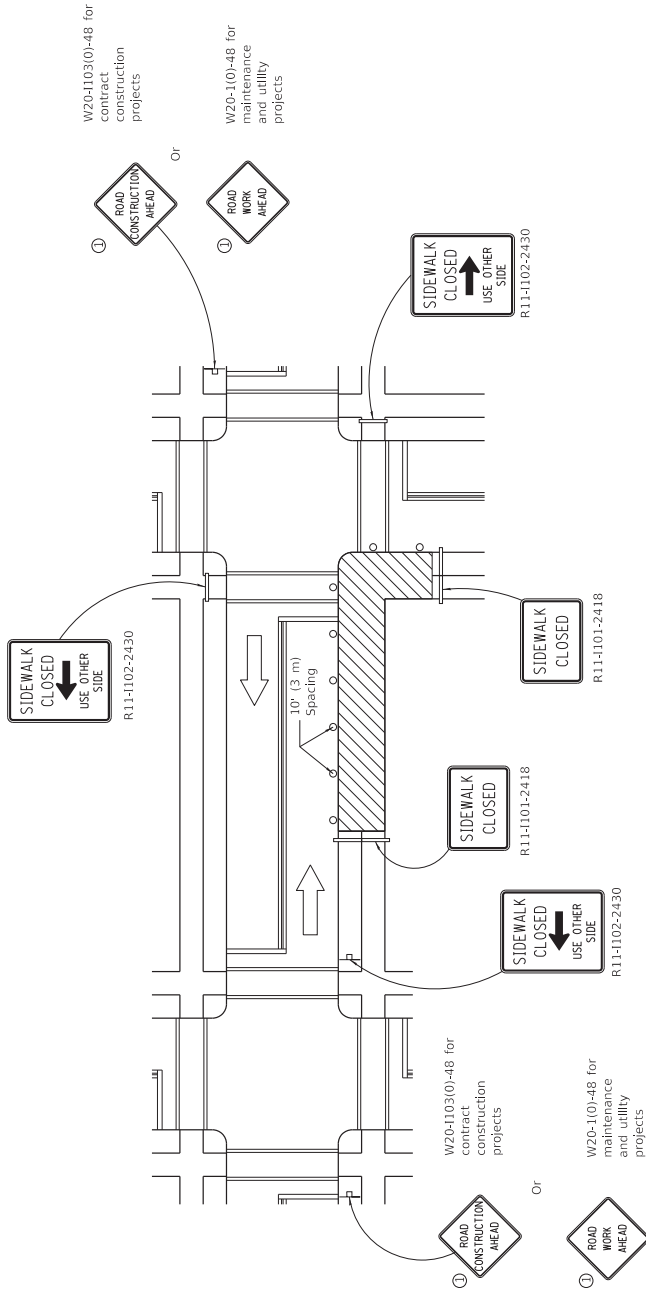

CORNER CLOSURE

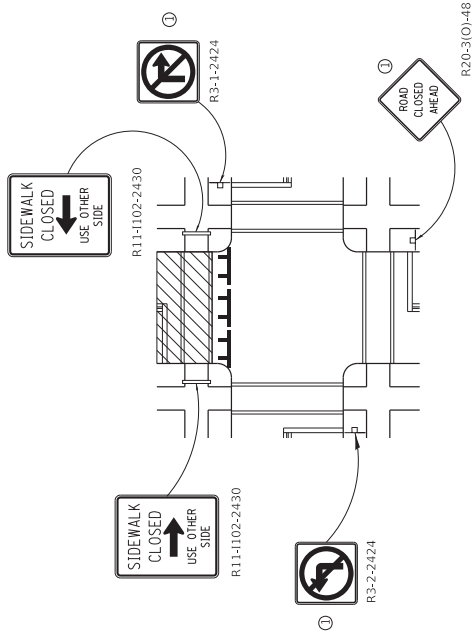

CROSSWALK CLOSURE

SIDEWALK, CORNER OR CROSSWALK CLOSURE

(Sheet 2 of 2)

STANDARD 701801-06

Illinois Department of Transportation PASSED APRIL 11, 2016 ENGINEER OF SAFETY ENGINEERING	ISSUED 1-1-07
	APPROVED APRIL 11, 2016 ENGINEER OF DESIGN AND ENVIRONMENT

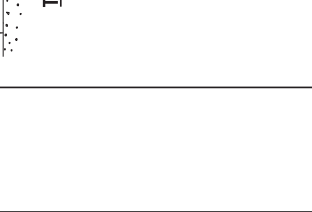
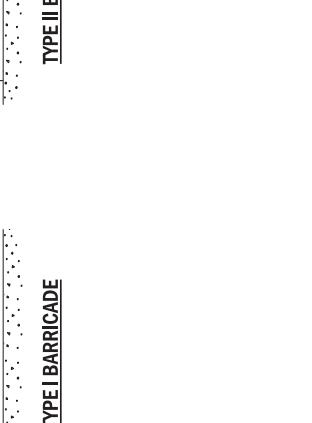
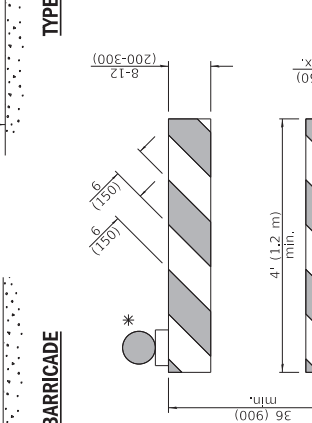
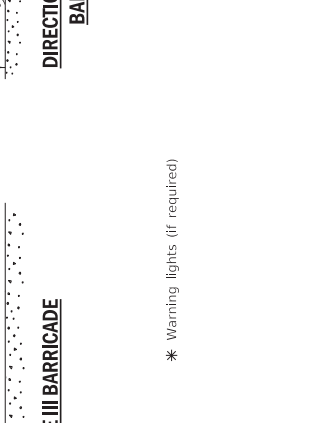
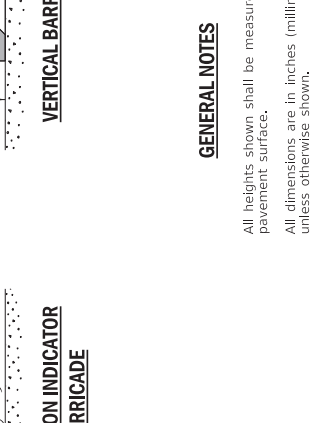
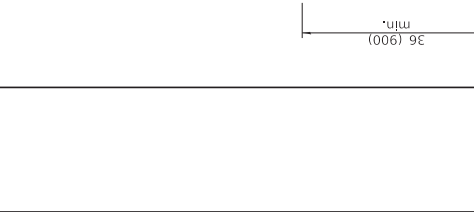
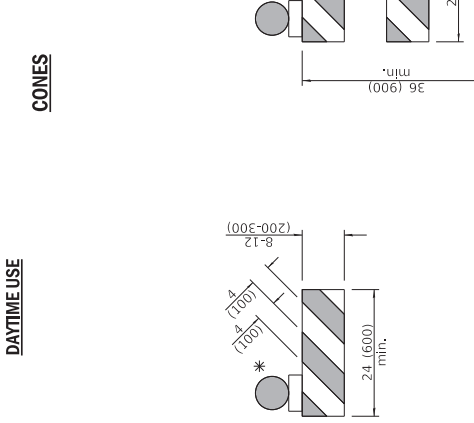
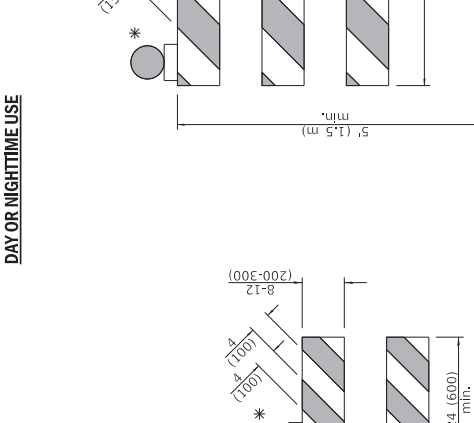
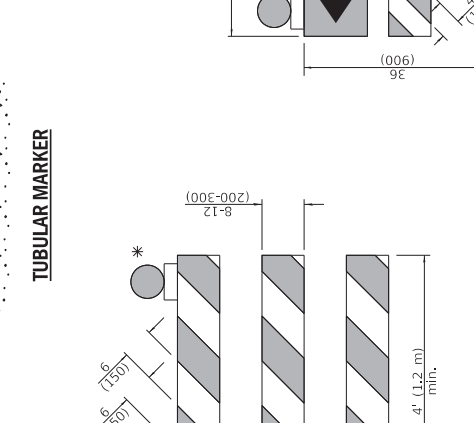
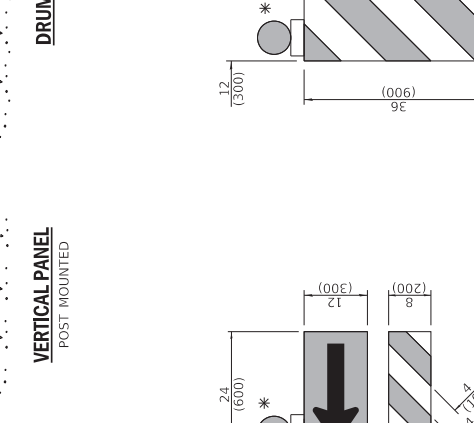
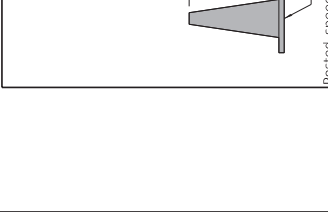
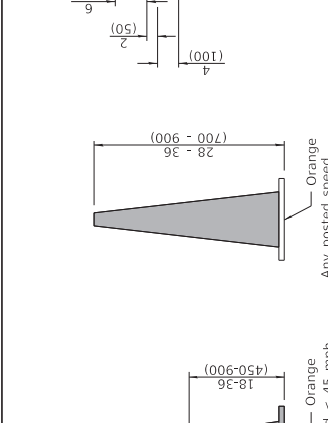
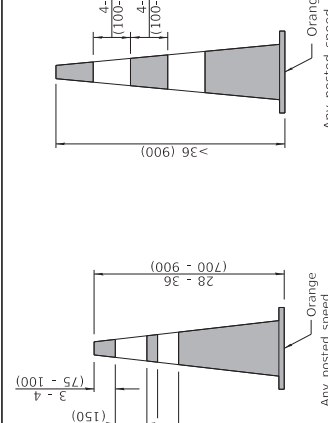
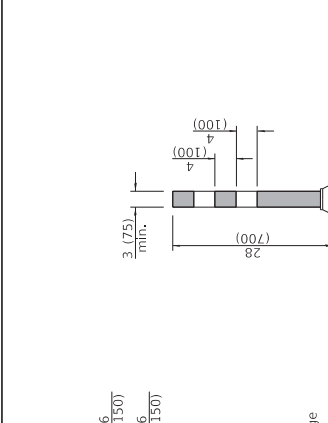
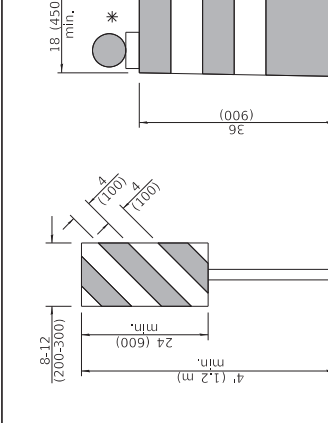

GENERAL NOTES

All heights shown shall be measured above the pavement surface.
All dimensions are in inches (millimeters) unless otherwise shown.

* Warning lights (if required)

DATE	REVISIONS
1-1-19	Revised cone usage and added cones >36" (900 m) height.
1-1-18	Revised END WORK ZONE SPEED LIMIT sign from orange to white background.

TRAFFIC CONTROL DEVICES

STANDARD 701901-08

(Sheet 1 of 3)

Illinois Department of Transportation
 APPROVED January 1, 2019
 [Signature] ENGINEER OF SAFETY PROC. AND ENGINEERING
 APPROVED January 1, 2019
 [Signature] ENGINEER OF DESIGN AND ENVIRONMENT
 ISSUED 1-1-13

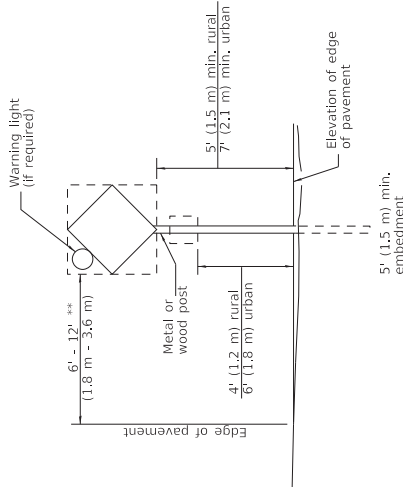

POST MOUNTED SIGNS

** When curb or paved shoulder are present this dimension shall be 24 (600) to the face of curb or 6' (1.8 m) to the outside edge of the paved shoulder.

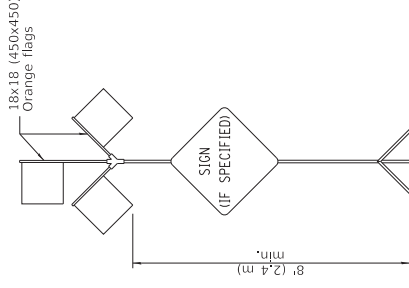

HIGH LEVEL WARNING DEVICE

SIGNS ON TEMPORARY SUPPORTS

*** When work operations exceed four days, this dimension shall be 5' (1.5 m) to the top of the sign behind other devices; the height shall be sufficient to be seen completely above the devices.

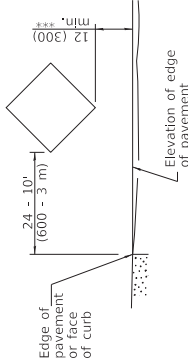

ROAD CONSTRUCTION NEXT X MILES
G20-1104(0)-6036

END CONSTRUCTION
G20-1105(0)-6024

This signing is required for all projects 2 miles (3200 m) or more in length.
ROAD CONSTRUCTION NEXT X MILES sign shall be placed 500' (150 m) in advance of project limits.
END CONSTRUCTION sign shall be erected at the end of the job unless another job is within 2 miles (3200 m).
Dual sign displays shall be utilized on multi-lane highways.

WORK LIMIT SIGNING

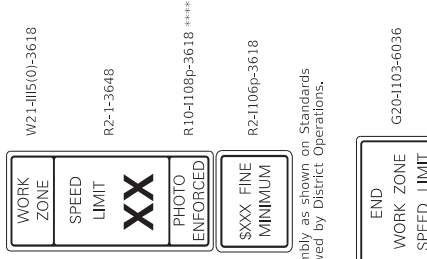

Sign assembly as shown on Standards or as allowed by District Operations.

This sign shall be used when the above sign assembly is used.

HIGHWAY CONSTRUCTION SPEED ZONE SIGNS

**** R10-1108p shall only be used along roadways under the jurisdiction of the State.

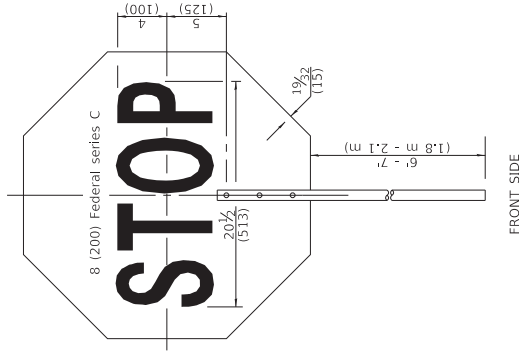

FRONT SIDE

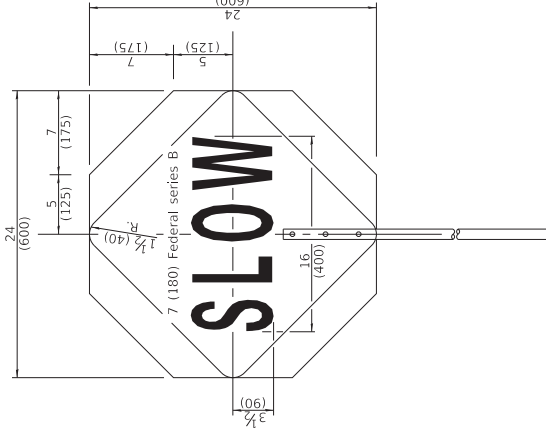

REVERSE SIDE



W12-1103-4848

WIDTH RESTRICTION SIGN

XX-XX" width and X miles are variable.

Illinois Department of Transportation
APPROVED January 1, 2019
Cynthia C. [Signature]
ENGINEER OF SAFETY PROC. AND ENGINEERING
APPROVED January 1, 2019
S. [Signature]
ENGINEER OF DESIGN AND ENVIRONMENT

ISSUED 1-1-13

TRAFFIC CONTROL DEVICES

(Sheet 2 of 3)

STANDARD 701901-08

FLAGGER TRAFFIC CONTROL SIGN

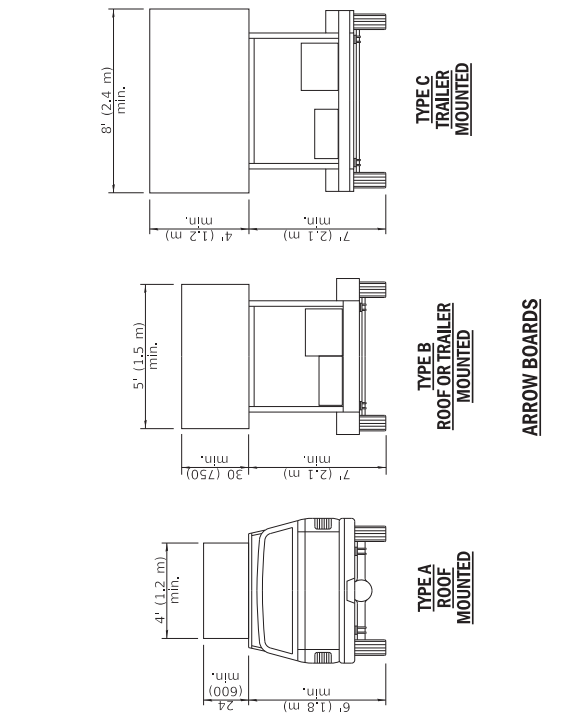
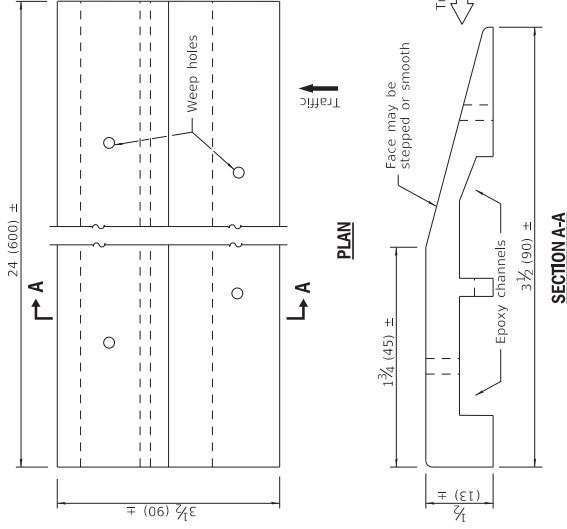
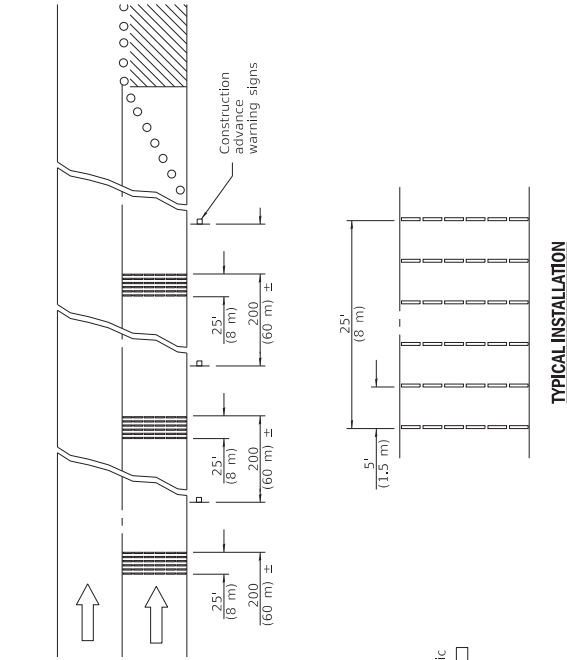

TEMPORARY RUMBLE STRIPS

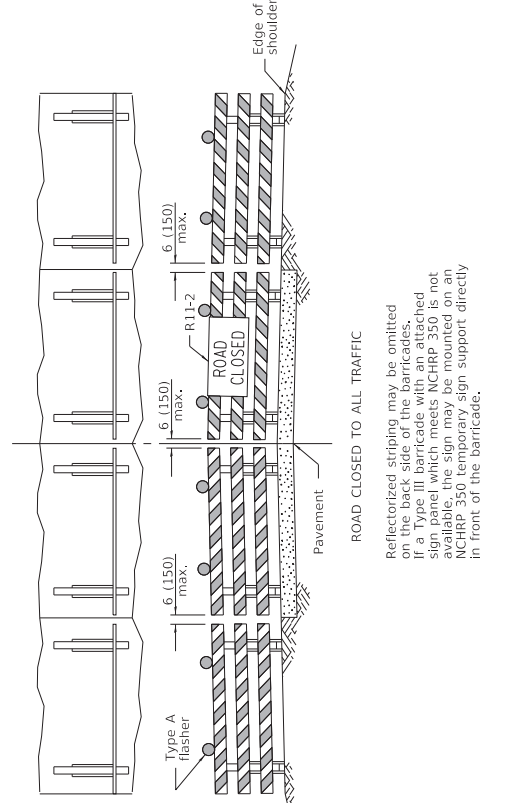
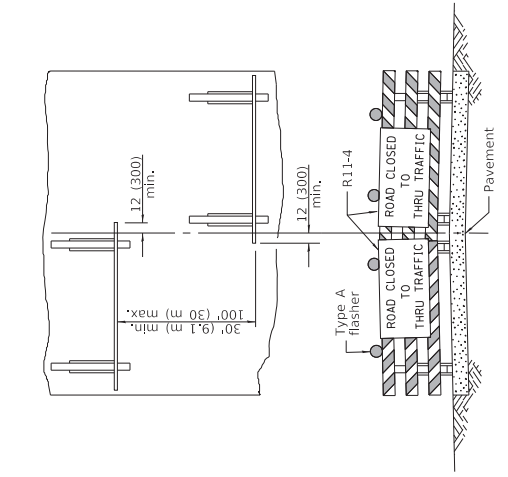

ReflectORIZED striping shall appear on both sides of the barricades. If a type III barricade with reflectORIZED striping is used, MCHRP 350 is not available, the signs may be mounted directly in front of the barricade.

ReflectORIZED striping may be omitted on the back side of the barricades. If a type III barricade without reflectORIZED striping is used, MCHRP 350 is not available, the sign may be mounted on an MCHRP 350 temporary sign support directly in front of the barricade.

TYPICAL APPLICATIONS OF TYPE III BARRICADES CLOSING A ROAD

Illinois Department of Transportation
 APPROVED January 1, 2019
 [Signature]
 ENGINEER OF SAFETY PROC. AND ENGINEERING
 APPROVED January 1, 2019
 [Signature]
 ENGINEER OF DESIGN AND ENVIRONMENT

ISSUED 1-1-13

TRAFFIC CONTROL DEVICES

(Sheet 3 of 3)

STANDARD 701901-08

BUTT JOINT DETAILS

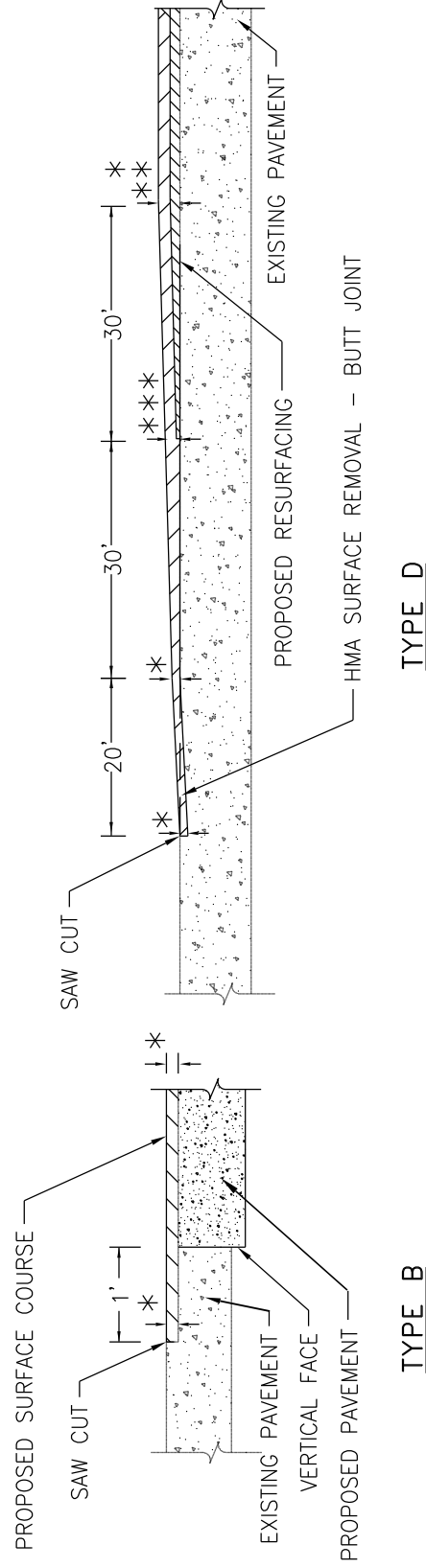
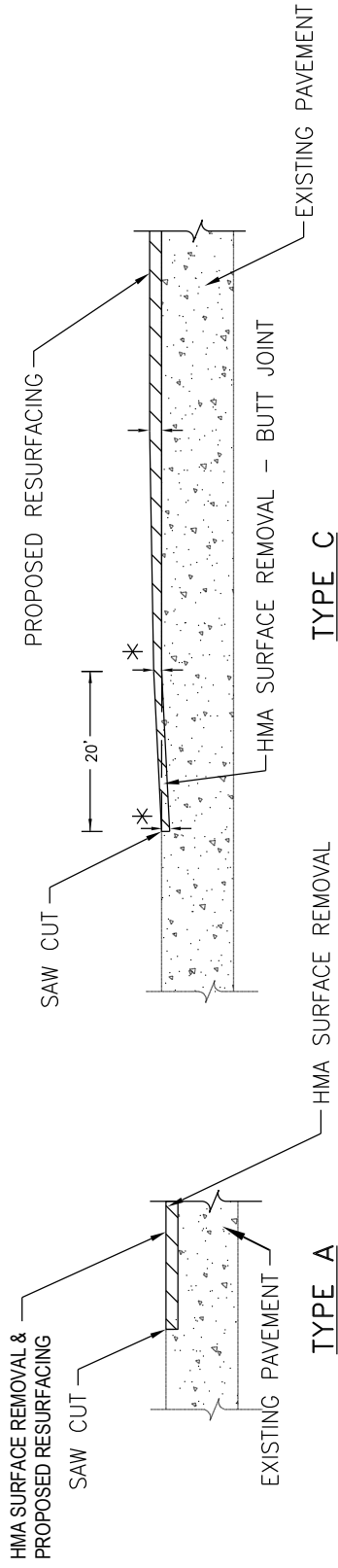

NOTES
 * HMA SURFACE THICKNESS
 ** HMA BINDER OR LEVEL BINDER THICKNESS
 *** MINIMUM HMA LEVEL/BINDER THICKNESS

SAW CUT SHALL NOT BE PAID FOR SEPARATELY
 BUT SHALL BE INCLUDED IN THE COST FOR
 HMA SURFACE REMOVAL OR PAVEMENT REMOVAL

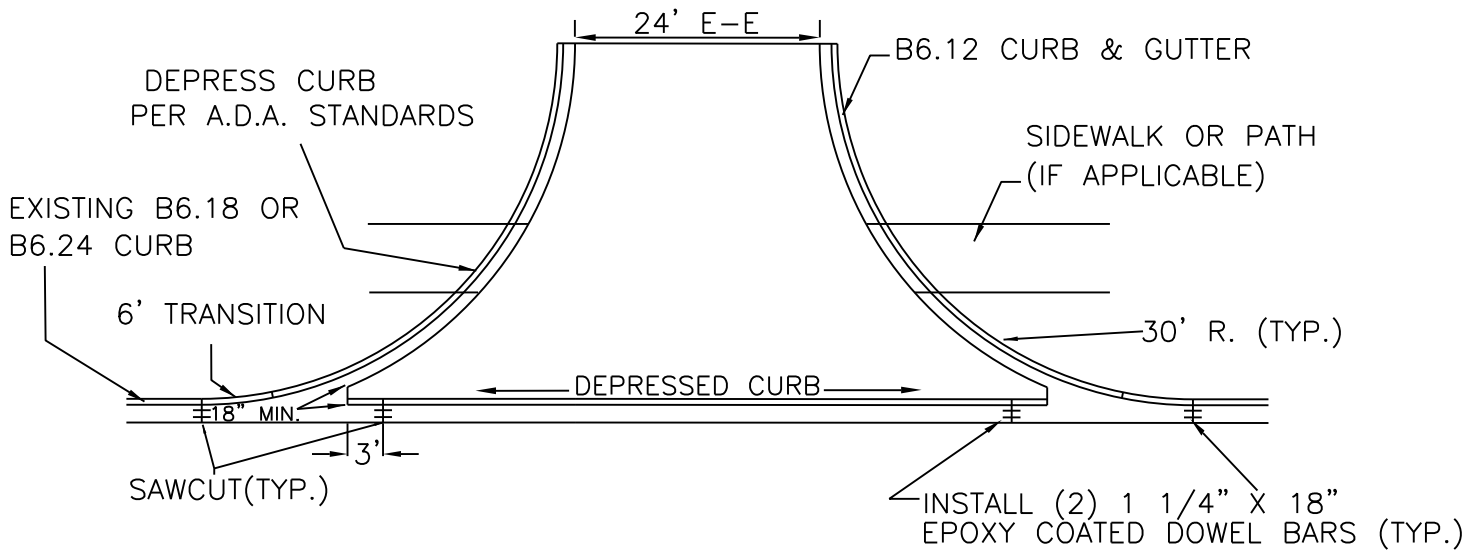

HMA DRIVEWAY

- 1 1/2" HOT MIX ASPHALT SURFACE COURSE N50
- 1 1/2" HOT MIX ASPHALT BINDER COURSE
- 6" HOT MIX ASPHALT BASE COURSE
- 8" AGGREGATE BASE COURSE, TYPE B

INCREASE HMA SURFACE AND BINDER THICKNESS AS NEEDED PER MIXTURE DESIGNS.

PCC DRIVEWAY

- 8" PCC DRIVEWAY PAVEMENT
- 8" AGGREGATE BASE COURSE, TYPE B

COMMERCIAL DRIVEWAY DETAIL

PAVEMENT MARKINGS AND PAVEMENT MARKERS

MATERIALS FOR PAVEMENT MARKINGS:

<u>LOCATION</u>	<u>MATERIAL</u>
ALL MARKINGS ON BITUMINOUS PAVEMENT	THERMOPLASTIC PAVEMENT MARKINGS
ALL MARKINGS ON CONCRETE SURFACES	URETHANE PAVEMENT MARKINGS

INSTALLATION OF PAVEMENT MARKINGS:

<u>LOCATION</u>	<u>TYPE OF MARKING</u>
PAINTED MEDIANS	4" DOUBLE YELLOW; 11" c-c AND 12" YELLOW @ 45°; 30' c-c
BARRIER MEDIANS	4" YELLOW
TURN BAY TAPERS ALONG THRU LANES	6" WHITE, 2' LONG, 6' SPACE (DOTTED WHITE)
START OF TURN BAYS	ARROW AND "ONLY"
END OF TURN BAYS 150'-200' LONG	ADDITIONAL ARROW 10' FROM END
TURN BAYS > 200' LONG	ADDITIONAL "ONLY"
ALL OTHER MARKINGS PER MANUAL OF UNIFORM TRAFFIC CONTROL DEVICES OF ILLINOIS.	

INSTALLATION OF RECESSED REFLECTIVE PAVEMENT MARKERS:

<u>LOCATION</u>	<u>SPACING</u>
DOUBLE YELLOW CENTERLINE, & SKIP-DASH WHITE LANE LINES APPROACH & DEPARTURE FROM INTERSECTIONS & CURVES* * EQUAL TO LENGTH OF TURN BAY, OR 200'	40'
ALONG CURVES OR TAPERS TANGENT SECTIONS	40' 40'
SOLID LANE LINES (TURN BAYS)	40'
END OF PAINTED MEDIANS	3 @ 3' LATERAL

<u>LOCATION</u>	<u>TYPE</u>
DOUBLE YELLOW CENTERLINE	2-WAY YELLOW
PAINTED MEDIANS ≤ 4' WIDE	2-WAY YELLOW
PAINTED MEDIANS >4' WIDE	1-WAY YELLOW
YELLOW LINE ALONG BARRIER MEDIANS ** EXCEPT IN SPECIAL CIRCUMSTANCES	NONE **
SKIP-DASH WHITE LANE LINES, SOLID LANE LINES (TURN BAYS)	
2-WAY, UNDIVIDED ROADWAY	1-WAY WHITE
1-WAY ROADWAY, OR DIVIDED WITH BARRIER MEDIAN	2-WAY WHITE / RED

DUPAGE COUNTY DIVISION OF TRANSPORTATION PRIVATE ENTRANCE DETAIL

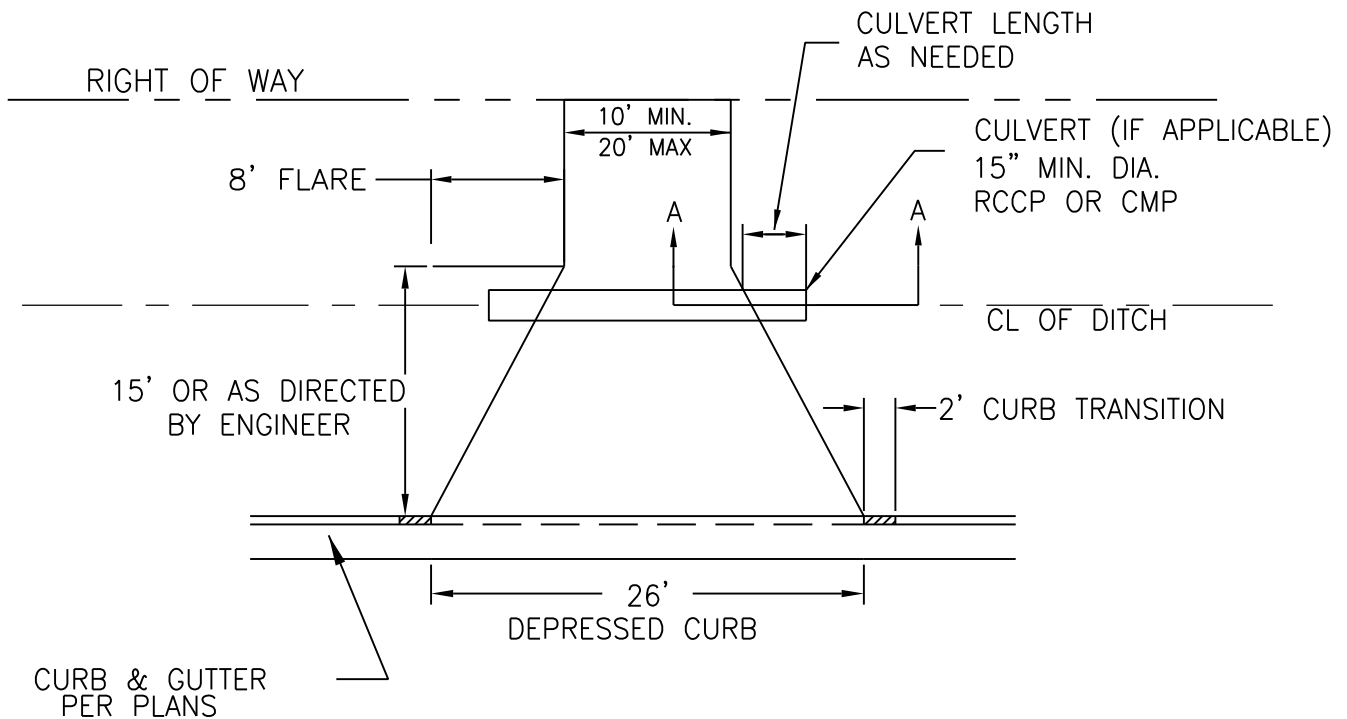

- HMA DRIVEWAY
- 1½" HMA SURFACE COURSE
 - 1½" HMA BINDER COURSE
 - 8" AGGREGATE BASE COURSE, TYPE B

- PCC DRIVEWAY
- 7" PCC DRIVEWAY PAVEMENT
 - 8" AGGREGATE BASE COURSE, TYPE B

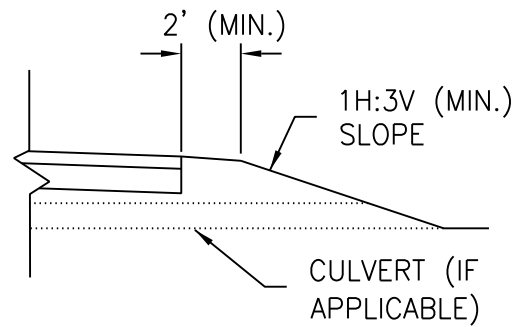

RECESSED PAVEMENT MARKER

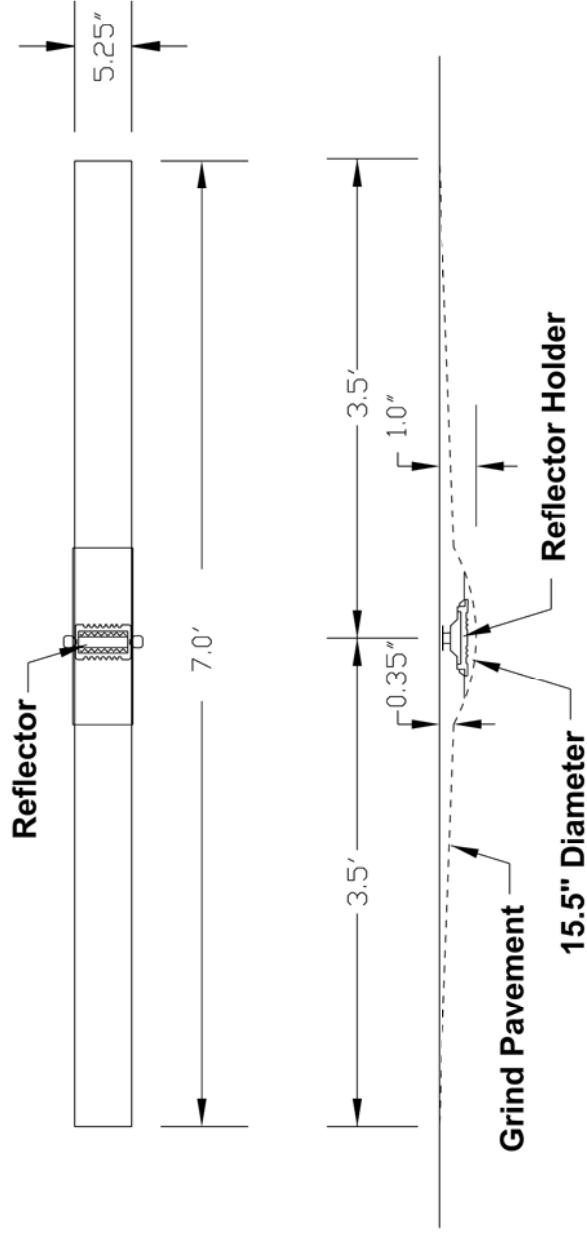
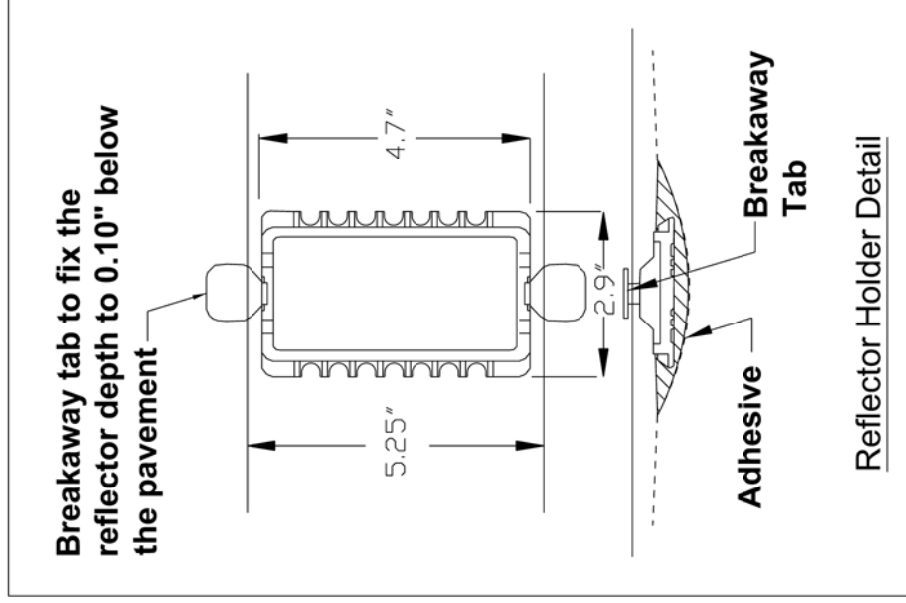

SAG FRAME & LID

Sag Frame and Lid shall be Neenah Foundry Company #R-3305 or equal.

R-3305 Catch Basin Frame and Lid

For behind-the-curb construction.
Heavy-Duty

Total weight 937 Kilograms (425 lbs.)

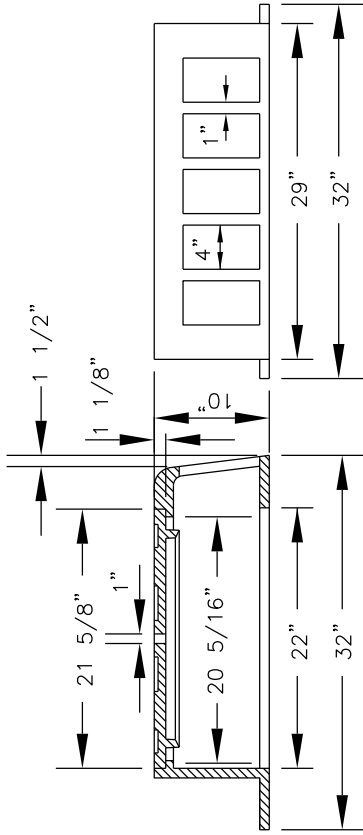

PLAN VIEW

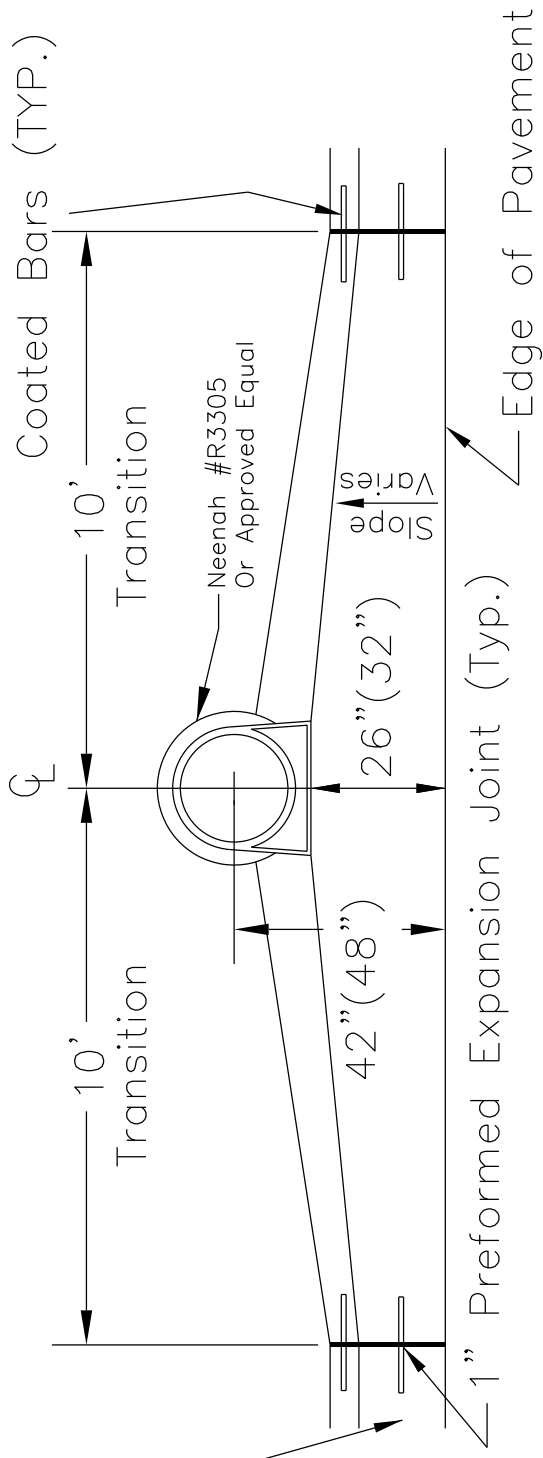

PROFILE VIEW

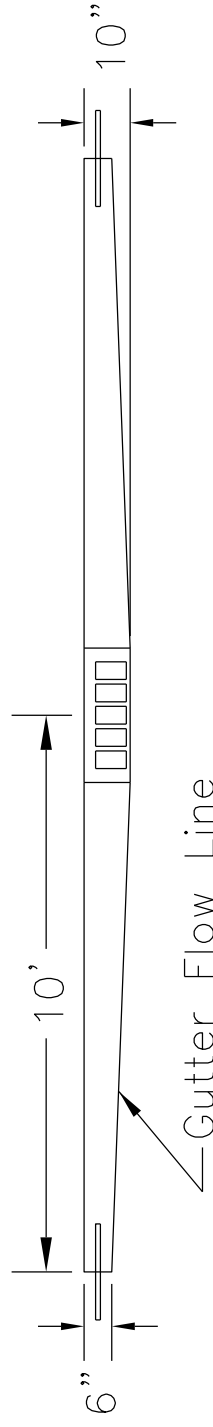

Note: Plan and profile not to scale

TRAFFIC SIGNAL HANDHOLE ADJUSTMENT DETAIL

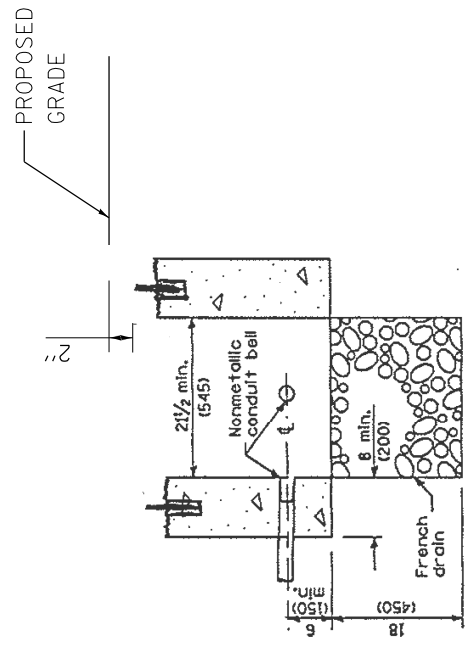
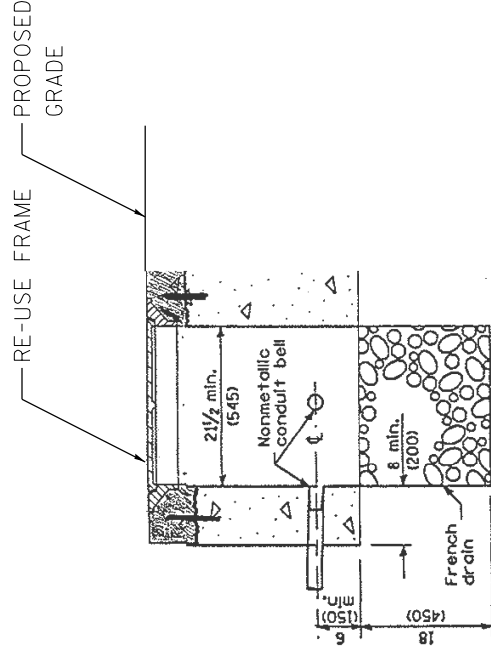
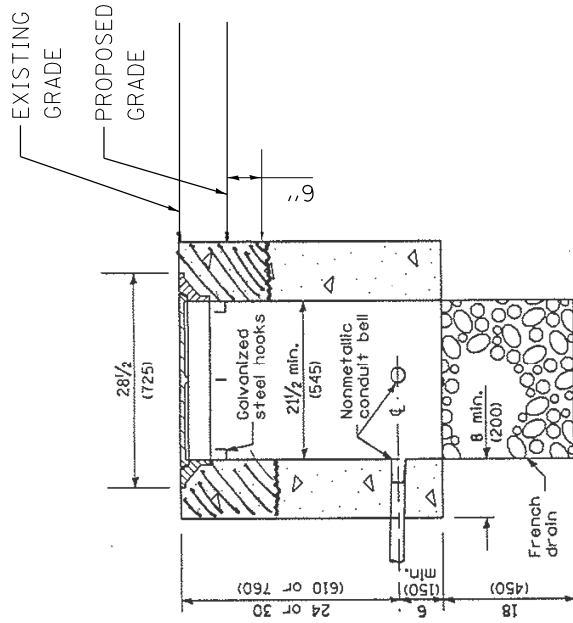

1. BREAK CONCRETE DOWN TO 6" BELOW PROPOSED GRADE SALVAGE FRAME FOR RE-USE

2. DRILL 1/2" DIAMETER HOLES, ONE HOLE CENTERED ON EACH SIDE, 4" DEEP. EPOXY #3 DOWEL, 8" LONG, INTO EACH HOLE.

3. FORM AND POUR CONCRETE TO PROPOSED GRADE, SET SALVAGED FRAME.

TYPICAL TURN BAYS

NOTES:

- SEE MEDIAN DETAILS FOR MEDIAN DEPTH DESIGN, CURB TYPE, AND SIGN POST CUTOUTS.
*ADJUST FOR CURVE SECTION (12:1/10:1)

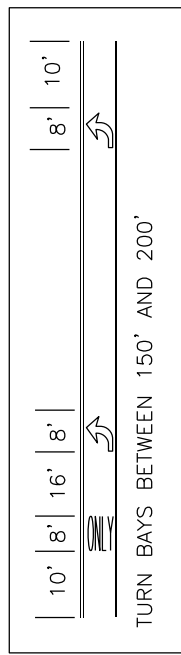
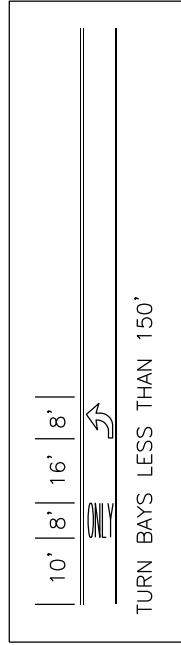
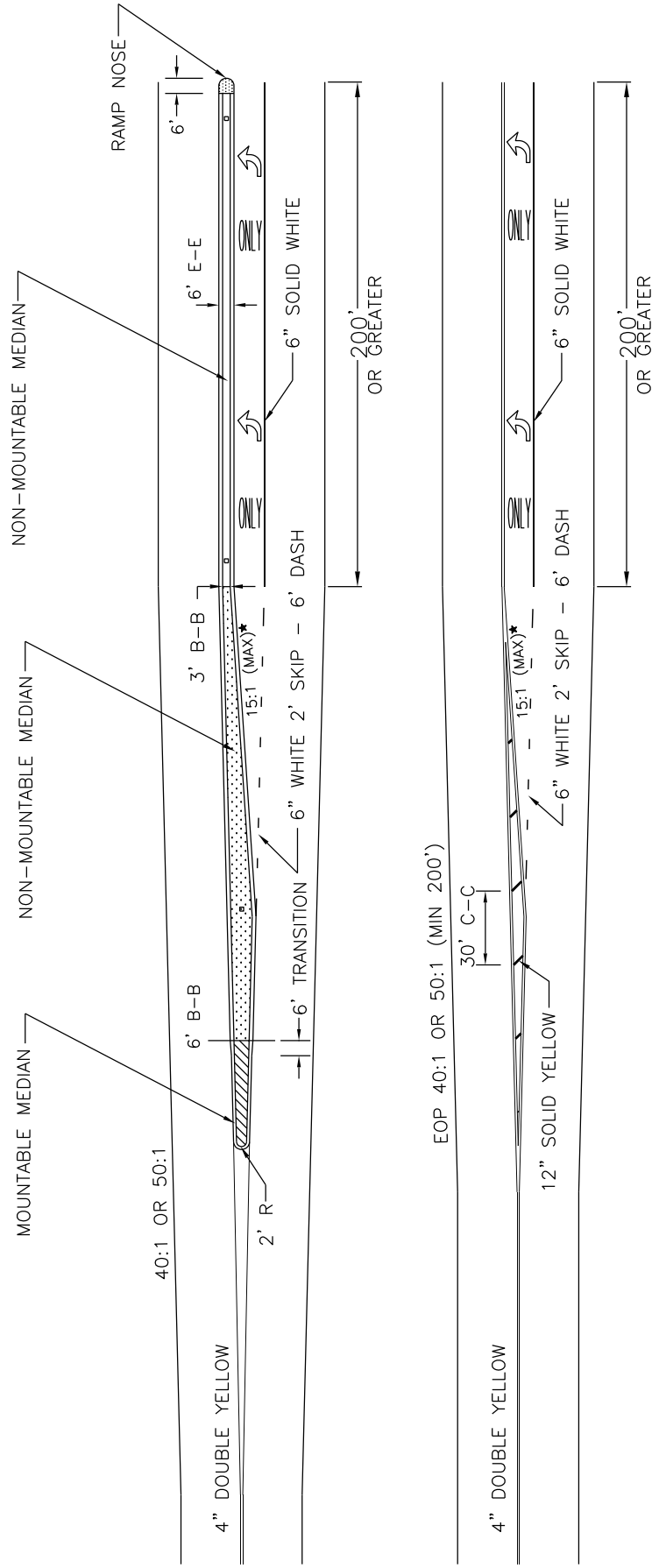

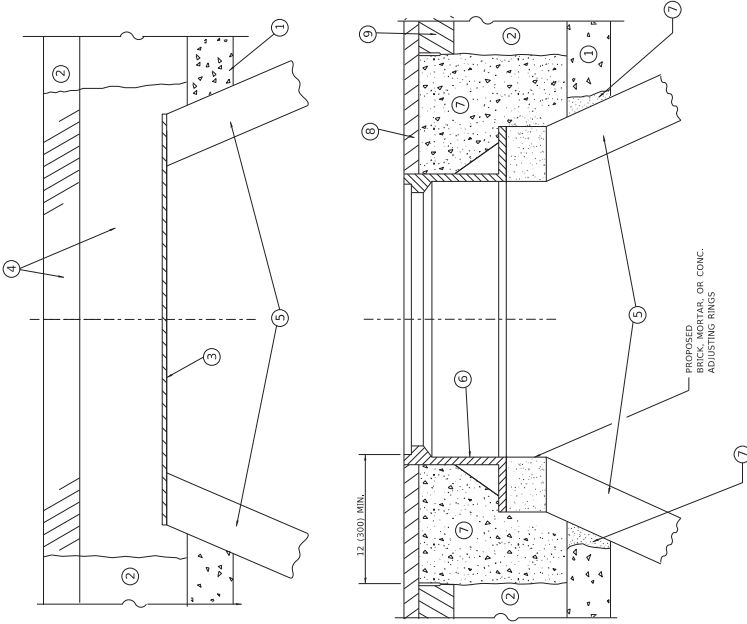

DETAILS FOR FRAMES AND LIDS ADJUSTMENT WITH MILLING

NOTES

- EXISTING BROKEN FRAMES AND LIDS SHALL BE REMOVED AND DISPOSED OF BY THE CONTRACTOR AND SHALL BE REPLACED AS DIRECTED BY THE ENGINEER. REPLACEMENT FRAMES AND LIDS WILL BE PAID FOR IN ACCORDANCE WITH ARTICLE 109.04 OF THE STANDARD SPECIFICATIONS UNLESS A SEPARATE PAY ITEM HAS BEEN PROVIDED.
- IF THE EXISTING LIDS ARE OPEN, THE FRAME WILL BE ADJUSTED TO THE ELEVATION OF THE MILLED PAVEMENT SURFACE PRIOR TO THE MILLING OPERATION. THE FRAME WILL NOT BE REMOVED AND COVERED BY THE METAL PLATE.
- CITY OF CHICAGO CASTINGS ARE THE PROPERTY OF THE CITY AND THE CONTRACTOR SHALL NOTIFY THE CITY FOR REMOVAL AND DISPOSITION OF THE CASTINGS.
- THE METAL PLATE USED TO COVER THE STRUCTURE SHALL REMAIN THE PROPERTY OF THE CONTRACTOR.

CONSTRUCTION PROCEDURES

STAGE 1 (BEFORE PAVEMENT MILLING)

- REMOVE A MINIMUM OF 12 (300) OF THE PAVEMENT FROM AROUND THE STRUCTURE.
- REMOVE THE EXISTING FRAME AND LID FROM THE STRUCTURE.
- COVER THE STRUCTURE OPENING WITH A 36 (900) DIAMETER METAL PLATE.
- BACKFILL WITH CRUSHED STONE AND HMA SURFACE MIX APPROVED BY THE ENGINEER. (MIN. 1 1/2 (40) HMA TO REMAIN AFTER MILLING).

STAGE 2 (AFTER PAVEMENT MILLING)

- REMOVE THE HMA SURFACE MIX AND CRUSHED STONE.
- INSTALL THE FRAME AND LID; ADJUST THE FRAME TO ITS FINAL SURFACE ELEVATION.
- THE SURROUNDING SPACE SHALL BE FILLED WITH CLASS#PP-1 CONCRETE TO THE ELEVATION OF THE SURFACE OF THE EXISTING BASE COURSE OR THE BINDER COURSE.

* UNLESS OTHERWISE SPECIFIED IN THE PLANS.

THE PROCEDURE EXPLAINED ABOVE SHALL CONFORM TO THE APPLICABLE PORTIONS OF SECTIONS 353, 406, 602, AND 603 OF THE STANDARD SPECIFICATIONS EXCEPT THAT THE CONTRACTOR SHALL ADJUST THE STRUCTURES TO THE FINISHED PAVEMENT ELEVATION NO MORE THAN 5 CALENDAR DAYS PRIOR TO PLACEMENT OF THE FINAL LIFT OF SURFACE UNLESS APPROVED BY THE ENGINEER.*

LEGEND

- SUB-BASE GRANULAR MATERIAL
- EXISTING PAVEMENT
- 36 (900) DIAMETER METAL PLATE
- PROPOSED CRUSHED STONE AND HMA SURFACE MIX
- EXISTING STRUCTURE
- FRAME AND LID (SEE NOTES)
- CLASS#PP-1 CONCRETE
- PROPOSED HMA SURFACE COURSE
- PROPOSED HMA BINDER COURSE

LOCATION OF STRUCTURES

THE CONTRACTOR WILL BE REQUIRED TO KEEP A RECORD OF THE LOCATIONS OF THE BURIED STRUCTURES ACCORDING TO THE STATION AND DISTANCE LEFT OR RIGHT OF THE CENTERLINE OF PAYMENT. UPON COMPLETION OF THE WORK, THE CONTRACTOR WILL DELIVER THE RECORD TO THE ENGINEER.

BASIS OF PAYMENT

- REMOVING FRAMES AND LIDS ON DRAINAGE AND UTILITY STRUCTURES IN THE PAVEMENT PRIOR TO MILLING, AND ADJUSTING TO FINAL GRADE PRIOR TO PLACING THE SURFACE COURSE, WILL BE PAID FOR AT THE CONTRACT UNIT PRICE EACH FOR "FRAMES AND LIDS TO BE ADJUSTED (SPECIAL)".
- THIS WORK WILL NOT BE PAID FOR WHEN DRAINAGE AND UTILITY STRUCTURES ARE SPECIFIED FOR PAYMENT AS STRUCTURE RECONSTRUCTION.
- NEW FRAMES AND LIDS, WHEN SPECIFIED, WILL BE PAID FOR SEPARATELY.
- WHEN STRUCTURES ARE TO BE ADJUSTED OR RECONSTRUCTED, THE LOWERING AND RAISING OF THE FRAMES AND LIDS WILL NOT BE PAID FOR SEPARATELY BUT WILL BE INCLUDED IN THE COST OF THE CORRESPONDING PAY ITEM.

SCALE: NONE		SHEET 1 OF 1 SHEETS		STA. TO STA.	ILLINOIS	FED. AID PROJECT
STATE OF ILLINOIS DEPARTMENT OF TRANSPORTATION				FRAMES AND LIDS ADJUSTMENT WITH MILLING		
DESIGNED - R. SHIH		DRAWN -		SECTION		
REVISED - R. BORO 01-01-07		REVISED - R. BORO 03-09-11		FILE		
REVISED - R. BORO 12-06-11		REVISED - K. SMITH 02-01-22		BD600-03 (RD-08)		
DESIGNED - R. SHIH		DRAWN -		COUNTY		
REVISED - R. BORO 01-01-07		REVISED - R. BORO 03-09-11		SHEETS		
REVISED - R. BORO 12-06-11		REVISED - K. SMITH 02-01-22		SHEETS		
DESIGNED - R. SHIH		DRAWN -		CONTRACT NO.		
REVISED - R. BORO 01-01-07		REVISED - R. BORO 03-09-11		SHEETS		
REVISED - R. BORO 12-06-11		REVISED - K. SMITH 02-01-22		SHEETS		
DESIGNED - R. SHIH		DRAWN -		CONTRACT NO.		
REVISED - R. BORO 01-01-07		REVISED - R. BORO 03-09-11		SHEETS		
REVISED - R. BORO 12-06-11		REVISED - K. SMITH 02-01-22		SHEETS		

ALL DIMENSIONS ARE IN INCHES (MILLIMETERS) UNLESS OTHERWISE SHOWN

SCALE: NONE		SHEET 1 OF 1 SHEETS		STA. TO STA.	ILLINOIS	FED. AID PROJECT
STATE OF ILLINOIS DEPARTMENT OF TRANSPORTATION				FRAMES AND LIDS ADJUSTMENT WITH MILLING		
DESIGNED - R. SHIH		DRAWN -		SECTION		
REVISED - R. BORO 01-01-07		REVISED - R. BORO 03-09-11		FILE		
REVISED - R. BORO 12-06-11		REVISED - K. SMITH 02-01-22		BD600-03 (RD-08)		
DESIGNED - R. SHIH		DRAWN -		COUNTY		
REVISED - R. BORO 01-01-07		REVISED - R. BORO 03-09-11		SHEETS		
REVISED - R. BORO 12-06-11		REVISED - K. SMITH 02-01-22		SHEETS		
DESIGNED - R. SHIH		DRAWN -		CONTRACT NO.		
REVISED - R. BORO 01-01-07		REVISED - R. BORO 03-09-11		SHEETS		
REVISED - R. BORO 12-06-11		REVISED - K. SMITH 02-01-22		SHEETS		

LOOPS NEXT TO SHOULDERS

REMOVE A PAVED OR UNPAVED SHOULDER PER-APPROACH. NOTE WHICH SHOULD EQUAL 3' (900 mm) X WIDTH OF PAVED SHOULDER.

PAVED OR NON-PAVED SHOULDER

1' (300 mm)

5' (1500 mm)

10' (3000 mm)

1.8' (600 mm)

1'-0.25' (305 mm) UNIT DUCT-TRENCHED TO E.P.

LEFT TURN LANES WITH MEDIANS
VOLUME DENSITY ("FAR OUT" DETECTION) ON SAME APPROACH (PROTECTED / PERMITTED LEFT TURN PHASING)

HANDHOLE LOCATION MAY VARY BASED ON METRICS AND DESIGN OF TRAFFIC SIGNALS. USE DUTY CYCLES TO BE MOUNTABLE. REFER TO STANDARD FITS IN MEDIAN.

1900 mm

12'

11.8'

6'

UNIT DUCT (1.8' (600 mm)) PERPENDICULAR TO MEDIAN (TYP.)

STRAIGHT SAW CUTS PERPENDICULAR TO MEDIAN (TYP.)

RESERVED (1.8' (600 mm))

* = 600 mm

LEFT TURN LANES WITHOUT MEDIANS
VOLUME DENSITY ("FAR OUT" DETECTION) ON SAME APPROACH (PROTECTED / PERMITTED LEFT TURN PHASING)

1900 mm

12'

11.8'

6'

STRAIGHT SAW CUT TO HEAVY DUTY HANDHOLE (TYP.). PLACE HEAVY DUTY HANDHOLE IN CENTER OF SECOND LOOP AS SHOWN.

* = 600 mm

ARTERIAL-VOLUME DENSITY ("FAR OUT" DETECTION)
CROSS STREET-VOLUME DENSITY ("FAR OUT" DETECTION)

UNIT DUCT IS TO BE SHOWN ON PLAN SHEETS BUT SHALL NOT BE INCLUDED IN THE PAY ITEMS.

NOTE: DUAL LEFT TURNS NOT SHOWN REFER TO PLAN SHEET FOR DETECTOR LOOP REPLACEMENT

* = 600 mm

ARTERIAL-VOLUME DENSITY ("UP/TIGHT" DETECTION)
CROSS STREET-NON VOLUME DENSITY ("UP/TIGHT" DETECTION)

UNIT DUCT IS TO BE SHOWN ON PLAN SHEETS BUT SHALL NOT BE INCLUDED IN THE PAY ITEMS.

NOTE: DUAL LEFT TURNS NOT SHOWN REFER TO PLAN SHEET FOR DETECTOR LOOP REPLACEMENT

* = 600 mm

VEHICLES LOOP DETECTORS

- ALL LEAD IN CABLE SHALL BE TWO CONDUCTOR NO. 14 TWISTED, SHIELDED.
- EACH DETECTOR LOOP SHALL HAVE ITS OWN SAW CUT FROM THE LOOP TO THE EDGE OF PAVEMENT OR TO A HANDHOLE IN THE PAVEMENT.
- EACH DETECTOR LOOP SHALL HAVE ITS OWN ONE INCH (25 mm) UNIT DUCT BETWEEN THE EDGE OF PAVEMENT AND THE FIRST HANDHOLE OR JUNCTION BOX. EACH UNIT DUCT RUN SHALL BE SHOWN ON THE PLANS BY THE DESIGNER, BUT SHALL NOT BE PAID FOR SEPARATELY. THIS ITEM IS INCIDENTAL TO THE PAY ITEM FOR DETECTOR LOOPS.
- ONE DIMENSION OF ALL DETECTOR LOOPS SHALL BE SIX FEET (1.8 m)
- EACH LANE OF NON-LOCKING, PRESENCE DETECTION AND EACH LANE OF A DOUBLE LEFT TURN LANE REQUIRES A SEPARATE INDUCTIVE LOOP DETECTOR AND LEAD IN CABLE.
- WHEN NON-LOCKING, PRESENCE DETECTION IS USED, MORE THAN ONE LOOP PER LANE IS REQUIRED BEHIND THE STOP BAR (i.e., 1-1/2, 1-3/4, 2).
- WHEN SYSTEM LOOPS ARE REQUIRED ON AN APPROACH OF AN INTERSECTION, THE LOOPS USED FOR VOLUME DENSITY AND DETECTION TIMING SHALL BE OF THE SAME TYPE. PROVIDE A SEPARATE TWO CONDUCTOR NO. 14 TWISTED SHIELDED CABLE AND A SEPARATE INDUCTIVE LOOP DETECTOR WHEN NEW CONTROLLERS ARE UTILIZED. THE DESIGNER SHALL LABEL THESE TYPES OF LOOPS AS "INTERSECTION AND SAMPLING (SYSTEM DETECTORS)" ON THE SIGNAL LAYOUT, THE INTERCONNECT PLAN AND THE SYSTEM CABLE PLAN. WHEN AN EXISTING CONTROLLER IS UTILIZED FOR THIS TYPE OF DETECTION, THE PAY ITEM "INDUCTIVE LOOP DETECTOR WITH SYSTEM OUTPUT" SHOULD BE USED.

PLACEMENT OF DETECTORS

THE FOLLOWING FIGURES REPRESENT THE MOST COMMON DETECTOR LOOP LOCATIONS AND SIZES; ADJUSTMENTS WILL BE NECESSARY FOR SPECIFIC GEOMETRIC CONSIDERATIONS.

LOCATIONS AND DIMENSIONS OF DETECTOR LOOPS ARE REQUIRED ON ALL SIGNAL LAYOUT PLAN SHEETS.

"FAR OUT" DETECTION REFERS TO LOCKING, PRESENCE TYPE DETECTION LOCATED IN THRU LANES, RIGHT TURN LANES, AND RIGHT TURN LANE TAPER AREAS (IF APPLICABLE), USUALLY 250' (75 m) IN ADVANCE OF STOP BARS. "UP/TIGHT" DETECTION REFERS TO NON-LOCKING PRESENCE TYPE DETECTION LOCATED IN THRU LANES AND 10'-15' (3.0-4.5 m) BEHIND THE CROSSING STREET'S EDGE OF PAVEMENT EXTENDED.

NOTE:

ALL DETAILS AND NOTES SHOWN ARE FROM THE I.D.O.T. DISTRICT 1 TRAFFIC SIGNAL DESIGN GUIDELINES DATED JANUARY 1995

THIS DRAWING HAS BEEN PREPARED TO ASSIST THE RESIDENT ENGINEER FOR ALL ROADWAY RESURFACING OR S.M.A.R.T. PROJECTS WHERE THE DIMENSIONS ARE NOT SHOWN ON THE PLANS AND THE FINAL LOCATIONS FOR CROSSWALKS OR STOP BARS ARE NOT DETERMINED.

FILE NAME	DESIGNED	REVISION	DISTRICT 1 - DETECTOR LOOP INSTALLATION	SHEET NO.	SECTION	COUNTY	PROJECT NO.
USER NAME = gregkoebert	REVISION	REVISION	DETAILS FOR ROADWAY RESURFACING	15-07	15-07	ILLINOIS	ILLINOIS DIST. NO. 1
PLOT SCALE = 500000 / IN.	DRAWN	REVISION	STATE OF ILLINOIS	SHEET NO. 1 OF 1	STA.	TO STA.	CONTRACT NO.
PLOT DATE = 1/4/2008	CHECKED	REVISION	DEPARTMENT OF TRANSPORTATION	SCALE NONE			FED. ROAD DIST. NO. 1
	DATE	REVISION					

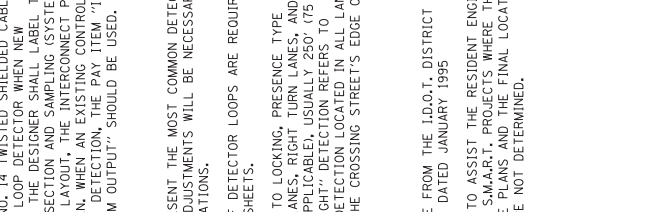
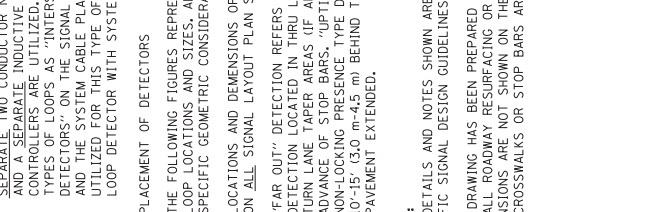
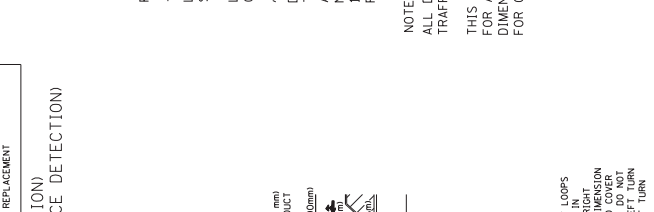
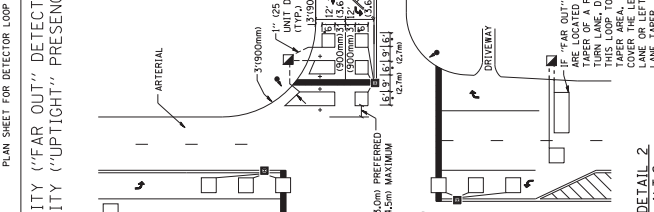
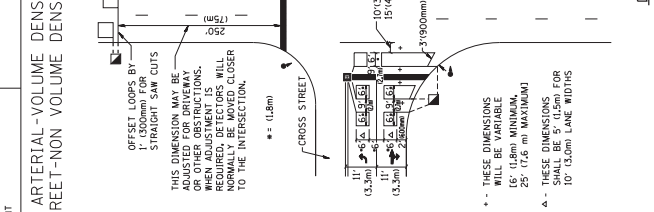
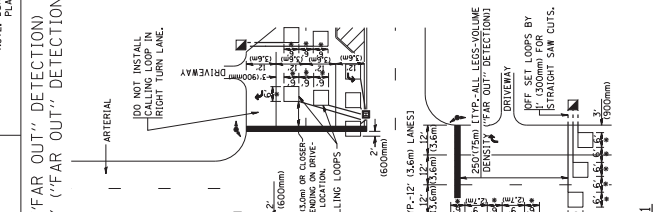
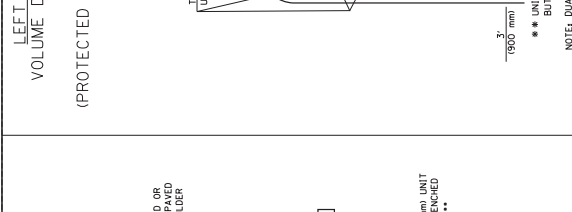
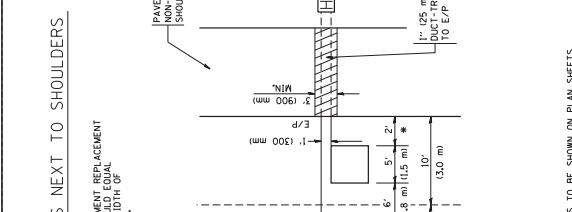

FILE NAME	DESIGNED	REVISION	DISTRICT 1 - DETECTOR LOOP INSTALLATION	SHEET NO.	SECTION	COUNTY	PROJECT NO.
USER NAME = gregkoebert	REVISION	REVISION	DETAILS FOR ROADWAY RESURFACING	15-07	15-07	ILLINOIS	ILLINOIS DIST. NO. 1
PLOT SCALE = 500000 / IN.	DRAWN	REVISION	STATE OF ILLINOIS	SHEET NO. 1 OF 1	STA.	TO STA.	CONTRACT NO.
PLOT DATE = 1/4/2008	CHECKED	REVISION	DEPARTMENT OF TRANSPORTATION	SCALE NONE			FED. ROAD DIST. NO. 1
	DATE	REVISION					